

# Perdue

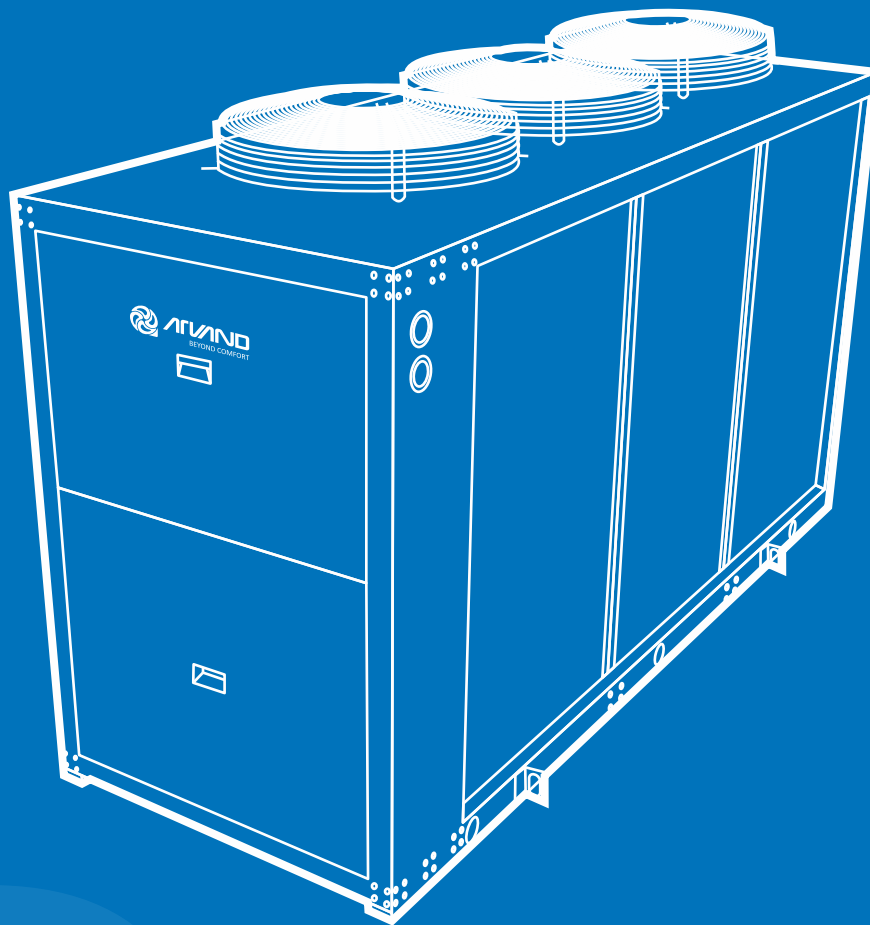

Air Cooled Scroll Chiller

## PERDUE SERIES



6	Introduction
7	Nomenclature
8	Features and Advantages
9	Application Considerations
10	Components
11	Options & Accessories
12	Physical and Technical Data
16	Dimensions and Clearances
20	Performance Data
30	Hydraulic Data
32	Operating Limits
33	Electrical Data
35	Control
36	Engineering Guide Specifications
37	Selecting Procedure
39	Appendix



# AIR COOLED SCROLL CHILLER PERDUE SERIES

چیلر هوا خنک اسکرال

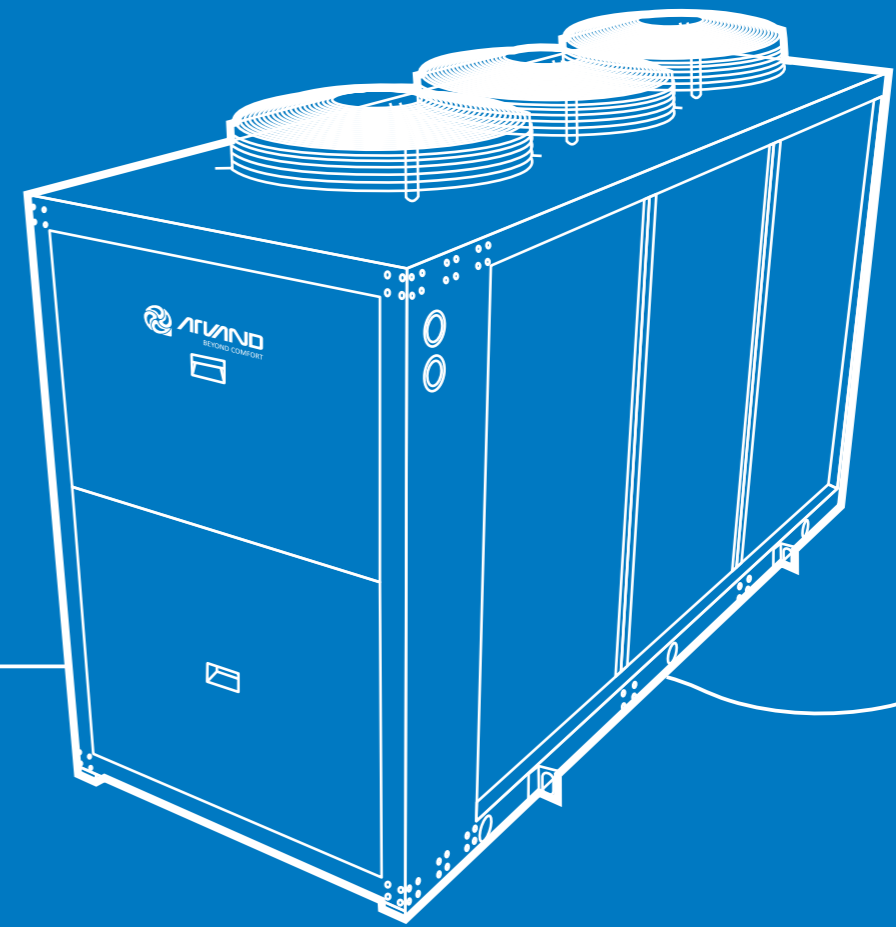

## INTRODUCTION

Arvand ACS chillers are manufactured to the highest design and construction standards to ensure high performance, reliability and adaptability to all types of air conditioning installations. Units are compact and highly configurable, built to fit different types of plants so to meet the needs of highly qualified engineers.

Units are water chillers condensed in air with axial fans suitable for outdoor installation, The structure and panels are robust, made of galvanized and painted steel, all fasteners are made of stainless steel or galvanized steel, the frame containing the electrical equipment and all the components exposed to weather have a minimum IP54 degree of protection. This series is composed of 40 models with nominal cooling capacity from 50 to 410 kW.

units produce cold water from 5 to 10°C and as standard they are equipped with continuous adjustment of axial fans rotating speed in order to allow the units to operate with low outdoor temperature in cooling mode as well as to reduce noise emissions.

All the units are equipped with 2 or 4 scroll compressors arranged in pairs (tandem) on 1 or 2 circuit operating with environmentally friendly R410A-R407C refrigerant. The high efficient DX evaporator is shell and tube type heat exchanger completely insulated. The Condenser coil heat exchanger made of V-Waffle aluminum fins and copper tubes, axial fans with profiled blades to contain noise and with thermal protection built-in, electrical control panel equipped with control system to manage the main functions.

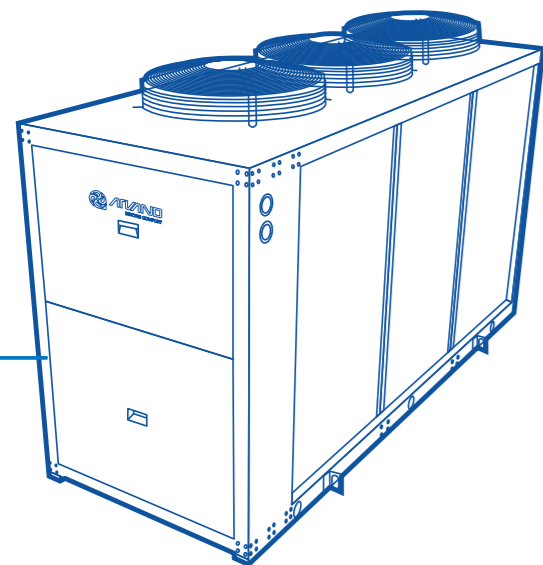

## NOMENCLATURE

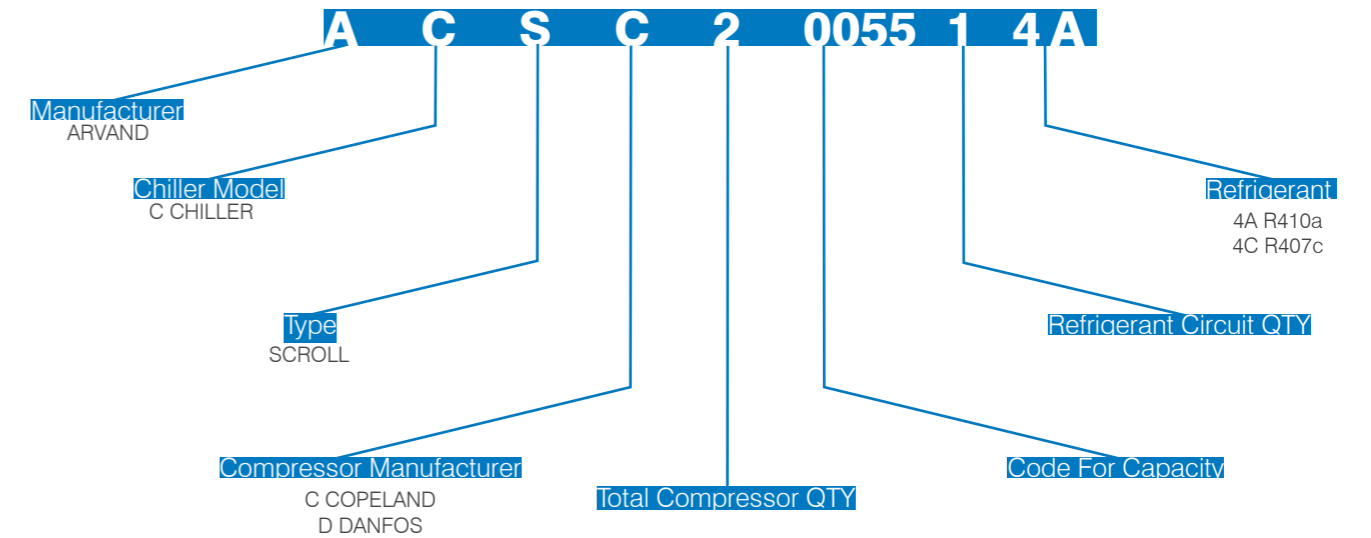

- Operating and charging with R407C and R410A refrigerants.
- The compact size of the ACS series chillers makes them easy to install.
- Scroll compressor with 100 % volumetric efficiency.
- Direct-drive, low-speed scroll compressors with fewer moving parts provide maximum efficiency, high reliability, and low maintenance requirements. Suction gas-cooled motor stays at a uniformly low temperature for long motor life.
- Significantly lower noise levels than other scroll compressor chillers.
- To maximize noise reduction, all compressors are enclosed inside a silencer box.
- Substantial condenser fins, that do not require additional coating in non-corrosive environments, contribute to the highest reliability standards for air-cooled chillers in the industry.
- Units Consisting of 2 pressure gauges for each circuit that display the pressure values of the refrigerating fluid on the compressor suction and discharge sides.
- One switch on compressors discharge line preserve operation not allowing pressure to rise up than a specified nonadjustable value.
- The unit starts and operates from 10°C to 52°C ambient temperature.
- The evaporator is covered with factory-installed (12-19 mm) or equal (k=0.28) insulation in EPDM or NBR.
- Performance tests are available to certify chiller performance before shipment.
- Controlling the phase-sequence of mains.
- Interface module for Mod BUS protocols

Accessing the unit

The access to the unit must be granted exclusively to qualified personnel trained to operate on this type of units and provided with the necessary protection equipment.

Important

Certain application constraints should be considered when sizing, selecting and installing ACS air-cooled chillers. Unit and system reliability are often dependent upon proper and complete compliance with these considerations.

Unit Sizing

Unit capacities are listed in the performance data section. Intentionally over sizing a unit to assure adequate capacity is not recommended. Erratic system operation and excessive compressor cycling are often a direct result of an oversized chiller. In addition, an oversized unit is usually more expensive to purchase, install, and operate. If over sizing is desired, consider using multiple units.

Water Treatment

However, in designing ACS chillers the effect of fouling thermal resistance is considered but dirt, scale, products of corrosion and other foreign material will adversely affect heat transfer between the water and system components. Polluted chilled water in system gets more pressure drop than pure water and consequently, reduce water flow. Neither salt nor brackish water is recommended for use in ACS air-cooled chillers. Use of either will lead to a shortened life to an indeterminable degree.

Effect of Altitude

The performance data of chillers which tabled, are chillers operation in sea level. Increasing the altitude reduces the density of the air and thereby reduce the condenser capacity, which lead to decrease unit capacity and efficiency.

Leaving Chilled Water Temperature

The chillers are rated as standard base on 12- 7°C entering - leaving water temperature and 35°C ambient temperature. The performance data of the units are presented for customers based on 5 to 10°C range of leaving water temperatures and 30 to 52°C ambient temperatures. When the outlet water temperature decreases below 5°C, antifreeze will be activated and compressor(s) will be stopped. Ethylene glycol is recommended to prevent freezing, if the customer needs are below the range of performance data table.

Water flow rate

Maximum and minimum water flow rates are determiner of minimum and maximum allowable temperature drop in evaporator, if the flow rate or temperature drop does not meet customer demand, a mixing loop is required like what is showed in the following picture.

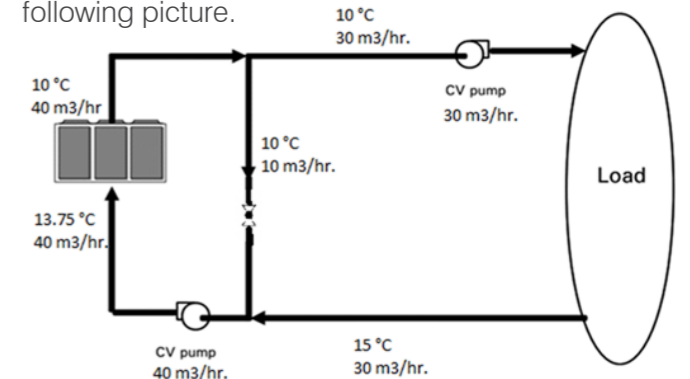

Figure 1 flow rate out of range

Leaving water temperature

If the LWT requirement is greater than 15 C, a mixing loop is required like what is showed in the following picture.

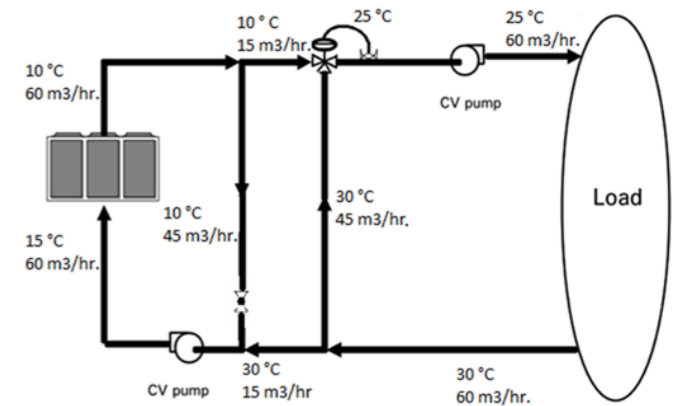

Figure 2 leaving water temperature out of range

Chilled Liquid Piping

All building water piping must be flushed prior to making the final connections to the chiller. To reduce heat loss and prevent condensation, insulation should be installed. Expansion tanks are also usually required so that chilled water volume changes can be accommodated.

The chilled liquid piping system must be laid out so that the circulating pump discharges directly into the cooler. The inlet and outlet chilled liquid connections are given in Technical Data. It is recommended to drain the circulation water circuit in out of operating season. If not able to drain, you should add the ethylene glycol with proper concentration to hydraulic circuit to protect against freeze up during low ambient periods.

### Typical Unit Installation

Although these units are very quiet operation but It is recommended to install unit away from sound sensitive areas of the building or away windows. When physically isolating the unit from structures, it is a good idea to not use rigid supports, and to eliminate any metal-to-metal or hard material contact, when possible. This includes replacing spring or metal weave isolation with elastomeric isolators.

### Pollution

The unit contains refrigerant gas and lubricating oil. During discarding such fluids must be recovered and eliminated according to the regulations in force in the country where the unit is installed. The unit must not be abandoned during discarding.

### Foundation

Mount the unit on a level concrete foundation. Floors must be strong enough to support the unit operating weight. If necessary, use structural supports to transfer the weight of the unit to the nearest beams.

## Components

### Compressor

The unit is equipped with two or more hermetic, direct-drive, 2900 rpm 50 Hz suction gas-cooled scroll compressors. The simple design has only three major moving parts and a completely enclosed compression chamber which leads to increased efficiency Compressor. Overload protection is included. Centrifugal oil pump, oil level sight glass and oil charging valve are included. Each compressor will have crankcase heaters installed and properly sized to minimize the amount of liquid refrigerant present in the oil sump during off cycles.

### Comprehensive Acoustic Package

Includes acoustical treatment for compressors.

### REFRIGERANT CIRCUIT

Each compressor operates on an independent copper tubing refrigerant circuit. Refrigerant circuit components include the following, one each per circuit:

- Electronic expansion valve.
- Liquid-line solenoid valve.
- Sight glass with moisture indicator.
- Shell and core filter-drier with high absorption removable core and charging port.
- Service valve on liquid line, gas discharge and suction line.
- Safety valve on high-pressure side.
- High pressure safety switch with manual reset.
- Refrigerant circuit with copper tubing with anticondensation insulation of the suction line.
- Plastic capillary hoses for pressure sensors connection.

The suction line is covered in closed-cell insulation. Discharge and suction lines provided with a manual compressor shutoff service valve

### Condenser and Fans

The condenser constructed with seamless inner-grooved copper tubes expanded into die-formed aluminum V-Waffle fins in staggered configuration. The design working pressure is 31 bar (450 psi) for R407C models and 42 bar (610 psi) for R410A models.

Direct drive vertical discharge condenser fans are dynamically balanced. Three-phase condenser fan motors with permanently lubricated ball bearings and internal thermal overload protection are provided.

### Protective grilles

To protect condenser coil, a painted perforated steel or Meshed Wired Guard are provided in all chillers condenser outer surfaces

### Evaporator

The evaporator is of the dry expansion shell and tube type with one or two independent refrigerant circuits and a single water circuit. The refrigerant flows inside the inner grooved copper tubes which increase exchange efficiency, while the water, which is oriented by baffles, flows over the outside of the tubes. It is insulated with 12 to 15 mm thick closed cell EPDM or NBR foam material.

Removable heads on the cooler allow access to internally-enhanced, seamless, copper tubes. Water vent and drain connections included.

### Capacity Modulation

The 50-180 kW units have single refrigerant circuits and 160 -410 kW units have dual refrigerant circuits. Each refrigerant circuit has Copeland or Danfoss scroll compressors coupled in parallel with a passive oil management system. A passive oil management system maintains proper oil levels within compressors and has no moving parts. Capacity modulation is achieved by turning compressors on and off.

### ELECTRICAL PANEL

The electrical panel is located in a metal case arranged outside the unit. The metal case has an IP54 protection rating and for force air ventilation a fan has located in the bottom of section and a filter in the top. installation, complete with:

- Main switch.
- MCCB circuit breaker for each Compressor, fan and water pump (if scheduled).
- Contactors for each load.
- Transformer for auxiliary circuit and Programable Controller supply.
- Power supply: 400/3/50.

### Unit Controls

The microprocessor-based control panel is factory-installed and factory-tested. The control system is powered by a pre-wired control power supply, and will turn on and off compressors to meet the load. Microprocessor-based chilled water reset based on supply water is standard.

The panel includes machine protection for the following conditions:

- Low evaporator refrigerant temperature and pressure
- High condenser refrigerant pressure
- Critical sensor or detection circuit faults
- High compressor discharge temperature (with low temp evaporator)
- Lost communication between modules
- Electrical distribution faults: phase loss, phase reversal or over temperature protection
- External and local emergency stop
- Loss of evaporator water flow

## Options & Accessories

### Flow switch

Paddle flow switch on the water circuit to avoid the risk of freezing if the water flow is shut off for some reason.

### Compressor

Danfoss or Copeland are same as performance and quality both compressors are available for all models.

### Condenser Coil – Anti Corrosion Coating

Our standard coils are constructed with Aluminum fins (This is not recommended for units in areas where they may be exposed to acid rain). In humid area its recommended to use Hydrophilic Aluminum Coating. In Harsh and Corrosive environments like oil Field and coast area application, copper fin with Heresite or Alcotherm Bly-Gold or Thermo Guard coating uses to protect air cooled heat exchangers.

### Low Ambient Kit

Units will operate to 10 °C ambient temperature. This accessory include liquid receiver and heat exchanger accumulator to permit chiller operation down to -15 °C.

### Low Noise Fan

Incorporate low noise fans to reduce unit sound level.

### Pump Package

Pump package include:

One or two pumps, expansion vessels, drainage valves, shut-off valves at entering and leaving connections.

The pump package is single point power integrated into the chiller unit power with a separate factory wired control panel. The control of the pump is integrated into the chiller controller.

The cold parts of the pump package will also be insulated.

### Buffer Tank (only available with pump package)

The water tank is factory-installed for easy installation at the building site. The tank is engineered for continuous flow and is fully insulated as standard and is designed with freeze protection. The purpose of the tank is to increase the chilled water circuit inertia, which is necessary with short water loops. A high circuit inertia reduces the compressor's cycling to increase the compressor life span and allow for more precise water temperature accuracy. It also saves energy as compared to hot gas bypass.

### Vibration Isolators

Level adjusting, spring type 1" (25.4mm) or seismic deflection or neoprene pad isolators for mounting under unit base rails.

R410A, 1 Circuit, 2-Compressor Units

Refrigerant R410A														
Unit ACSC20.....14A	055	060	065	075	090	105	115	130	145	165	185	205		
<b>Performance data</b>														
Cooling Capacity	kW	53	60	65	73	92	103	116	128	143	165	187	207	
Total Power Input	kW	16	19	21	23	27	31	34	38	42	50	57	66	
EER	kW/kW	3.25	3.19	3.11	3.19	3.37	3.33	3.46	3.34	3.37	3.30	3.28	3.16	
Energy Class	-	A	A	A	A	AA	AA	AA	AA	AA	A	A	A	
<b>General Unit Data</b>														
Number of Independent Refrigerant Circuits	-	1	1	1	1	1	1	1	1	1	1	1	1	
Refrigerant Charge	kg	14	14	14	17	23	23	31	31	32	35	35	36	
Oil Charge	Liters	6.5 / 0	6.5 / 0	6.5 / 0	6.5 / 0	6.5 / 0	7.92 / 0	9.34 / 0	9.34 / 0	9.34 / 0	10.97 / 0	12.6 / 0	12.6 / 0	
Compressors, Scroll Qty per Chiller	-	2	2	2	2	2	2	2	2	2	2	2	2	
<b>Condensers, High Efficiency Fin/Tube with Integral Subcooler</b>														
Number of Rows		3	3	3	4	4	4	4	4	4	4	4	4	
Fins per inch		12	12	12	12	12	12	12	12	12	12	12	12	
<b>Condenser Fans</b>														
Type		Axial												
Number		3	3	3	3	2	2	2	2	3	3	4	4	
Fan Motor	kW	1.1	1.1	1.1	1.1	1.9	1.9	1.9	1.9	1.9	1.9	1.9	1.9	
Fan & Motor Speed	RPM	900	900	900	900	900	900	900	900	900	900	900	900	
Fan Diameter	mm	710	710	710	710	800	800	800	800	800	800	800	800	
<b>Evaporator, Direct Expansion</b>														
Type		Shell & Tube Heat Exchanger												
Water Flow Rate	l/min	151.7	171.7	185.0	210.0	263.3	295.0	333.3	365.0	408.3	471.7	535.0	591.7	
Cooler pressure drop	kpa	10	13	15	18	23	27	34	41	24	31	39	47	
Maximum Water Side Pressure	Bar	10	10	10	10	10	10	10	10	10	10	10	10	
Maximum Refrigerant Side Pressure	Bar	27	27	27	27	27	27	27	27	27	27	27	27	
Maximum Chilled Water Flow Rate	l/min	182.0	206.0	222.0	252.0	316.0	354.0	400.0	438.0	490.0	566.0	642.0	710.0	
Minimum Chilled Water Flow Rate	l/min	106.2	120.2	129.5	147.0	184.3	206.5	233.3	255.5	285.8	330.2	374.5	414.2	
Nominal Water Connections size	Inches	2			3				4					
<b>Electrical</b>														
Power Supply	V/Ph/Hz	380~420/3/50												
<b>Dimension &amp; Weight</b>														
Length	mm	3050	3050	3050	3050	3605	3605	3905	3905	3905	3905	4670	4670	
Width	mm	1110	1110	1110	1110	1110	1110	1110	1110	1110	1110	1110	1110	
Height	mm	1703	1703	1703	1769	1769	1769	2297	2297	2297	2297	2231	2231	
Weight	kg	1810	1810	1810	1870	1680	1750	2010	2030	2490	2630	3100	3110	

- Data referred to the following conditions:
  - Ambient air temperature 35 °C
  - Evaporator water inlet–outlet temperature 12–7 °C

R410A, 2 Circuit, 4-Compressor Units

Refrigerant R410A															
Unit ACSC40.....24A	170	180	205	230	260	280	330	370	410						
<b>Performance data</b>															
Cooling Capacity	kW	170	181	207	229	259	281	330	371	410					
Total Power Input	kW	49	53	61	68	77	86	99	114	131					
EER	kW/kW	3.46	3.39	3.41	3.36	3.35	3.27	3.33	3.26	3.14					
Energy Class	-	AA	AA	AA	AA	AA	A	AA	A	A					
<b>General Unit Data</b>															
Number of Independent Refrigerant Circuits	-	2	2	2	2	2	2	2	2	2					
Refrigerant Charge	kg	49	49	53	56	55	56	71	68	68					
Oil Charge	Liters	6.5 / 6.5	6.5 / 6.5	7.92 / 7.92	9.34 / 9.34	9.34 / 9.34	9.34 / 9.34	10.97 / 10.97	12.6 / 12.6	12.6 / 12.6					
Compressors, Scroll Qty per Chiller	-	4	4	4	4	4	4	4	4	4					
<b>Condensers, High Efficiency Fin/Tube with Integral Subcooler</b>															
Number of Rows		4	4	4	4	4	4	4	4	4					
Fins per inch		12	12	12	12	12	12	12	12	12					
<b>Condenser Fans</b>															
Type		Axial													
Number		4	4	4	4	6	6	6	8	8					
Fan Motor	kW	1.9	1.9	1.9	1.9	1.9	1.9	1.9	1.9	1.9					
Fan & Motor Speed	RPM	900	900	900	900	900	900	900	900	900					
Fan Diameter	mm	800	800	800	800	800	800	800	800	800					
<b>Evaporator, Direct Expansion</b>															
Type		Shell & Tube Heat Exchanger													
Water Flow Rate	l/min	486.7	518.3	593.3	653.3	740.0	805.0	943.3	1061.7	1173.3					
Cooler pressure drop	kpa	19	21	31	34	43	51	59	75	90					
Maximum Water Side Pressure	Bar	10	10	10	10	10	10	10	10	10					
Maximum Refrigerant Side Pressure	Bar	27	27	27	27	27	27	27	27	27					
Maximum Chilled Water Flow Rate	l/min	584.0	622.0	712.0	784.0	888.0	966.0	1132.0	1274.0	1408.0					
Minimum Chilled Water Flow Rate	l/min	340.7	362.8	415.3	457.3	518.0	563.5	660.3	743.2	821.3					
Nominal Water Connections size	Inches	3		3.5		4									
<b>Electrical</b>															
Power Supply	V/Ph/Hz	380~420/3/50													
<b>Dimension &amp; Weight</b>															
Length	mm	3605	3605	3605	3605	3760	3760	4405	4670	4670					
Width	mm	2305	2305	2305	2305	2305	2305	2305	2305	2305					
Height	mm	2165	2165	2165	2165	2165	2165	2165	2231	2231					
Weight	kg	3290	3290	3570	3730	4600	4640	5130	5990	6020					

- Data referred to the following conditions:
  - Ambient air temperature 35 °C
  - Evaporator water inlet–outlet temperature 12–7 °C

R407C, 1 Circuit, 2-Compressor Units

Refrigerant R407C												
Unit ACSC20.....14C	050	060	065	070	085	095	110	115	140	150	165	
<b>Performance data</b>												
Cooling Capacity	kW	49	59	66	70	86	96	108	117	140	152	167
Total Power Input	kW	16	19	22	24	28	33	36	41	46	52	56
EER	kW/kW	3.01	3.08	3.01	2.96	3.06	2.93	2.96	2.83	3.04	2.95	2.97
Energy Class	-	B	B	B	B	B	B	B	C	B	B	B
<b>General Unit Data</b>												
Number of Independent Refrigerant Circuits	-	1	1	1	1	1	1	1	1	1	1	1
Refrigerant Charge	kg	12	13	13	16	20	21	29	29	30	30	31
Oil Charge	Liters	6.5 / 0	6.5 / 0	6.5 / 0	6.74 / 0	6.76 / 0	8.05 / 0	9.34 / 0	10.97 / 0	12.6 / 0	12.6 / 0	12.6 / 0
Compressors, Scroll Qty per Chiller	-	2	2	2	2	2	2	2	2	2	2	2
<b>Condensers, High Efficiency Fin/Tube with Integral Subcooler</b>												
Number of Rows		3	3	3	4	4	4	4	4	4	4	4
Fins per inch		12	12	12	12	12	12	12	12	12	12	12
<b>Condenser Fans</b>												
Type		Axial										
Number		3	3	3	3	2	2	2	2	3	3	4
Fan Motor	kW	1.1	1.1	1.1	1.1	1.9	1.9	1.9	1.9	1.9	1.9	1.9
Fan & Motor Speed	RPM	900	900	900	900	900	900	900	900	900	900	900
Fan Diameter	mm	710	710	710	710	800	800	800	800	800	800	800
<b>Evaporator, Direct Expansion</b>												
Type		Shell & Tube Heat Exchanger										
Water Flow Rate	l/min	141.7	170.0	188.3	201.7	245.0	273.3	306.7	333.3	401.7	433.3	478.3
Cooler pressure drop	kpa	7	3	4	4	10	13	16	18	14	16	19
Maximum Water Side Pressure	Bar	10	10	10	10	10	10	10	10	10	10	10
Maximum Refrigerant Side Pressure	Bar	27	27	27	27	27	27	27	27	27	27	27
Maximum Chilled Water Flow Rate	l/min	170.0	204.0	226.0	242.0	294.0	328.0	368.0	400.0	482.0	520.0	574.0
Minimum Chilled Water Flow Rate	l/min	99.2	119.0	131.8	141.2	171.5	191.3	214.7	233.3	281.2	303.3	334.8
Nominal Water Connections size	Inches	1			2				3			
<b>Electrical</b>												
Power Supply	V/Ph/Hz	380~420/3/50										
<b>Dimension &amp; Weight</b>												
Length	mm	3050	3050	3050	3050	3605	3605	3905	3905	3905	3905	4670
Width	mm	1110	1110	1110	1110	1110	1110	1110	1110	1110	1110	1110
Height	mm	1703	1703	1703	1769	1769	1769	2297	2297	2297	2297	2231
Weight	kg	1730	1790	1790	1850	1560	1640	1900	1920	2470	2490	2970

- Data referred to the following conditions:
  - Ambient air temperature 35 °C
  - Evaporator water inlet–outlet temperature 12–7 °C

R407C, 2 Circuit, 4-Compressor Units

Refrigerant R407C												
Unit ACSC40.....24C	165	175	195	230	260	280	310	340				
<b>Performance data</b>												
Cooling Capacity	kW	165	175	196	228	260	280	311	342			
Total Power Input	kW	51	55	64	75	85	94	103	113			
EER	kW/kW	3.25	3.17	3.05	3.05	3.07	2.97	3.03	3.02			
Energy Class	-	A	A	B	B	B	B	B	B			
<b>General Unit Data</b>												
Number of Independent Refrigerant Circuits	-	2	2	2	2	2	2	2	2			
Refrigerant Charge	kg	45	45	46	50	54	54	62	61			
Oil Charge	Liters	6.75 / 6.75	6.76 / 6.76	8.05 / 8.05	9.34 / 9.34	10.97 / 10.97	12.6 / 12.6	12.6 / 12.6	12.6 / 12.6			
Compressors, Scroll Qty per Chiller	-	4	4	4	4	4	4	4	4			
<b>Condensers, High Efficiency Fin/Tube with Integral Subcooler</b>												
Number of Rows		4	4	4	4	4	4	4	4			
Fins per inch		12	12	12	12	12	12	12	12			
<b>Condenser Fans</b>												
Type		Axial										
Number		4	4	4	4	6	6	6	8			
Fan Motor	kW	1.9	1.9	1.9	1.9	1.9	1.9	1.9	1.9			
Fan & Motor Speed	RPM	900	900	900	900	900	900	900	900			
Fan Diameter	mm	800	800	800	800	800	800	800	800			
<b>Evaporator, Direct Expansion</b>												
Type		Shell & Tube Heat Exchanger										
Water Flow Rate	l/min	471.7	500.0	560.0	653.3	743.3	801.7	888.3	976.7			
Cooler pressure drop	kpa	22	25	29	33	16	18	37	40			
Maximum Water Side Pressure	Bar	10	10	10	10	10	10	10	10			
Maximum Refrigerant Side Pressure	Bar	27	27	27	27	27	27	27	27			
Maximum Chilled Water Flow Rate	l/min	566.0	600.0	672.0	784.0	892.0	962.0	1066.0	1172.0			
Minimum Chilled Water Flow Rate	l/min	330.2	350.0	392.0	457.3	520.3	561.2	621.8	683.7			
Nominal Water Connections size	Inches	3		3.5		4						
<b>Electrical</b>												
Power Supply	V/Ph/Hz	380~420/3/50										
<b>Dimension &amp; Weight</b>												
Length	mm	3605	3605	3605	3605	3760	3760	4405	4670			
Width	mm	2305	2305	2305	2305	2305	2305	2305	2305			
Height	mm	2165	2165	2165	2165	2165	2165	2165	2231			
Weight	kg	3290	3290	3430	3600	4620	4670	4930	5790			

- Data referred to the following conditions:
  - Ambient air temperature 35 °C
  - Evaporator water inlet–outlet temperature 12–7 °C



## Dimensions and Clearances

Note: Dimension may change! take last update of all model's dimension by contact Arvand experts.

### R410A, 1-Circuit

Model	W (mm)	H (mm)	L (mm)	A (mm)	B (mm)
ACSC2005514A	1110	1703	3050	1000	2000
ACSC2006014A	1110	1703	3050	1000	2000
ACSC2006514A	1110	1703	3050	1000	2000
ACSC2007514A	1110	1769	3050	1000	2000
ACSC2009014A	1110	1769	3605	1000	2000
ACSC2010514A	1110	1769	3605	1000	2000
ACSC2011514A	1110	2297	3905	1000	2000
ACSC2013014A	1110	2297	3905	1000	2000
ACSC2014514A	1110	2297	3905	1000	2000
ACSC2016514A	1110	2297	3905	1000	2000
ACSC2018514A	1110	2231	4670	1000	2000
ACSC2020514A	1110	2231	4670	1000	2000

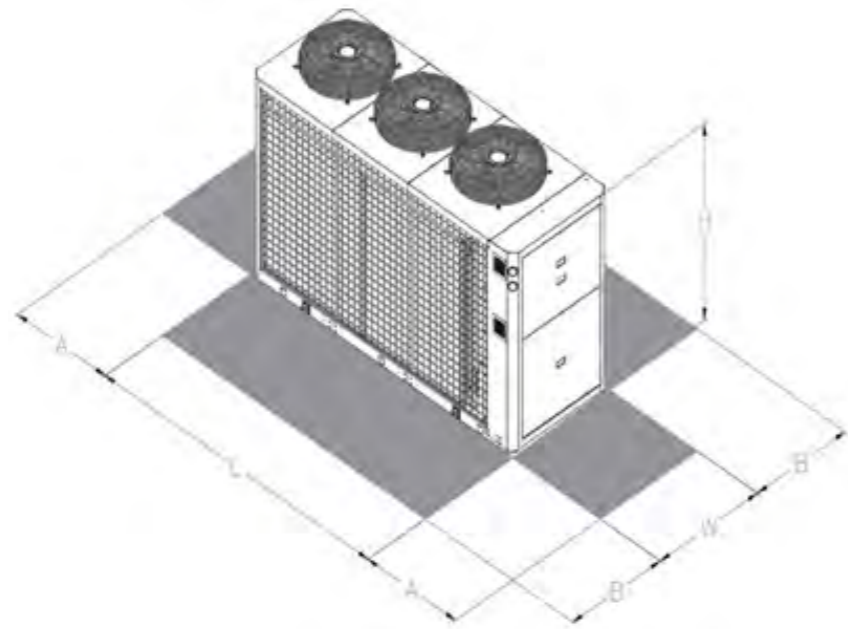

### R407C, 1-Circuit

Model	W (mm)	H (mm)	L (mm)	A (mm)	B (mm)
ACSC2005014C	1110	1703	3050	1000	2000
ACSC2006014C	1110	1703	3050	1000	2000
ACSC2006514C	1110	1703	3050	1000	2000
ACSC2007014C	1110	1769	3050	1000	2000
ACSC2008514C	1110	1769	3605	1000	2000
ACSC2009514C	1110	1769	3605	1000	2000
ACSC2011014C	1110	2297	3905	1000	2000
ACSC2011514C	1110	2297	3905	1000	2000
ACSC2014014C	1110	2297	3905	1000	2000
ACSC2015014C	1110	2297	3905	1000	2000
ACSC2016514C	1110	2231	4670	1000	2000

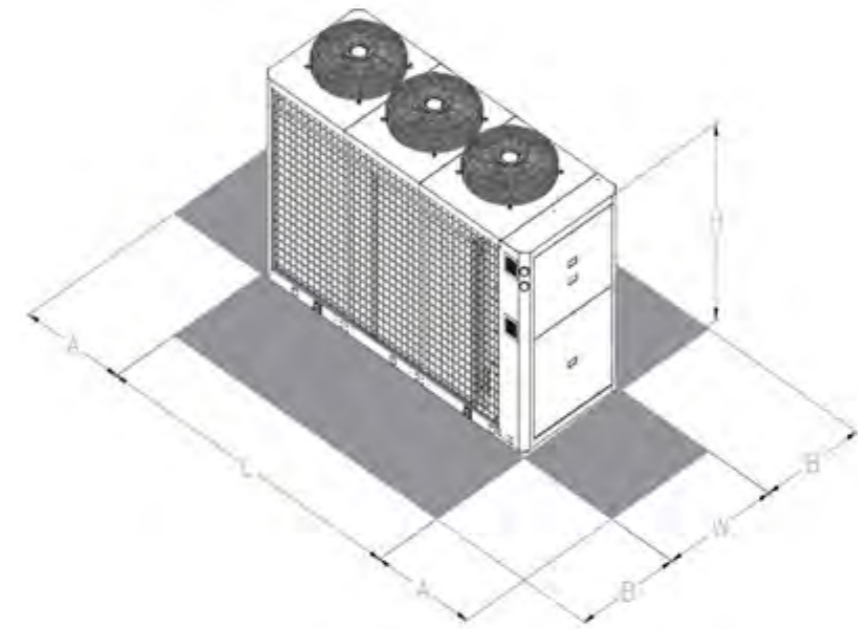

### R410A,2-Circuit

Model	W (mm)	H (mm)	L (mm)	A (mm)	B (mm)
ACSC4017024A	2305	2165	3605	1000	2000
ACSC4018024A	2305	2165	3605	1000	2000
ACSC4020524A	2305	2165	3605	1000	2000
ACSC4023024A	2305	2165	3605	1000	2000
ACSC4026024A	2305	2165	3760	1000	2000
ACSC4028024A	2305	2165	3760	1000	2000
ACSC4033024A	2305	2165	4405	1000	2000
ACSC4037024A	2305	2231	4670	1000	2000
ACSC4041024A	2305	2231	4670	1000	2000

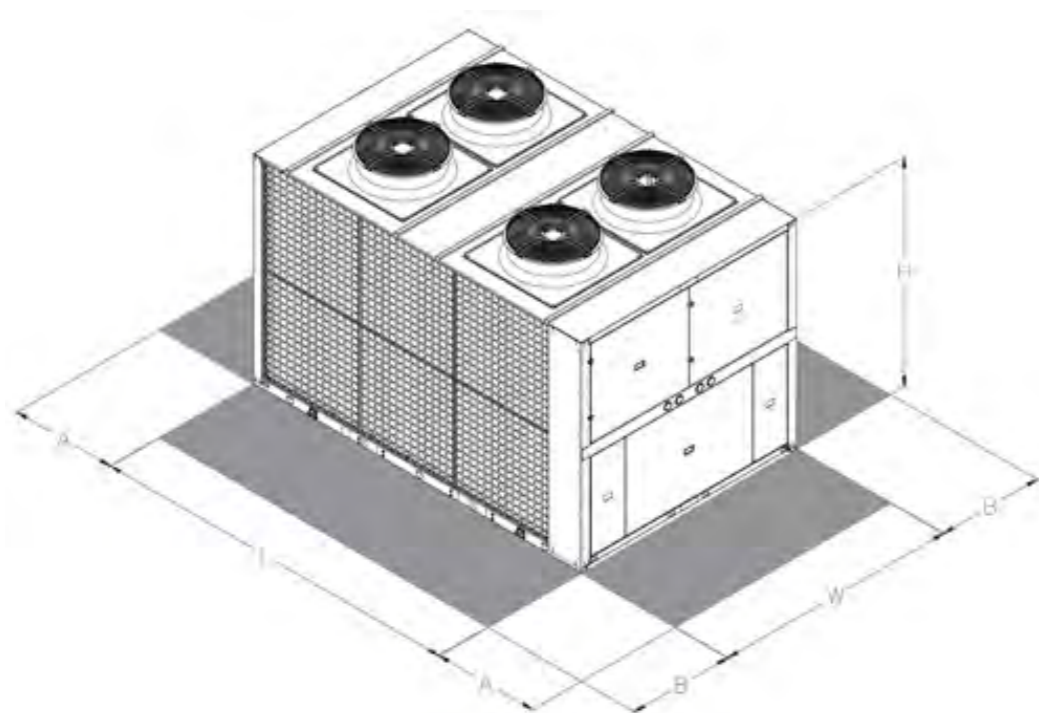

### R407C,2-Circuit

Model	W (mm)	H (mm)	L (mm)	A (mm)	B (mm)
ACSC4016524C	2305	2165	3605	1000	2000
ACSC4017524C	2305	2165	3605	1000	2000
ACSC4019524C	2305	2165	3605	1000	2000
ACSC4023024C	2305	2165	3605	1000	2000
ACSC4026024C	2305	2165	3760	1000	2000
ACSC4028024C	2305	2165	3760	1000	2000
ACSC4031024C	2305	2165	4405	1000	2000
ACSC4034024C	2305	2231	4670	1000	2000

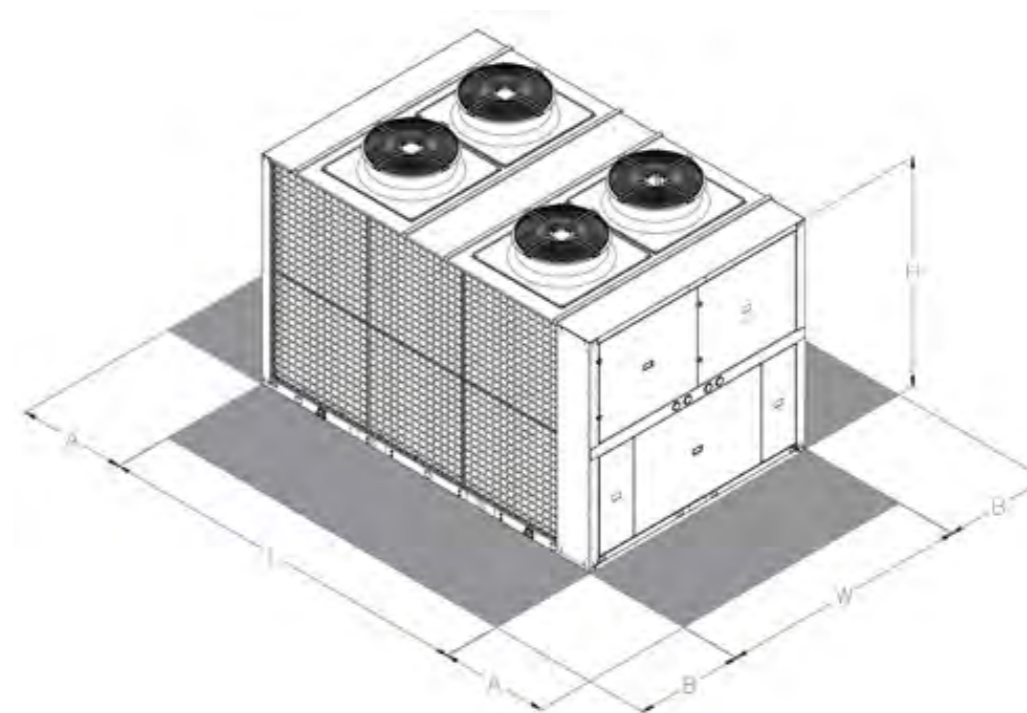

# Performance Data

## R-410A, 1- Circuit Units

Model: ACSC200514A																													
Ambient Temperature (°C)																													
CWT	30				35				40				43				46				50				52				MAT
	Q	P	WFR	Pd	Q	P	WFR	Pd	Q	P	WFR	Pd	Q	P	WFR	Pd	Q	P	WFR	Pd	Q	P	WFR	Pd	Q	P	WFR	Pd	
5	52.2	14.9	8.9	10.0	49.5	16.1	8.5	9.0	46.7	17.6	8.0	8.0	44.9	18.5	7.7	7.0	43.1	19.6	7.4	7.0	40.5	21.1	6.9	6.0	39.2	21.9	6.7	6.0	52
6	54.1	14.9	9.3	11.0	51.3	16.2	8.8	10.0	48.4	17.6	8.3	9.0	46.6	18.6	8.0	8.0	44.7	19.6	7.7	7.0	42.1	21.1	7.2	7.0	40.7	21.9	7.0	6.0	52
7	55.7	15.0	9.5	11.0	52.8	16.3	9.1	10.0	49.8	17.7	8.5	9.0	47.9	18.7	8.2	8.0	46.0	19.7	7.9	8.0	43.3	21.2	7.4	7.0	42.0	22.0	7.2	7.0	52
8	57.7	15.1	9.9	12.0	54.7	16.3	9.4	11.0	51.6	17.8	8.8	10.0	49.7	18.7	8.5	9.0	47.7	19.8	8.2	8.0	45.0	21.3	7.7	7.0	43.6	22.1	7.5	7.0	52
9	59.5	15.1	10.2	12.0	56.4	16.4	9.7	11.0	53.2	17.9	9.1	10.0	51.3	18.8	8.8	9.0	49.2	19.9	8.4	9.0	46.5	21.4	8.0	8.0	45.0	22.2	7.7	7.0	52
10	61.1	15.2	10.5	13.0	57.9	16.5	9.9	12.0	54.7	17.9	9.4	11.0	52.7	18.9	9.0	10.0	50.6	19.9	8.7	9.0	47.8	21.4	8.2	8.0	46.3	22.2	7.9	8.0	52

Model: ACSC2006014A																													
Ambient Temperature (°C)																													
CWT	30				35				40				43				46				50				52				MAT
	Q	P	WFR	Pd	Q	P	WFR	Pd	Q	P	WFR	Pd	Q	P	WFR	Pd	Q	P	WFR	Pd	Q	P	WFR	Pd	Q	P	WFR	Pd	
5	59.4	17.1	10.2	12.0	56.4	18.7	9.7	11.0	53.1	20.4	9.1	10.0	51.1	21.5	8.8	9.0	48.9	22.8	8.4	9.0	45.9	24.5	7.9	8.0					51
6	61.5	17.2	10.5	13.0	58.3	18.8	10.0	12.0	55.0	20.5	9.4	11.0	52.9	21.6	9.1	10.0	50.7	22.9	8.7	9.0	47.7	24.6	8.2	8.0					51
7	63.3	17.3	10.9	14.0	60.1	18.9	10.3	13.0	56.6	20.6	9.7	11.0	54.5	21.7	9.3	11.0	52.2	23.0	8.9	10.0	49.1	24.7	8.4	9.0					51
8	65.5	17.4	11.2	15.0	62.2	19.0	10.7	13.0	58.6	20.7	10.0	12.0	56.4	21.8	9.7	11.0	54.1	23.1	9.3	10.0	50.9	24.8	8.7	9.0					51
9	67.5	17.5	11.6	16.0	64.1	19.1	11.0	14.0	60.4	20.8	10.4	13.0	58.2	21.9	10.0	12.0	55.8	23.2	9.6	11.0	52.6	24.9	9.0	10.0					51
10	69.3	17.6	11.9	16.0	65.8	19.1	11.3	15.0	62.1	20.9	10.6	13.0	59.8	22.0	10.3	12.0	57.4	23.3	9.8	12.0	54.1	25.0	9.3	10.0					51

Model: ACSC2006514A																													
Ambient Temperature (°C)																													
CWT	30				35				40				43				46				50				52				MAT
	Q	P	WFR	Pd	Q	P	WFR	Pd	Q	P	WFR	Pd	Q	P	WFR	Pd	Q	P	WFR	Pd	Q	P	WFR	Pd	Q	P	WFR	Pd	
5	64.3	18.8	11.0	14.0	60.7	20.6	10.4	13.0	56.8	22.6	9.7	11.0	54.3	23.9	9.3	11.0	51.6	25.3	8.8	10.0	47.9	27.3	8.2	8.0					50
6	66.5	18.9	11.4	15.0	62.8	20.7	10.8	14.0	58.8	22.7	10.1	12.0	56.3	24.1	9.7	11.0	53.6	25.5	9.2	10.0	49.8	27.5	8.5	9.0					50
7	68.5	19.0	11.7	16.0	64.6	20.8	11.1	15.0	60.5	22.8	10.4	13.0	58.0	24.2	9.9	12.0	55.2	25.6	9.5	11.0	51.4	27.6	8.8	10.0					50
8	70.8	19.1	12.1	17.0	66.9	20.9	11.5	15.0	62.7	23.0	10.7	14.0	60.1	24.3	10.3	13.0	57.3	25.7	9.8	12.0	53.4	27.8	9.2	10.0					50
9	73.0	19.2	12.5	18.0	68.9	21.0	11.8	16.0	64.6	23.1	11.1	14.0	61.9	24.4	10.6	13.0	59.1	25.9	10.1	12.0	55.1	27.9	9.4	11.0					50
10	74.9	19.3	12.8	19.0	70.8	21.1	12.1	17.0	66.4	23.2	11.4	15.0	63.6	24.5	10.9	14.0	60.8	26.0	10.4	13.0	56.7	28.0	9.7	11.0					50

Model: ACSC2007514A																													
Ambient Temperature (°C)																													
CWT	30				35				40				43				46				50				52				MAT
	Q	P	WFR	Pd	Q	P	WFR	Pd	Q	P	WFR	Pd	Q	P	WFR	Pd	Q	P	WFR	Pd	Q	P	WFR	Pd	Q	P	WFR	Pd	
5	73.0	20.8	12.5	18.0	69.1	22.7	11.8	16.0	64.8	24.9	11.1	15.0	62.2	26.3	10.7	14.0	59.4	27.8	10.2	12.0	55.4	30.0	9.5	11.0					51
6	75.4	21.0	12.9	19.0	71.4	22.9	12.2	17.0	67.0	25.0	11.5	16.0	64.3	26.5	11.0	14.0	61.4	28.0	10.5	13.0	57.4	30.1	9.8	12.0					51
7	77.6	21.1	13.3	20.0	73.4	23.0	12.6	18.0	69.0	25.2	11.8	16.0	66.1	26.6	11.3	15.0	63.2	28.1	10.8	14.0	59.0	30.3	10.1	12.0					51
8	80.2	21.3	13.7	22.0	75.9	23.2	13.0	19.0	71.3	25.4	12.2	17.0	68.4	26.8	11.7	16.0	65.3	28.3	11.2	15.0	61.1	30.5	10.5	13.0					51
9	82.6	21.4	14.2	23.0	78.1	23.3	13.4	20.0	73.4	25.5	12.6	18.0	70.4	26.9	12.1	17.0	67.3	28.5	11.5	16.0	62.9	30.6	10.8	14.0					51
10	84.7	21.5	14.5	24.0	80.2	23.5	13.7	21.0	75.3	25.7	12.9	19.0	72.2	27.1	12.4	18.0	69.0	28.6	11.8	16.0	64.6	30.8	11.1	14.0					51

Model: ACSC2009014A																													
Ambient Temperature (°C)																													
CWT	30				35				40				43				46				50				52				MAT
	Q	P	WFR	Pd	Q	P	WFR	Pd	Q	P	WFR	Pd	Q	P	WFR	Pd	Q	P	WFR	Pd	Q	P	WFR	Pd	Q	P	WFR	Pd	
5	92.3	24.6	15.8	23.0	86.8	27.1	14.9	21.0	81.0	29.9	13.9	18.0	77.4	31.7	13.3	17.0	73.7	33.7	12.6	16.0	68.8	36.5	11.8	14.0					51
6	95.2	24.7	16.3	25.0	89.6	27.2	15.4	22.0	83.6	30.0	14.3	19.0	80.0	31.8	13.7	18.0	76.2	33.8	13.1	16.0	71.2	36.6	12.2	15.0					51
7	97.9	24.8	16.8	26.0	92.1	27.3	15.8	23.0	86.1	30.1	14.8	20.0	82.3	31.9	14.1	19.0	78.5	33.9	13.5	17.0	73.4	36.8	12.6	15.0					51
8	101.1	24.9	17.3	27.0	95.1	27.4	16.3	24.0	88.9	30.2	15.2	22.0	85.1	32.1	14.6	20.0	81.2	34.1	13.9	18.0	75.9	36.9	13.0	16.0					51
9	104.0	25.0	17.8	29.0	97.9	27.6	16.8	26.0	91.6	30.4	15.7	23.0	87.7	32.2	15.0	21.0	83.7	34.2	14.3	19.0	78.3	37.0	13.4	17.0					51
10	106.8	25.1	18.3	30.0	100.5	27.7	17.2	27.0	94.1	30.5	16.1	24.0	90.1	32.3	15.4	22.0	86.0	34.3	14.7	20.0	80.5	37.2	13.8	18.0					51

- Q; Cooling Capacity in kW
- P; Total Power Absorbed in kW
- WFR; Water Flow Rate in m<sup>3</sup>/hr.
- Pd; Water Pressure Drop in kPa
- CWT; Chilled Water Temperature in °C (ΔT = 5°C)
- MAT; Maximum Ambient Temperature in °C
- NOTES:

- Waterflow and pressure drop on heat exchangers calculated with 5°C of delta T
- Interpolation between rating is permissible but extrapolation is not.

## R-410A, 1- Circuit Units

Model: ACSC2010514A																													
Ambient Temperature (°C)																													
CWT	30				35				40				43				46				50				52				MAT
	Q	P	WFR	Pd	Q	P	WFR	Pd	Q	P	WFR	Pd	Q	P	WFR	Pd	Q	P	WFR	Pd	Q	P	WFR	Pd	Q	P	WFR	Pd	
5	103.0	27.9	17.7	29.0	97.1	30.7	16.6	26.0	90.9	33.7	15.6	23.0	87.1	35.7	14.9	21.0	83.1	37.8	14.2	19.0									49
6	106.3	28.1	18.2	30.0	100.2	30.8	17.2	27.0	93.9	33.9	16.1	24.0	89.9	35.9	15.4	22.0	85.9	38.0	14.7	20.0									49
7	109.3	28.2	18.7	32.0	103.1	31.0	17.7	28.0	96.6	34.1	16.6	25.0	92.5	36.1	15.9	23.0	88.4	38.2	15.2	21.0									49
8	112.8	28.4	19.3	33.0	106.5	31.2	18.3	30.0	99.8	34.3	17.1	27.0	95.6	36.3	16.4	25.0	91.3	38.5	15.7	23.0									49
9	116.1	28.6	19.9	35.0	109.6	31.4	18.8	31.0	102.7	34.5	17.6	28.0	98.5	36.5	16.9	26.0	94.1	38.7	16.1	24.0									49
10	119.2	28.7	20.4	37.0	112.5	31.5	19.3	33.0	105.5	34.7	18.1	29.0	101.1	36.7	17.3	27.0	96.7	38.9	16.6	25.0									49

Model: ACSC2011514A																													
Ambient Temperature (°C)																													
CWT	30				35				40				43				46				50				52				MAT
	Q	P	WFR	Pd	Q	P	WFR	Pd	Q	P	WFR	Pd	Q	P	WFR	Pd	Q	P	WFR	Pd	Q	P	WFR	Pd	Q	P	WFR	Pd	
5	115.7	30.3	19.8	35.0	109.5	33.2	18.8	32.0	102.9	36.4	17.6	28.0	98.8	38.5	16.9	26.0	94.6	40.7	16.2	24.0	88.9	43.8	15.2	22.0					50
6	119.4	30.5	20.5																										

# Performance Data

## R-410A, 1- Circuit Units

Model: ACSC2018514A																													
CWT	Ambient Temperature (°C)																										MAT		
	30				35				40				43				46				50				52				
	Q	P	WFR	Pd	Q	P	WFR	Pd	Q	P	WFR	Pd	Q	P	WFR	Pd	Q	P	WFR	Pd	Q	P	WFR	Pd	Q	P		WFR	Pd
5	186.6	51.7	32.0	40.0	176.2	56.3	30.2	36.0	165.5	61.6	28.4	32.0	158.8	65.1	27.2	30.0	152.1	68.8	26.1	27.0									49
6	192.6	52.1	33.0	42.0	181.9	56.7	31.2	38.0	170.8	62.0	29.3	34.0	164.0	65.5	28.1	31.0	157.0	69.3	26.9	29.0									49
7	198.3	52.5	34.0	44.0	187.3	57.1	32.1	40.0	175.9	62.4	30.2	36.0	168.8	65.9	28.9	33.0	161.7	69.7	27.7	30.0									49
8	204.8	52.9	35.1	47.0	193.4	57.6	33.2	42.0	181.7	62.9	31.1	38.0	174.4	66.4	29.9	35.0	167.0	70.2	28.6	32.0									49
9	210.9	53.4	36.2	50.0	199.2	58.0	34.1	45.0	187.1	63.4	32.1	40.0	179.6	66.9	30.8	37.0	172.0	70.7	29.5	34.0									49
10	216.5	53.8	37.1	52.0	204.6	58.5	35.1	47.0	192.1	63.8	32.9	42.0	184.5	67.3	31.6	39.0	176.7	71.1	30.3	36.0									49

Model: ACSC2020514A																													
CWT	Ambient Temperature (°C)																										MAT		
	30				35				40				43				46				50				52				
	Q	P	WFR	Pd	Q	P	WFR	Pd	Q	P	WFR	Pd	Q	P	WFR	Pd	Q	P	WFR	Pd	Q	P	WFR	Pd	Q	P		WFR	Pd
5	206.8	59.2	35.5	48.0	195.3	64.4	33.5	43.0	183.3	70.4	31.4	39.0	175.8	74.2	30.1	36.0	168.2	78.4	28.8	33.0									48
6	213.3	59.7	36.6	51.0	201.4	65.0	34.5	46.0	189.0	70.9	32.4	41.0	181.4	74.8	31.1	38.0	173.5	79.0	29.7	35.0									48
7	219.3	60.2	37.6	54.0	207.1	65.5	35.5	48.0	194.4	71.5	33.3	43.0	186.6	75.4	32.0	40.0	178.5	79.6	30.6	37.0									48
8	226.3	60.8	38.8	57.0	213.8	66.1	36.7	51.0	200.7	72.1	34.4	45.0	192.5	76.0	33.0	42.0	184.3	80.2	31.6	39.0									48
9	232.9	61.4	39.9	60.0	219.9	66.7	37.7	54.0	206.5	72.7	35.4	48.0	198.1	76.7	34.0	44.0	189.6	80.8	32.5	41.0									48
10	239.0	61.9	41.0	63.0	225.7	67.3	38.7	56.0	211.9	73.3	36.3	50.0	203.4	77.2	34.9	46.0	194.6	81.4	33.4	43.0									48

- Q; Cooling Capacity in kW
- P; Total Power Absorbed in kW
- WFR; Water Flow Rate in m3/hr.
- Pd; Water Pressure Drop in kPa
- CWT; Chilled Water Temperature in °C (ΔT = 5°C)
- MAT; Maximum Ambient Temperature in °C
- NOTES:
  - I. Waterflow and pressure drop on heat exchangers calculated with 5°C of delta T
  - II. Interpolation between rating is permissible but extrapolation is not.

## R-410A, 2-Circuit Units

Model: ACSC4017024A																													
CWT	Ambient Temperature (°C)																												MAT
	30				35				40				43				46				50				52				
	Q	P	WFR	Pd	Q	P	WFR	Pd	Q	P	WFR	Pd	Q	P	WFR	Pd	Q	P	WFR	Pd	Q	P	WFR	Pd	Q	P	WFR	Pd	
5	169.0	44.6	29.0	19.0	159.8	48.8	27.4	17.0	150.0	53.4	25.7	15.0	143.8	56.6	24.7	14.0	137.6	60.0	23.6	13.0	128.8	64.8	22.1	11.0	124.2	67.4	21.3	11.0	53
6	174.4	44.8	29.9	20.0	165.0	49.0	28.3	18.0	155.0	53.6	26.6	16.0	148.6	56.8	25.5	15.0	142.2	60.2	24.4	14.0	133.2	65.0	22.8	12.0	128.6	67.6	22.0	11.0	53
7	179.6	45.0	30.8	21.0	169.8	49.2	29.1	19.0	159.6	53.8	27.4	17.0	153.2	57.0	26.3	16.0	146.4	60.4	25.1	14.0	137.2	65.2	23.5	13.0	132.6	67.8	22.7	12.0	53
8	185.4	45.2	31.8	22.0	175.4	49.4	30.1	20.0	164.8	54.2	28.3	18.0	158.2	57.2	27.1	16.0	151.4	60.6	26.0	15.0	142.0	65.4	24.3	13.0	137.2	68.0	23.5	13.0	53
9	191.0	45.4	32.7	23.0	180.6	49.6	31.0	21.0	169.8	54.4	29.1	19.0	163.0	57.6	27.9	17.0	156.0	60.8	26.7	16.0	146.4	65.8	25.1	14.0	141.4	68.4	24.2	13.0	53
10	196.2	45.6	33.6	24.0	185.6	49.8	31.8	22.0	174.4	54.6	29.9	20.0	167.6	57.8	28.7	18.0	160.4	61.2	27.5	17.0	150.6	66.0	25.8	15.0	145.4	68.6	24.9	14.0	53

Model: ACSC4018024A																													
CWT	Ambient Temperature (°C)																												MAT
	30				35				40				43				46				50				52				
	Q	P	WFR	Pd	Q	P	WFR	Pd	Q	P	WFR	Pd	Q	P	WFR	Pd	Q	P	WFR	Pd	Q	P	WFR	Pd	Q	P	WFR	Pd	
5	180.8	48.2	31.0	21.0	170.4	53.0	29.2	19.0	159.4	58.6	27.3	17.0	152.6	62.0	26.2	15.0	145.6	66.0	25.0	14.0	136.0	71.6	23.3	13.0	131.2	74.6	22.5	12.0	52
6	186.4	48.4	32.0	22.0	175.8	53.2	30.1	20.0	164.6	58.8	28.2	18.0	157.6	62.4	27.0	16.0	150.4	66.2	25.8	15.0	140.8	71.8	24.1	13.0	135.8	74.8	23.3	12.0	52
7	191.8	48.6	32.9	24.0	181.0	53.4	31.0	21.0	169.4	59.0	29.0	19.0	162.4	62.6	27.8	17.0	155.0	66.4	26.6	16.0	145.2	72.0	24.9	14.0	140.0	75.0	24.0	13.0	52
8	198.0	48.8	33.9	25.0	186.8	53.6	32.0	22.0	175.0	59.2	30.0	20.0	167.8	62.8	28.8	18.0	160.4	66.6	27.5	17.0	150.2	72.2	25.7	15.0	145.0	75.2	24.9	14.0	52
9	203.8	49.0	34.9	26.0	192.4	53.8	33.0	24.0	180.4	59.4	30.9	21.0	172.8	63.0	29.6	19.0	165.2	66.8	28.3	18.0	155.0	72.4	26.6	16.0	149.6	75.4	25.6	15.0	52
10	209.4	49.2	35.9	28.0	197.6	54.0	33.9	25.0	185.2	59.6	31.7	22.0	177.6	63.2	30.4	20.0	170.0	67.0	29.1	19.0	159.4	72.6	27.3	17.0	154.0	75.6	26.4	16.0	52

Model: ACSC4020524A																													
CWT	Ambient Temperature (°C)																												MAT
	30				35				40				43				46				50				52				
	Q	P	WFR	Pd	Q	P	WFR	Pd	Q	P	WFR	Pd	Q	P	WFR	Pd	Q	P	WFR	Pd	Q	P	WFR	Pd	Q	P	WFR	Pd	
5	206.8	54.8	35.5	32.0	195.2	60.2	33.5	28.0	183.0	66.0	31.4	25.0	175.4	70.0	30.1	23.0	167.6	74.2	28.7	21.0	157.0	80.0	26.9	19.0					50
6	213.2	55.0	36.5	34.0	201.4	60.4	34.5	30.0	189.0	66.4	32.4	27.0	181.2	70.4	31.1	25.0	173.2	74.6	29.7	23.0	162.2	80.4	27.8	20.0					50
7	219.4	55.2	37.6	35.0	207.2	60.8	35.5	32.0	194.4	66.8	33.3	28.0	186.6	70.6	32.0	26.0	178.4	74.8	30.6	24.0	167.2	80.8	28.7	21.0					50
8	226.4	55.6	38.8	37.0	214.0	61.0	36.7	34.0	200.8	67.2	34.4	30.0	192.6	71.0	33.0	28.0	184.4	75.2	31.6	25.0	173.0	81.2	29.7	22.0					50
9	233.0	55.8	39.9	40.0	220.2	61.4	37.7	36.0	206.8	67.4	35.5	32.0	198.6	71.4	34.0	29.0	190.0	75.6	32.6	27.0	178.2	81.8	30.5	24.0					50
10	239.2	56.2	41.0	42.0	226.2	61.6	38.8	37.0	212.6	67.8	36.4	33.0	204.0	71.8	35.0	31.0	195.2	76.0	33.5	28.0	183.2	82.0	31.4	25.0					50

Model: ACSC4023024A																													
CWT	Ambient Temperature (°C)																												MAT
	30				35				40				43				46				50				52				
	Q	P	WFR	Pd	Q	P	WFR	Pd	Q	P	WFR	Pd	Q	P	WFR	Pd	Q	P	WFR	Pd	Q	P	WFR	Pd	Q	P	WFR	Pd	
5	227.6	61.2	39.0	35.0	215.2	67.2	36.9	31.0	202.2	73.6	34.7	28.0	194.2	77.8	33.3	26.0	185.8	82.2	31.9	23.0									49
6	234.6	61.6	40.2	37.0	222.0	67.6	38.1	33.0	208.6	74.2	35.8	29.0	200.4	78.4	34.4	27.0	191.8	82.8	32.9	25.0									49
7	241.4	62.0	41.4	39.0	228.4	68.0	39.2	35.0	214.8	74.6	36.8	31.0	206.2	78.8	35.3	29.0	197.4	83.4	33.8	26.0									49
8	249.2	62.4	42.7	41.0	235.8	68.6	40.4	37.0	221.8	75.2	38.0	33.0	213.0	79.4	36.5	30.0	204.0	84.0	35.0	28.0									49
9	256.4	62.8	44.0	43.0	242.8	69.0	41.6	39.0	228.4	75.6	39.2	35.0	219.2	80.0	37.6	32.0	210.0	84.4	36.0	29.0									49
10	263.2	63.2	45.1	45.0	249.2	69.4	42.7	41.0	234.4	76.0	40.2	36.0	225.2	80.4	38.6	34.0	215.6	85.0	37.0	31.0									49

Model: ACSC4026024A																													
CWT	Ambient Temperature (°C)																												MAT
	30				35				40				43				46				50				52				
	Q	P	WFR	Pd	Q	P	WFR	Pd	Q	P	WFR	Pd	Q	P	WFR	Pd	Q	P	WFR	Pd	Q	P	WFR	Pd	Q	P	WFR	Pd	
5	257.2	70.0	44.1	44.0	243.8	76.6	41.8	39.0	229.6	83.8	39.4	35.0	220.6	88.4	37.8	33.0	211.4	93.4	36.2	30.0	199.0	100.6	34.1	27.0					51
6	265.2	70.4	45.5	46.0	251.6	77.0	43.1	42.0																					

R-410A, 2-Circuit Units

Model: ACSC4028024A																																				
CWT	Ambient Temperature (°C)																														MAT					
	30					35					40					43					46					50						52				
	Q	P	WFR	Pd		Q	P	WFR	Pd		Q	P	WFR	Pd		Q	P	WFR	Pd		Q	P	WFR	Pd		Q	P	WFR	Pd			Q	P	WFR	Pd	
5	280.2	78.0	48.0	52.0	265.4	85.4	45.5	46.0	249.8	93.6	42.8	41.0	239.8	99.0	41.1	38.0	229.8	104.8	39.4	35.0	216.0	113.2	37.0	31.0											50	
6	288.8	78.4	49.5	55.0	273.8	85.8	46.9	49.0	257.6	94.0	44.2	44.0	247.4	99.4	42.4	41.0	237.2	105.2	40.7	37.0	222.8	113.6	38.2	33.0												50
7	297.0	78.8	50.9	57.0	281.4	86.2	48.2	52.0	265.0	94.4	45.4	46.0	254.6	99.8	43.6	43.0	244.0	105.8	41.8	39.0	229.4	114.2	39.3	35.0												50
8	306.2	79.2	52.5	61.0	290.4	86.6	49.8	55.0	273.4	95.0	46.9	49.0	262.8	100.4	45.1	45.0	252.0	106.2	43.2	42.0	237.0	114.8	40.6	37.0												50
9	315.0	79.6	54.0	64.0	298.8	87.0	51.2	58.0	281.4	95.4	48.2	52.0	270.6	100.8	46.4	48.0	259.4	106.8	44.5	44.0	244.2	115.2	41.9	39.0												50
10	323.0	80.0	55.4	67.0	306.4	87.4	52.5	61.0	288.8	95.8	49.5	54.0	277.8	101.4	47.6	50.0	266.4	107.2	45.7	46.0	250.8	115.8	43.0	41.0												50

Model: ACSC4033024A																																							
CWT	Ambient Temperature (°C)																														MAT								
	30					35					40					43					46					50						52							
	Q	P	WFR	Pd		Q	P	WFR	Pd		Q	P	WFR	Pd		Q	P	WFR	Pd		Q	P	WFR	Pd		Q	P	WFR	Pd			Q	P	WFR	Pd		Q	P	WFR
5	328.8	89.6	56.4	60.0	310.8	97.8	53.3	54.0	292.0	107.2	50.1	48.0	280.4	113.4	48.1	44.0	268.4	120.2	46.0	41.0																	49		
6	339.0	90.2	58.1	64.0	320.6	98.4	55.0	57.0	301.2	108.0	51.6	51.0	289.2	114.2	49.6	47.0	276.8	120.8	47.5	43.0																		49	
7	348.8	90.8	59.8	67.0	329.8	99.2	56.5	60.0	310.0	108.6	53.1	54.0	297.6	114.8	51.0	49.0	285.0	121.6	48.9	46.0																		49	
8	359.8	91.4	61.7	71.0	340.2	99.8	58.3	64.0	319.8	109.4	54.8	57.0	307.0	115.6	52.6	52.0	294.0	122.4	50.4	48.0																		49	
9	370.2	92.0	63.5	75.0	350.2	100.6	60.0	67.0	329.2	110.0	56.4	60.0	316.0	116.4	54.2	55.0	302.8	123.2	51.9	51.0																		49	
10	380.2	92.6	65.2	79.0	359.6	101.2	61.6	71.0	338.2	110.8	58.0	63.0	324.8	117.2	55.7	58.0	311.2	124.0	53.3	54.0																		49	

Model: ACSC4037024A																																							
CWT	Ambient Temperature (°C)																														MAT								
	30					35					40					43					46					50						52							
	Q	P	WFR	Pd		Q	P	WFR	Pd		Q	P	WFR	Pd		Q	P	WFR	Pd		Q	P	WFR	Pd		Q	P	WFR	Pd			Q	P	WFR	Pd		Q	P	WFR
5	369.8	103.2	63.4	75.0	349.6	112.4	59.9	68.0	328.6	123.0	56.3	60.0	315.6	130.0	54.1	55.0	302.2	137.4	51.8	51.0	284.2	148.4	48.7	45.0													50		
6	381.6	104.0	65.4	80.0	360.6	113.2	61.8	72.0	339.0	123.8	58.1	64.0	325.6	130.8	55.8	59.0	311.8	138.4	53.5	54.0	293.2	149.2	50.3	48.0													50		
7	392.8	104.8	67.3	84.0	371.4	114.0	63.7	76.0	349.0	124.6	59.8	67.0	335.2	131.6	57.5	62.0	321.2	139.2	55.1	57.0	302.0	150.2	51.8	51.0													50		
8	405.4	105.6	69.5	90.0	383.2	115.0	65.7	80.0	360.2	125.6	61.7	71.0	346.0	132.6	59.3	66.0	331.4	140.2	56.8	61.0	311.6	151.2	53.4	54.0													50		
9	417.4	106.4	71.6	95.0	394.6	115.8	67.6	85.0	370.8	126.4	63.6	75.0	356.2	133.4	61.1	70.0	341.4	141.0	58.5	64.0	321.0	152.0	55.0	57.0													50		
10	429.0	107.2	73.5	100.0	405.6	116.6	69.5	90.0	381.2	127.4	65.3	79.0	366.2	134.4	62.8	73.0	350.8	142.0	60.1	68.0	330.0	153.0	56.6	60.0													50		

Model: ACSC4041024A																																							
CWT	Ambient Temperature (°C)																														MAT								
	30					35					40					43					46					50						52							
	Q	P	WFR	Pd		Q	P	WFR	Pd		Q	P	WFR	Pd		Q	P	WFR	Pd		Q	P	WFR	Pd		Q	P	WFR	Pd			Q	P	WFR	Pd		Q	P	WFR
5	409.4	118.0	70.2	92.0	387.0	128.6	66.3	82.0	363.4	140.4	62.3	73.0	348.8	148.2	59.8	67.0	334.0	156.6	57.3	62.0																		48	
6	422.0	119.0	72.3	97.0	398.8	129.6	68.4	87.0	374.6	141.6	64.2	77.0	359.6	149.4	61.6	71.0	344.4	157.6	59.0	66.0																		48	
7	434.2	120.0	74.4	102.0	410.4	130.6	70.4	92.0	385.4	142.6	66.1	81.0	370.0	150.4	63.4	75.0	354.4	158.8	60.8	69.0																		48	
8	447.6	121.2	76.7	109.0	423.0	131.8	72.5	97.0	397.4	143.8	68.1	86.0	381.6	151.6	65.4	80.0	365.4	160.0	62.6	73.0																		48	
9	460.4	122.4	78.9	115.0	435.2	133.0	74.6	103.0	409.0	145.0	70.1	91.0	392.6	152.8	67.3	84.0	376.0	161.4	64.5	77.0																		48	
10	472.8	123.4	81.1	121.0	447.0	134.2	76.6	108.0	420.0	146.2	72.0	96.0	403.2	154.0	69.1	89.0	386.2	162.6	66.2	81.0																		48	

- Q; Cooling Capacity in kW
- P; Total Power Absorbed in kW
- WFR; Water Flow Rate in m<sup>3</sup>/hr.
- Pd; Water Pressure Drop in kPa
- CWT; Chilled Water Temperature in °C (ΔT = 5°C)
- MAT; Maximum Ambient Temperature in °C
- NOTES:
  - Waterflow and pressure drop on heat exchangers calculated with 5°C of delta T
  - Interpolation between rating is permissible but extrapolation is not.

R-407C, 1-Circuit Units

Model: ACSC2005014C																																							
CWT	Ambient Temperature (°C)																														MAT								
	30					35					40					43					46					50						52							
	Q	P	WFR	Pd		Q	P	WFR	Pd		Q	P	WFR	Pd		Q	P	WFR	Pd		Q	P	WFR	Pd		Q	P	WFR	Pd			Q	P	WFR	Pd		Q	P	WFR
5	48.3	14.9	8.3	7.0	46.0	16.2	7.9	6.0	43.6	17.8	7.5	5.0	42.1	18.8	7.2	5.0	40.5	19.8	6.9	5.0	38.4	21.3	6.6	4.0												50			
6	50.1	15.0	8.6	7.0	47.7	16.3	8.2	7.0	45.2	17.8	7.7	6.0	43.7	18.8	7.5	6.0	42.1	19.9	7.2	5.0	39.9	21.4	6.8	5.0													50		
7	51.8	15.0	8.9	8.0	49.3	16.4	8.5	7.0	46.7	17.9	8.0	6.0	45.1	18.9	7.7	6.0	43.5	20.0	7.5	5.0	41.2	21.5	7.1	5.0													50		
8	53.6	15.1	9.2	8.0	51.1	16.4	8.8	7.0	48.4	18.0	8.3	7.0	46.8	19.0	8.0	6.0	45.1	20.1	7.7	6.0	42.8	21.6	7.3	5.0													50		
9	55.3	15.2	9.5	9.0	52.7	16.5	9.0	8.0	50.0	18.1	8.6	7.0	48.3	19.1	8.3	7.0	46.5	20.1	8.0	6.0	44.2	21.7	7.6	6.0													50		
10	56.8	15.2	9.7	9.0	54.2	16.6	9.3	8.0	51.4	18.1	8.8	7.0	49.6	19.1	8.5	7.0	47.9	20.2	8.2	7.0	45.4	21.8	7.8	6.0													50		

Model: ACSC2006014C																																							
CWT	Ambient Temperature (°C)																														MAT								
	30					35					40					43					46					50						52							
	Q	P	WFR	Pd		Q	P	WFR	Pd		Q	P	WFR	Pd		Q	P	WFR	Pd		Q	P	WFR	Pd		Q	P	WFR	Pd			Q	P	WFR	Pd		Q	P	WFR
5	60.0	17.4	10.3	3.0	57.0	19.1	9.8	3.0	53.7	21.0	9.2	3.0	51.6	22.3	8.8	2.0	49.5	23.7	8.5	2.0																		49	
6	61.1	17.4	10.5	3.0	58.1	19.1	10.0	3.0	54.8	21.1	9.4	3.0	52.7	22.4	9.0	2.0	50.6	23.8	8.7	2.0																		49	
7	62.3	17.5	10.7	3.0	59.2	19.2	10.1	3.0	55.9	21.2	9.6	3.0	53.9	22.5	9.2	3.0	51.7	23.9	8.9	2.0																		49	
8	64.4	17.6	11.0	4.0	61.3	19.3	10.5	3.0	57.9	21.3	9.9	3.0	55.8	22.6	9.6	3.0	53.6	24.0	9.2	3.0																		49	
9	66.4	17.7	11.4	4.0	63.2																																		

# Performance Data

## R-407C, 1- Circuit Units

Model: ACSC2009514C																													
Ambient Temperature (°C)																													
CWT	30				35				40				43				46				50				52				MAT
	Q	P	WFR	Pd	Q	P	WFR	Pd	Q	P	WFR	Pd	Q	P	WFR	Pd	Q	P	WFR	Pd	Q	P	WFR	Pd	Q	P	WFR	Pd	
5	94.9	29.2	16.3	12.0	90.0	32.3	15.4	11.0	84.7	35.7	14.5	10.0	81.4	38.0	14.0	9.0	77.9	40.4	13.4	9.0									47
6	98.1	29.5	16.8	13.0	93.0	32.5	15.9	12.0	87.6	35.9	15.0	11.0	84.2	38.2	14.4	10.0	80.7	40.7	13.8	9.0									47
7	101.0	29.7	17.3	14.0	95.8	32.7	16.4	13.0	90.3	36.2	15.5	11.0	86.8	38.5	14.9	10.0	83.2	41.0	14.3	10.0									47
8	104.5	29.9	17.9	15.0	99.2	33.0	17.0	13.0	93.5	36.5	16.0	12.0	89.9	38.8	15.4	11.0	86.2	41.3	14.8	10.0									47
9	107.7	30.1	18.5	16.0	102.2	33.2	17.5	14.0	96.4	36.7	16.5	13.0	92.7	39.1	15.9	12.0	88.9	41.6	15.2	11.0									47
10	110.5	30.3	18.9	16.0	104.9	33.4	18.0	15.0	98.9	37.0	17.0	13.0	95.2	39.3	16.3	12.0	91.3	41.8	15.7	11.0									47

Model: ACSC2011014C																													
Ambient Temperature (°C)																													
CWT	30				35				40				43				46				50				52				MAT
	Q	P	WFR	Pd	Q	P	WFR	Pd	Q	P	WFR	Pd	Q	P	WFR	Pd	Q	P	WFR	Pd	Q	P	WFR	Pd	Q	P	WFR	Pd	
5	106.4	32.3	18.2	15.0	101.0	35.7	17.3	14.0	95.3	39.6	16.3	13.0	91.8	42.2	15.7	12.0	88.2	45.1	15.1	11.0									48
6	109.9	32.6	18.8	16.0	104.4	36.0	17.9	15.0	98.6	39.9	16.9	13.0	95.0	42.6	16.3	12.0	91.2	45.4	15.6	12.0									48
7	113.2	32.8	19.4	17.0	107.5	36.3	18.4	16.0	101.6	40.2	17.4	14.0	97.9	42.9	16.8	13.0	94.1	45.7	16.1	12.0									48
8	117.0	33.1	20.1	18.0	111.2	36.6	19.1	17.0	105.1	40.6	18.0	15.0	101.3	43.2	17.4	14.0	97.5	46.1	16.7	13.0									48
9	120.6	33.3	20.7	19.0	114.6	36.9	19.6	17.0	108.4	40.9	18.6	16.0	104.5	43.6	17.9	15.0	100.5	46.4	17.2	14.0									48
10	123.8	33.6	21.2	20.0	117.7	37.1	20.2	18.0	111.3	41.2	19.1	16.0	107.3	43.8	18.4	15.0	103.3	46.7	17.7	14.0									48

Model: ACSC2011514C																													
Ambient Temperature (°C)																													
CWT	30				35				40				43				46				50				52				MAT
	Q	P	WFR	Pd	Q	P	WFR	Pd	Q	P	WFR	Pd	Q	P	WFR	Pd	Q	P	WFR	Pd	Q	P	WFR	Pd	Q	P	WFR	Pd	
5	115.7	36.6	19.8	18.0	109.4	40.5	18.8	16.0	102.9	45.0	17.6	14.0	98.9	48.1	17.0	13.0	94.7	51.4	16.2	12.0									47
6	119.5	36.9	20.5	19.0	113.1	40.8	19.4	17.0	106.4	45.4	18.2	15.0	102.3	48.4	17.5	14.0	98.1	51.7	16.8	13.0									47
7	123.1	37.2	21.1	20.0	116.5	41.1	20.0	18.0	109.6	45.7	18.8	16.0	105.4	48.7	18.1	15.0	101.1	52.1	17.3	14.0									47
8	127.2	37.5	21.8	21.0	120.5	41.5	20.7	19.0	113.5	46.1	19.5	17.0	109.2	49.1	18.7	16.0	104.8	52.5	18.0	15.0									47
9	131.2	37.8	22.5	22.0	124.2	41.8	21.3	20.0	117.0	46.4	20.1	18.0	112.6	49.5	19.3	17.0	108.1	52.9	18.5	16.0									47
10	134.7	38.1	23.1	24.0	127.6	42.1	21.9	21.0	120.3	46.8	20.6	19.0	115.7	49.9	19.8	18.0	111.1	53.2	19.0	16.0									47

Model: ACSC2014014C																													
Ambient Temperature (°C)																													
CWT	30				35				40				43				46				50				52				MAT
	Q	P	WFR	Pd	Q	P	WFR	Pd	Q	P	WFR	Pd	Q	P	WFR	Pd	Q	P	WFR	Pd	Q	P	WFR	Pd	Q	P	WFR	Pd	
5	138.7	41.3	23.8	14.0	131.0	45.5	22.5	12.0	123.1	50.3	21.1	11.0	118.2	53.5	20.3	10.0	113.3	57.0	19.4	9.0									48
6	143.9	41.7	24.7	15.0	135.9	45.8	23.3	13.0	127.8	50.6	21.9	12.0	122.8	53.9	21.1	11.0	117.8	57.4	20.2	10.0									48
7	148.5	42.0	25.5	15.0	140.3	46.2	24.1	14.0	131.9	51.0	22.6	12.0	126.8	54.2	21.7	12.0	121.6	57.7	20.8	11.0									48
8	153.2	42.3	26.3	16.0	144.9	46.5	24.8	15.0	136.3	51.3	23.4	13.0	131.1	54.6	22.5	12.0	125.7	58.1	21.5	11.0									48
9	157.7	42.7	27.0	17.0	149.1	46.8	25.6	15.0	140.3	51.7	24.1	14.0	135.0	54.9	23.1	13.0	129.5	58.4	22.2	12.0									48
10	161.7	42.9	27.7	18.0	152.9	47.1	26.2	16.0	144.0	52.0	24.7	14.0	138.5	55.2	23.7	13.0	132.9	58.7	22.8	12.0									48

Model: ACSC2015014C																													
Ambient Temperature (°C)																													
CWT	30				35				40				43				46				50				52				MAT
	Q	P	WFR	Pd	Q	P	WFR	Pd	Q	P	WFR	Pd	Q	P	WFR	Pd	Q	P	WFR	Pd	Q	P	WFR	Pd	Q	P	WFR	Pd	
5	149.9	45.9	25.7	16.0	141.7	50.7	24.3	14.0	133.0	56.1	22.8	13.0	127.5	59.7	21.9	12.0	121.8	63.6	20.9	11.0									47
6	155.5	46.4	26.7	17.0	147.0	51.1	25.2	15.0	138.1	56.5	23.7	14.0	132.5	60.2	22.7	13.0	126.7	64.1	21.7	12.0									47
7	160.5	46.7	27.5	18.0	151.8	51.5	26.0	16.0	142.6	57.0	24.4	14.0	136.9	60.6	23.5	13.0	130.9	64.5	22.4	12.0									47
8	165.6	47.1	28.4	19.0	156.7	51.9	26.9	17.0	147.3	57.4	25.3	15.0	141.5	61.0	24.3	14.0	135.4	65.0	23.2	13.0									47
9	170.4	47.5	29.2	20.0	161.3	52.3	27.7	18.0	151.7	57.8	26.0	16.0	145.7	61.5	25.0	15.0	139.5	65.4	23.9	14.0									47
10	174.8	47.8	30.0	21.0	165.5	52.6	28.4	19.0	155.7	58.2	26.7	17.0	149.6	61.8	25.6	16.0	143.2	65.8	24.5	14.0									47

- Q; Cooling Capacity in kW
- P; Total Power Absorbed in kW
- WFR; Water Flow Rate in m3/hr.
- Pd; Water Pressure Drop in kPa
- CWT; Chilled Water Temperature in °C ( $\Delta T = 5^\circ C$ )
- MAT; Maximum Ambient Temperature in °C
- NOTES:

- Waterflow and pressure drop on heat exchangers calculated with 5°C of delta T
- Interpolation between rating is permissible but extrapolation is not.

## R-407C, 1- Circuit Units

Model: ACSC2016514C																													
Ambient Temperature (°C)																													
CWT	30				35				40				43				46				50				52				MAT
	Q	P	WFR	Pd	Q	P	WFR	Pd	Q	P	WFR	Pd	Q	P	WFR	Pd	Q	P	WFR	Pd	Q	P	WFR	Pd	Q	P	WFR	Pd	
5	164.3	50.5	28.2	19.0	155.8	55.5	26.7	17.0	146.6	61.2	25.1	15.0	140.6	65.0	24.1	14.0	134.3	69.0	23.0	13.0									48
6	170.5	50.9	29.2	20.0	161.8	55.9	27.7	18.0	152.3	61.7	26.1	16.0	146.2	65.5	25.1	15.0	139.8	69.5	24.0	14.0									48
7	176.1	51.2	30.2	21.0	167.1	56.3	28.6	19.0	157.4	62.1	27.0	17.0	151.2	65.9	25.9	16.0	144.6	70.0	24.8	15.0									48
8	181.7	51.6	31.1	23.0	172.6	56.7	29.6	20.0	162.7	62.5	27.9	18.0	156.3	66.3	26.8	17.0	149.7	70.5	25.7	16.0									48
9	187.1	52.0	32.1	24.0	177.7	57.1	30.5	22.0	167.6	62.9	28.7	19.0	161.1	66.8	27.6	18.0	154.4	70.9	26.5	17.0									48
10	192.1	52.3	32.9	25.0	182.4	57.4	31.3	23.0	172.1	63.3	29.5	20.0	165.5	67.2	28.4	19.0	158.6	71.3	27.2	17.0									48

- Q; Cooling Capacity in kW
- P; Total Power Absorbed in kW
- WFR; Water Flow Rate in m3/hr.
- Pd; Water Pressure Drop in kPa
- CWT; Chilled Water Temperature in °C ( $\Delta T = 5^\circ C$ )
- MAT; Maximum Ambient Temperature in °C
- NOTES:

- Waterflow and pressure drop on heat exchangers calculated with 5°C of delta T
- Interpolation between rating is permissible but extrapolation is not.

# Performance Data

## R-407C, 2- Circuit Units

Model: ACSC4016524C																													
CWT	Ambient Temperature (°C)																										MAT		
	30				35				40				43				46				50				52				
	Q	P	WFR	Pd	Q	P	WFR	Pd	Q	P	WFR	Pd	Q	P	WFR	Pd	Q	P	WFR	Pd	Q	P	WFR	Pd	Q	P		WFR	Pd
5	162.4	45.8	27.8	22.0	154.0	50.2	26.4	19.0	144.8	55.2	24.8	17.0	139.0	58.6	23.8	16.0	133.2	62.0	22.8	15.0	124.8	67.2	21.4	13.0					50
6	168.4	46.0	28.9	23.0	159.6	50.4	27.4	21.0	150.4	55.4	25.8	19.0	144.4	58.8	24.8	17.0	138.4	62.4	23.7	16.0	130.0	67.6	22.3	14.0					50
7	173.6	46.2	29.8	24.0	164.8	50.6	28.3	22.0	155.2	55.8	26.6	20.0	149.2	59.0	25.6	18.0	143.0	62.6	24.5	17.0	134.2	67.8	23.0	15.0					50
8	180.0	46.6	30.9	26.0	170.8	51.0	29.3	24.0	161.0	56.0	27.6	21.0	154.8	59.4	26.5	20.0	148.4	63.0	25.4	18.0	139.6	68.2	23.9	16.0					50
9	185.6	46.8	31.8	27.0	176.4	51.2	30.2	25.0	166.2	56.4	28.5	22.0	160.0	59.6	27.4	21.0	153.4	63.2	26.3	19.0	144.4	68.6	24.8	17.0					50
10	190.8	47.0	32.7	29.0	181.2	51.4	31.1	26.0	170.8	56.6	29.3	23.0	164.4	60.0	28.2	22.0	157.6	63.6	27.0	20.0	148.4	68.8	25.4	18.0					50

Model: ACSC4017524C																													
CWT	Ambient Temperature (°C)																										MAT		
	30				35				40				43				46				50				52				
	Q	P	WFR	Pd	Q	P	WFR	Pd	Q	P	WFR	Pd	Q	P	WFR	Pd	Q	P	WFR	Pd	Q	P	WFR	Pd	Q	P		WFR	Pd
5	172.2	49.6	29.5	24.0	163.6	54.6	28.0	22.0	154.0	60.0	26.4	19.0	148.0	63.6	25.4	18.0	141.6	67.6	24.3	17.0	132.6	73.2	22.7	15.0					50
6	178.2	50.0	30.5	26.0	169.4	54.8	29.0	23.0	159.6	60.4	27.4	21.0	153.4	64.0	26.3	19.0	147.0	68.0	25.2	18.0	137.8	73.6	23.6	16.0					50
7	183.6	50.2	31.5	27.0	174.6	55.2	29.9	25.0	164.6	60.6	28.2	22.0	158.2	64.4	27.1	20.0	151.6	68.2	26.0	19.0	142.2	73.8	24.4	17.0					50
8	190.0	50.6	32.6	29.0	180.8	55.4	31.0	26.0	170.6	61.0	29.2	23.0	164.0	64.8	28.1	22.0	157.2	68.6	26.9	20.0	147.8	74.2	25.3	18.0					50
9	196.0	50.8	33.6	30.0	186.4	55.8	32.0	28.0	176.0	61.4	30.2	25.0	169.4	65.0	29.0	23.0	162.4	69.0	27.8	21.0	152.6	74.6	26.2	19.0					50
10	201.2	51.2	34.5	32.0	191.6	56.0	32.8	29.0	180.8	61.6	31.0	26.0	174.0	65.4	29.8	24.0	166.8	69.4	28.6	22.0	156.8	75.0	26.9	20.0					50

Model: ACSC4019524C																													
CWT	Ambient Temperature (°C)																										MAT		
	30				35				40				43				46				50				52				
	Q	P	WFR	Pd	Q	P	WFR	Pd	Q	P	WFR	Pd	Q	P	WFR	Pd	Q	P	WFR	Pd	Q	P	WFR	Pd	Q	P		WFR	Pd
5	193.8	57.6	33.2	29.0	183.8	63.4	31.5	27.0	173.2	70.0	29.7	24.0	166.6	74.6	28.6	22.0	159.6	79.4	27.4	20.0									48
6	200.4	58.0	34.4	31.0	190.2	63.8	32.6	28.0	179.4	70.6	30.8	25.0	172.6	75.0	29.6	24.0	165.6	79.8	28.4	22.0									48
7	206.4	58.4	35.4	33.0	196.0	64.2	33.6	30.0	185.0	71.0	31.7	27.0	178.0	75.6	30.5	25.0	170.8	80.4	29.3	23.0									48
8	213.6	58.8	36.6	35.0	202.8	64.8	34.8	32.0	191.4	71.6	32.8	28.0	184.2	76.0	31.6	26.0	176.8	81.0	30.3	24.0									48
9	220.0	59.2	37.7	37.0	209.0	65.2	35.8	33.0	197.2	72.0	33.8	30.0	189.8	76.6	32.5	28.0	182.2	81.4	31.2	26.0									48
10	225.6	59.6	38.7	38.0	214.2	65.6	36.7	35.0	202.2	72.4	34.7	31.0	194.6	77.0	33.4	29.0	186.8	81.8	32.0	27.0									48

Model: ACSC4023024C																													
CWT	Ambient Temperature (°C)																										MAT		
	30				35				40				43				46				50				52				
	Q	P	WFR	Pd	Q	P	WFR	Pd	Q	P	WFR	Pd	Q	P	WFR	Pd	Q	P	WFR	Pd	Q	P	WFR	Pd	Q	P		WFR	Pd
5	222.2	66.4	38.1	33.0	210.6	73.4	36.1	30.0	198.4	81.4	34.0	26.0	191.0	86.8	32.7	25.0	183.2	92.6	31.4	23.0									46
6	232.4	67.2	39.8	35.0	220.4	74.2	37.8	32.0	207.8	82.4	35.6	29.0	200.0	87.8	34.3	27.0	192.0	93.6	32.9	25.0									46
7	240.8	67.8	41.3	38.0	228.2	75.0	39.1	34.0	215.2	83.2	36.9	31.0	207.2	88.6	35.5	29.0	198.8	94.4	34.1	26.0									46
8	248.8	68.4	42.7	40.0	236.0	75.6	40.5	36.0	222.8	83.8	38.2	32.0	214.4	89.4	36.8	30.0	206.0	95.2	35.3	28.0									46
9	256.4	69.0	44.0	42.0	243.2	76.4	41.7	38.0	229.4	84.6	39.3	34.0	221.0	90.0	37.9	32.0	212.2	96.0	36.4	29.0									46
10	262.8	69.6	45.1	44.0	249.4	77.0	42.8	40.0	235.2	85.2	40.3	36.0	226.4	90.8	38.8	33.0	217.6	96.6	37.3	31.0									46

Model: ACSC4026024C																													
CWT	Ambient Temperature (°C)																										MAT		
	30				35				40				43				46				50				52				
	Q	P	WFR	Pd	Q	P	WFR	Pd	Q	P	WFR	Pd	Q	P	WFR	Pd	Q	P	WFR	Pd	Q	P	WFR	Pd	Q	P		WFR	Pd
5	257.6	75.8	44.2	15.0	243.8	83.4	41.8	14.0	229.4	92.0	39.3	12.0	220.4	97.8	37.8	11.0	211.4	104.2	36.2	11.0									48
6	266.6	76.4	45.7	16.0	252.2	84.0	43.2	15.0	237.6	92.8	40.7	13.0	228.4	98.6	39.2	12.0	219.2	104.8	37.6	11.0									48
7	274.6	77.0	47.1	17.0	259.8	84.6	44.5	16.0	244.8	93.4	42.0	14.0	235.4	99.2	40.4	13.0	226.0	105.4	38.7	12.0									48
8	284.0	77.6	48.7	18.0	269.0	85.2	46.1	16.0	253.4	94.0	43.4	15.0	243.8	99.8	41.8	14.0	234.2	106.2	40.1	13.0									48
9	292.6	78.2	50.2	19.0	277.2	86.0	47.5	17.0	261.2	94.6	44.8	15.0	251.4	100.6	43.1	14.0	241.4	107.0	41.4	13.0									48
10	300.4	78.8	51.5	20.0	284.6	86.4	48.8	18.0	268.2	95.2	46.0	16.0	258.0	101.2	44.2	15.0	247.8	107.6	42.5	14.0									48

- Q; Cooling Capacity in kW
- P; Total Power Absorbed in kW
- WFR; Water Flow Rate in m3/hr.
- Pd; Water Pressure Drop in kPa
- CWT; Chilled Water Temperature in °C (ΔT = 5°C)
- MAT; Maximum Ambient Temperature in °C

NOTES:  
 I. Waterflow and pressure drop on heat exchangers calculated with 5°C of delta T  
 II. Interpolation between rating is permissible but extrapolation is not.

## R-407C, 2- Circuit Units

Model: ACSC4028024C																													
CWT	Ambient Temperature (°C)																										MAT		
	30				35				40				43				46				50				52				
	Q	P	WFR	Pd	Q	P	WFR	Pd	Q	P	WFR	Pd	Q	P	WFR	Pd	Q	P	WFR	Pd	Q	P	WFR	Pd	Q	P		WFR	Pd
5	278.6	84.4	47.8	18.0	262.8	92.8	45.1	16.0	246.6	102.8	42.3	14.0	236.6	109.4	40.6	13.0	226.6	116.6	38.8	12.0									47
6	288.2	85.0	49.4	19.0	272.0	93.6	46.6	17.0	255.4	103.4	43.8	15.0	245.2	110.0	42.0	14.0	234.8	117.2	40.3	13.0									47
7	297.0	85.8	50.9	20.0	280.4	94.2	48.1	18.0	263.2	104.2	45.1	16.0	252.8	110.8	43.3	15.0	242.2	118.0	41.5	14.0									47
8	307.2	86.4	52.7	21.0	290.0	95.0	49.7	19.0	272.4	105.0	46.7	17.0	261.8	111.6	44.9	16.0	250.8	118.8	43.0	14.0									47
9	316.6	87.2	54.3	22.0	299.0	95.8	51.3	20.0	281.0	105.8	48.2	18.0	270.0	112.4	46.3	16.0	258.8	119.6	44.4	15.0									47
10	325.0	87.8	55.7	23.0	307.0	96.4	52.6	21.0	288.6	106.4	49.5	19.0	277.2	113.0	47.5	17.0	265.8	120.2	45.6	16.0									47

Model: ACSC4031024C																													
CWT	Ambient Temperature (°C)																										MAT		
	30				35				40				43				46				50				52				
	Q	P	WFR	Pd	Q	P	WFR	Pd	Q	P	WFR	Pd	Q	P	WFR	Pd	Q	P	WFR	Pd	Q	P	WFR	Pd	Q	P		WFR	Pd
5	308.2	91.6	52.8	37.0	291.2	101.0	49.9	34.0	273.6	111.6	46.9	30.0	262.4	118.8	45.0	28.0	250.8	126.4	43.0	25.0									47
6	318.6	92.4	54.6	40.0	301.4	101.8	51.7	36.0	283.2	112.4	48.5	32.0	271.8	119.6	46.6	29.0	260.0	127.4	44.6	27.0									47
7	328.4	93.0	56.3	42.0	310.6	102.4	53.2	38.0	292.0	113.2	50.1	34.0	280.4	120.4															

Water Side Evaporator Pressure Drop Curves

R410A

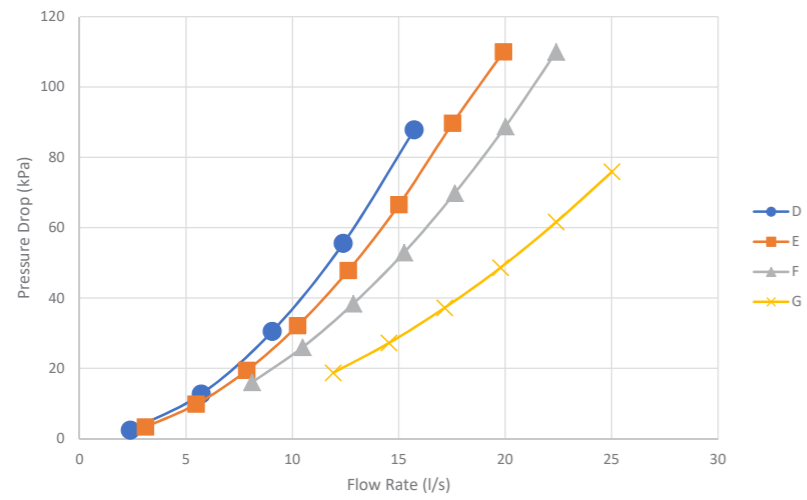
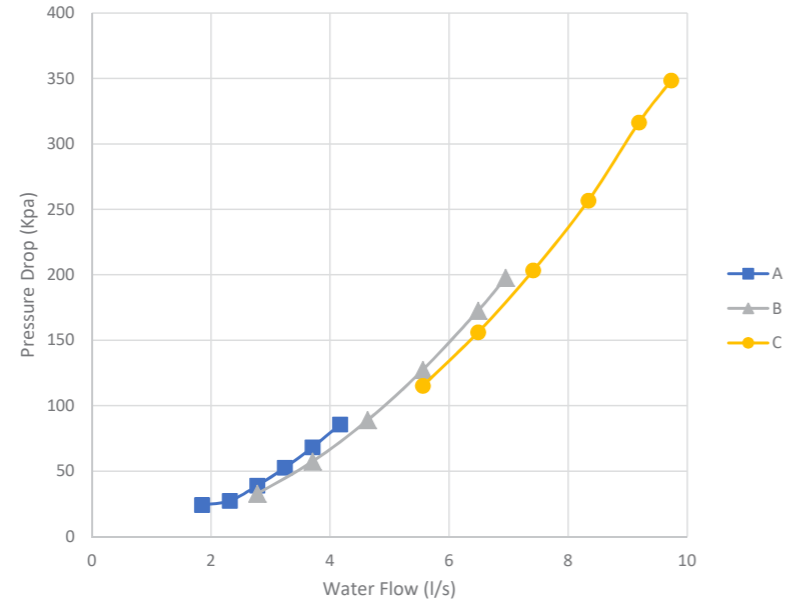

A	ACSC2005514A, ACSC2006014A, ACSC2006514A, ACSC2007514A
B	ACSC2009014A, ACSC2010514A, ACSC2011514A, ACSC2013014A, ACSC2014514A
C	ACSC2016514A, ACSC2018514A, ACSC2020514A
D	ACSC4017024A, ACSC4018024A
E	ACSC4020524A
F	ACSC4023024A, ACSC4026024A, ACSC4028024A
G	ACSC4033024A, ACSC4037024A, ACSC4041024A

R407C

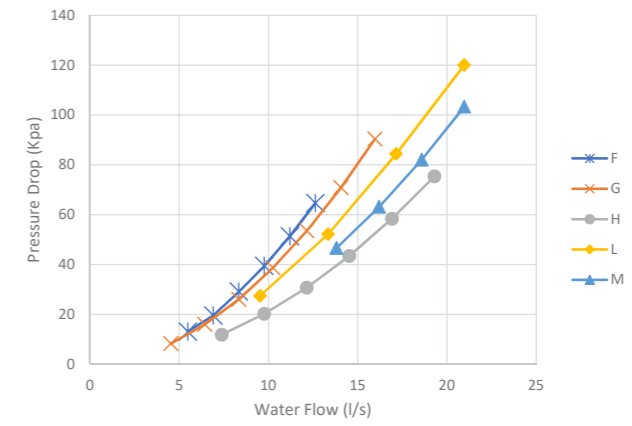
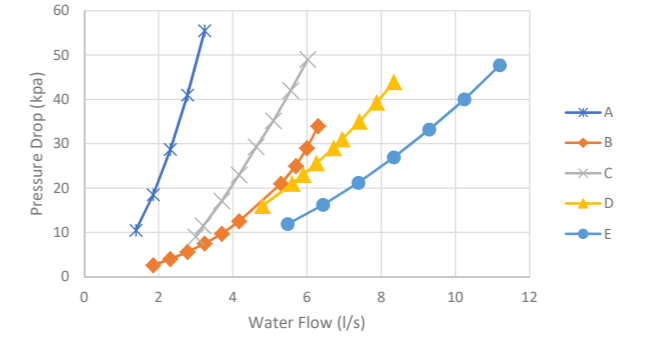

A	ACSC2005014C
B	ACSC2006014C, ACSC2006514C
C	ACSC2007014C, ACSC2008514C, ACSC2009514C, ACSC2011014C, ACSC2011514C
D	ACSC2014014C, ACSC2015014C, ACSC2016514C
E	ACSC4016524C, ACSC4017524C
F	ACSC4019524C
G	ACSC4023024C
H	ACSC4026024C, ACSC4028024C
L	ACSC4031024C
M	ACSC4034024C



**Ambient Limitations**

Arvand air-cooled chillers are designed for year-round operation over a range of ambient temperatures. All units could be operating in condition inside envelope chart below. With the low ambient options, these units will operate in lower ambient temperature. Our customers can always order a unit out of envelope condition, for this, contact our specialist in Arvand company.

**Water Flow Limits**

The minimum and maximum water flow rates are given in the General Data tables. Evaporator flow rates below the tabulated values will result in laminar flow causing freeze up problems, scaling, stratification and poor control. Flow rates exceeding those listed may result in excessive tube erosion.

Note: Flow rates in General Data tables are for water only. They do not include glycol.

**Leaving Water Temperature Limits**

Arvand air-cooled ACS chillers have the standard leaving solution temperature range 5 to 15°C. Since water supply temperature setpoints less than 4.4°C result in suction temperatures at or below the freezing point of water, a glycol solution is required for all low temperature machines.

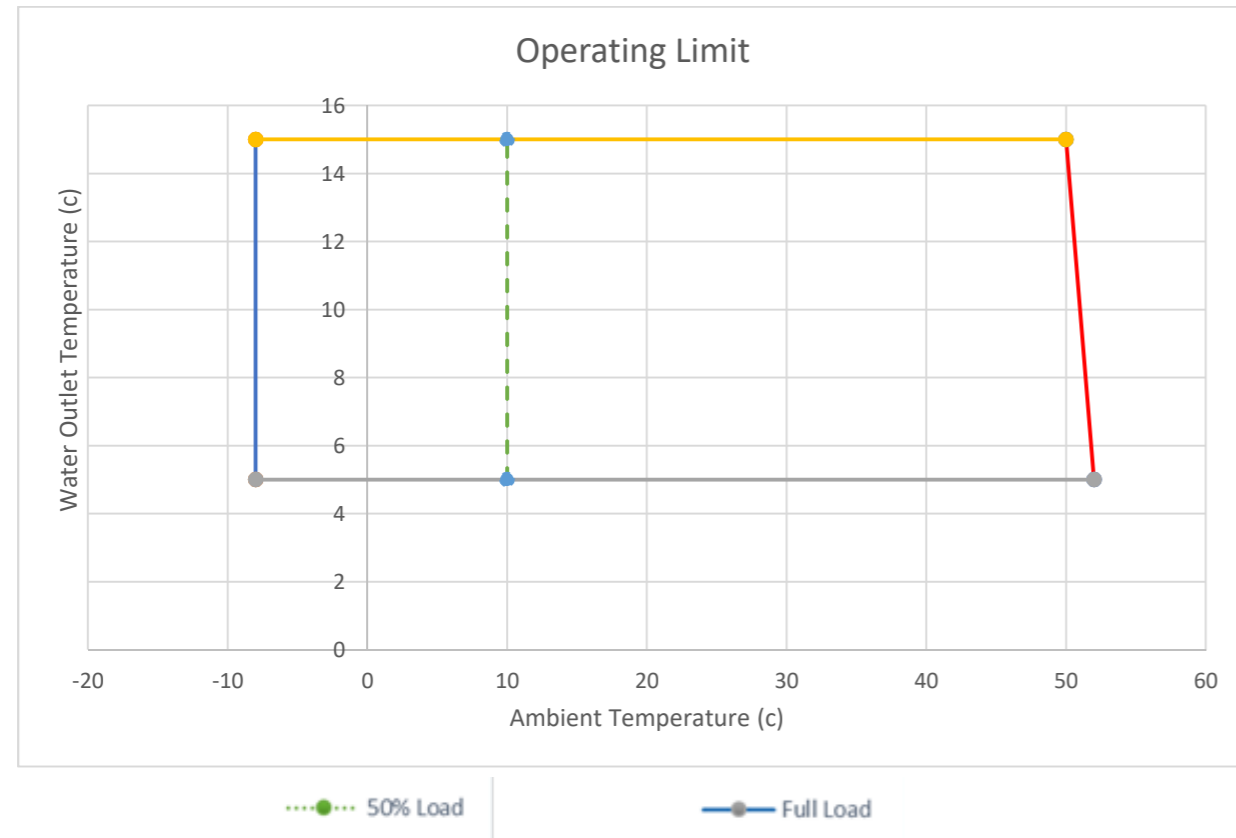

Model	Rated Voltage <sup>2</sup>	Compressor Quantity	Fan Quantity	Fan Power (kW)	OLA (A) <sup>3</sup>	FLA (A) <sup>4</sup>	LRA (A) <sup>5</sup>	MOP (kW) <sup>6</sup>
ACSC2005514A	400/3/50	2	3	1.1	26	42	134.1	23
ACSC2006014A	400/3/50	2	3	1.1	30.5	46	143.1	26.2
ACSC2006514A	400/3/50	2	3	1.1	31.1	50	145.1	28.5
ACSC2007514A	400/3/50	2	3	1.1	34.9	62	173.1	34.5
ACSC2009014A	400/3/50	2	2	1.9	48.4	78	218.6	41.1
ACSC2010514A	400/3/50	2	2	1.9	51.3	85	269.6	47.6
ACSC2011514A	400/3/50	2	2	1.9	52.9	92	276.6	54.2
ACSC2013014A	400/3/50	2	2	1.9	61.7	102	323.6	59.4
ACSC2014514A	400/3/50	2	3	1.9	71.9	116	338.4	66.4
ACSC2016514A	400/3/50	2	3	1.9	82.4	127	376.4	73
ACSC2018514A	400/3/50	2	4	1.9	94.2	142	392.2	81.5
ACSC2020514A	400/3/50	2	4	1.9	106.2	162	562.2	93.9
ACSC4017024A	400/3/50	4	4	1.9	87.9	79	284.2	76.1
ACSC4018024A	400/3/50	4	4	1.9	95.6	86	298.2	82.1
ACSC4020524A	400/3/50	4	4	1.9	101.1	93	356.2	95.3
ACSC4023024A	400/3/50	4	4	1.9	106.8	100	370.2	108.4
ACSC4026024A	400/3/50	4	6	1.9	128.1	118	436.8	122.5
ACSC4028024A	400/3/50	4	6	1.9	145.2	128	456.8	132.9
ACSC4033024A	400/3/50	4	6	1.9	163.7	139	505.8	146
ACSC4037024A	400/3/50	4	8	1.9	188.1	158	537.4	162.9
ACSC4041024A	400/3/50	4	8	1.9	211.8	178	727.4	187.8

1. All measures are calculated at 35 °C ambient temperature and entering/leaving water temperature 12/7 °C
2. Voltage Utilization Range: +/- 5% of rated voltage. Rated voltage (use range): 400 volt (380-420)
3. OLA - Unit Operating Load Amps
4. FLA - Unit Full load Amps
5. ICF - Instantaneous Maximum Starting amps (any point in starting sequence where sum of LRA for 'starting compressor is maximum).
6. MOP - Unit Maximum Operating Power

Model	Rated Voltage <sup>2</sup>	Compressor Quantity	Fan Quantity	Fan Power (kW)	OLA (A) <sup>3</sup>	FLA (A) <sup>4</sup>	LRA (A) <sup>5</sup>	MOP (kW) <sup>6</sup>
ACSC2005014C	400/3/50	2	3	1.1	24.9	42	134.1	23
ACSC2006014C	400/3/50	2	3	1.1	28.7	46	143.1	26.2
ACSC2006514C	400/3/50	2	3	1.1	31.7	50	145.1	28.5
ACSC2007014C	400/3/50	2	3	1.1	36.7	62	173.1	34.5
ACSC2008514C	400/3/50	2	2	1.9	54.1	78	218.6	41.1
ACSC2009514C	400/3/50	2	2	1.9	56.7	85	269.6	47.6
ACSC2011014C	400/3/50	2	2	1.9	58.2	92	276.6	54.2
ACSC2011514C	400/3/50	2	2	1.9	66.1	102	323.6	59.4
ACSC2014014C	400/3/50	2	3	1.9	76.3	116	338.4	66.4
ACSC2015014C	400/3/50	2	3	1.9	83.8	127	376.4	73
ACSC2016514C	400/3/50	2	4	1.9	92.8	142	392.2	81.5
ACSC4016524C	400/3/50	4	4	1.9	95.4	79	284.2	76.1
ACSC4017524C	400/3/50	4	4	1.9	107.4	86	298.2	82.1
ACSC4019524C	400/3/50	4	4	1.9	112.2	93	356.2	95.3
ACSC4023024C	400/3/50	4	4	1.9	118.5	100	370.2	108.4
ACSC4026024C	400/3/50	4	6	1.9	138.8	118	436.8	122.5
ACSC4028024C	400/3/50	4	6	1.9	154.6	128	456.8	132.9
ACSC4031024C	400/3/50	4	6	1.9	167.3	139	505.8	146
ACSC4034024C	400/3/50	4	8	1.9	186.4	158	537.4	162.9

1. All measures are calculated at 35 °C ambient temperature and entering/leaving water temperature 12/7 °C
2. Voltage Utilization Range: +/- 5% of rated voltage. Rated voltage (use range): 400 volt (380-420)
3. OLA - Unit Operating Load Amps
4. FLA - Unit Full load Amps
5. ICF - Instantaneous Maximum Starting amps (any point in starting sequence where sum of LRA for 'starting compressor is maximum).
6. MOP - Unit Maximum Operating Power

#### • Electronic control

The units are supplied with the new Pre-Configurable Controller-based electronic control and management system ensuring the following functions:

- Management of the operation of compressors:
  - Power on/off
  - Compressor rotation
  - Stop for high pressure or high compressor pressure ratio (integrated inside the curve of compressor operating limits this means Compressors Envelope Control).
- Chilled water temperature regulation (control on leaving water temperature (LWT) of the evaporator or on inlet water temperature (RWT) as optional).
- Evaporator antifreeze protection.
- Management of high- and low-pressure alarms.
- Management of the compressors on over Load.
- Management of the compressors on the all circuits.
- Management of external interlocks Via Dry Contacts or Modbus protocol.
- Management of the remote control:
  - Read all of sensors information
  - Alarm signals
  - Managements of all Control Parameters as LWT set point and all other control parameters
- Remote signaling, by free contacts:
  - Unit status.
  - General alarm
- Chilled or cooled water Flow switch inter lock.

The unit controller can also clearly show all control parameters of the machine on the LCD (HMI as an Option), such as:

- Display of the temperature set point at evaporator inlet or outlet.
- Display of the electronic expansion valve super heat Set Point (if installed).
- Display of the circuit 1 and circuit 2 discharge pressure and suction pressure.
- Display of opening steps of EEV (if installed).
- Display of speed control signal of fans.
- Display of the various alarm and operation status.
- Low/High pressure indicator.
- Low/High prevent.
- Water flow switch signal.
- Control of the compressor operating hours.
- Compressors in operation.
- Pump in operation
- Thermal protection of compressors.
- Thermal protection of fans.
- Faulty sensors.

#### • Control and safety devices

Each unit is fitted with the following devices:

##### Safety:

- Power disconnect switch with an emergency stop function.
- Phase Control (Sequence and Range) in Electric Power
- HP switches set to 28 bar for R407C model and 42 bar for R410A models, manual reset to be reinitialized from controller.
- Safety valve on the discharge line (HP side) set to 31 bar for R407C Models and 44 bar for R410A models.
- LP switches (one for each circuit) set to 2 bar for R407C models and 2.7 bar for R410A models, Auto reset to be reinitialized from controller by a logical rule inside the controller and after this limit stop the compressors
- Antifreeze System, set point in +4 Degree. (for Air Conditioning Applications)
- Discharge gas temperature protection, on the discharge line of each compressor.

General

The units are to be completely factory assembled and wired in a single package complete with tandem scroll compressors, evaporator, condenser, starting control with safety and operating controls. The unit shall be given a complete factory operating and control sequence test under load conditions and shall be shipped with full operating charge of refrigerant and full oil charge.

Work Included

Provide complete electrically or micro controlled air-cooled chiller utilizing tandem scroll compressor sets suitable for outdoor installation.

Delivery and Handling

The unit shall be delivered to the job site completely assembled and charged with refrigerant and oil by the manufacturer.

Maintenance

Maintenance of the chillers shall be the responsibility of the owner and performed in accordance with the manufacturer's instructions.

Construction

The unit shall be designed for maximum corrosion protection being of heavy gauge, galvanized steel construction with baked on powder coating.

Condenser

The condenser coil shall be constructed of copper tubes and die-formed aluminum V-Waffle fins having self-spacing collars. Fins shall be mechanically bonded to the tubes. Integral sub-cooling circuits shall be incorporated into the coil.

Fans

The fans shall be heavy duty, aluminum blade, direct drive propeller type. Motors shall be three phase type with internal overloads. Fan blades shall be statically and dynamically balanced.

Compressor

The compressors shall be Tandem Scroll with suction and discharge manifold, with oil or gas equalization provided. All compressors shall be direct drive. The compressors shall be fitted with a crankcase heater, and oil sight glass.

Evaporator

(Two compressors) (Four compressors) shall be used with a direct expansion evaporator. Insulate evaporator and other cold surfaces as required to prevent condensation at ambient conditions.

Refrigerant Circuit

(Two compressors) (Four compressors) shall be used with a direct expansion evaporator. Insulate evaporator and other cold surfaces as required to prevent condensation at ambient conditions. Each refrigerant circuit shall include expansion valve, sight glass, moisture indicator, solenoid valve, replaceable core filter-drier, liquid line shut off valves, and charging port.

Unit Mounted Main Disconnect Switch

MCCB switch shall be furnished to isolate unit main incoming power supply for servicing.

IP54 Control Panel

Control panel with IP54 rating shall be supplied for harsh working environment.

Control and safety devices

Each unit is fitted with the following devices:

Safety:

- Power disconnect switch with an emergency stop function.
- Phase Control (Sequence and Range) in Electric Power
- Safety valve on the discharge line (HP side).
- HP switches, manual reset to be reinitialized from controller.
- Antifreeze protection system, set point in +4 Degree. (for Air Conditioning Applications)
- Discharge gas pressure protection, on the discharge line of each compressor

For the selection of a unit use the performance table and the data tables relative to each unit.

For a correct chiller selection, it is also necessary:

1. Observe the functioning limits as pointed out in the chart "Operating Limits"
2. verify that the cool water flow is between minimum and maximum values of water flow which are tabled in the "Hydraulic Data" section; a very low flow can cause laminar flow and thus danger of ice formation and poor unit control; a very high flow can cause great pressure drops and the possibility of tube failure inside the evaporator
3. For working temperatures under 5 °C outlet water and 0 °C external air temperature it is necessary to add ethylene glycol or any other antifreeze liquids. Consult the table A.1 "SOLUTIONS OF WATER AND ETHYLENE GLYCOL" to determine the necessary quantity of ethylene glycol, the reduction of cooling capacity, the increase of power absorbed by the compressors, and the increase of evaporator pressure drop occur due to the presence of the ethylene glycol
4. If the machine is to be installed at an altitude higher than 500 meters, you must calculate the cooling capacity reduction and the increase of power absorbed by the compressor through the coefficients pointed out in the table A.2 "CONDENSER CORRECTION FACTORS"
5. When the difference in temperature between water inlet and outlet is different from 5 °C, the cooling capacity and the absorbed power must be connected using the table A.3 "CORRECTION FACTORS ΔT≠5 °C".
6. If the Entering water temperature (EWT) requirement is greater than 20 C, a mixing loop is required.
7. A high cooler pressure drop can be expected when the cooler delta-T is low. A mixing loop can help to alleviate this situation.
8. A low cooler pressure drop can be expected when cooler delta-T is high.

For instance, selecting a proper unit with the following assumption will be described in 9 steps:

Assumptions:

- Needed capacity = 200 kilowatt at ambient temperature 46 °C.
- Altitude of site is 2000 m.
- Ambient temperature may reduce down to -5°C.
- Inlet and outlet evaporator brine temperatures are 12°C and 7°C.

Step 1:

Extract Kc1, Kp1, Kdp1 and KFWE1 from table A.1 in Appendix.

In this case the freezing temperature must be lower than -5°C, so with adding 20% Ethylene Glycol by weight to Water the freezing point will be -8.7°C and refer to table A.1, Kc1=0.99, Kp1=0.99, Kdp1=1.05 and KFWE1=1.06.

Step 2:

Altitude of site is 2000 m. Refer to table A.2; Kc2 and Kp2 will be 0.98 and 1.04 in respect.

Step 3:

Since ΔT=12-7=5; Kc3 and Kp3 from table A.3 "CORRECTION FACTORS ΔT≠5 °C" are equal to 1.

Step 4:

According to the following equations calculate unit capacity and unit absorbed power in standard condition.

$$Q_{Actual} = Kc1 * Kc2 * Kc3 * Kc4 * Q_{Standard} \text{ (Equation 1)}$$

$$P_{Actual} = Kp1 * Kp2 * Kp3 * Kp4 * P_{Standard} \text{ (Equation 2)}$$

$$200 = 0.99 * 0.98 * 1 * 1 * Q_{Standard} \text{ then } Q_{Standard} = 200 / 0.97; Q_{Standard} = 206 \text{ kW.}$$

Acceptable deviation from capacity is 5%, so required unit has to be between 196 kW and 216 kW (196 kW < unit capacity < 216 kW).

Step 5:

Ambient temperature in actual full load is 46°C, so refer to "Performance Data" tables to select proper model. Because of this, kc4 and kp4 should consider equal to 1.

Step 6:

Refer to Performance table, ACSC4023024A unit capacity is 197.4 kW.

So, capacity in actual is equal to:

$$Q_{Actual} = Kc1 * Kc2 * kc3 * kc4 * Q_{Standard} = 0.99 * 0.98 * 1 * 1 * 197.4 = 191.5 \text{ kW}$$

Step 7:

Unit total absorbed power is 83.4 kW. Calculate new absorbed power from Equation 2.

$$P_{Actual} = 0.99 * 1.04 * 1 * 1 * 83.4 \text{ so } P_{Actual} = 85.87 \text{ kW}$$

Step 8:

Standard model Water Flow Rate will be calculated by Equation 3.

New Water Flow Rate = KFWE1 \* Standard Water Flow Rate (Equation 3)

Standard Water Flow Rate = 191.5/21 (l/s) = 9.12 (l/s)

New Water Flow Rate = 1.06 \* 9.12 = 9.67 (l/s)

For Convert l/s to m3/hr., multiple 3.6 to 9.67, so Water Flow Rate equal to 34.8 (m3/hr.)

Step 9:

For Calculating Cooler Pressure drop, use Equation 4.

New Pressure Drop = Kdp1 \* Standard Pressure Drop (use performance data table.)

New Pressure Drop = 1.05 \* 26 = 27.3 kPa.

Table A.1 SOLUTIONS OF WATER AND ETHYLENE GLYCOL

SOLUTION OF WATER AND ETHYLENE GLYCOL		% Ethylene Glycol by Weight					
		0	10	20	30	40	50
Freezing Temperature	°C	0	-3.7	-8.7	-15.3	-23.5	-35.6
Cooling Capacity Correction Factor	Kc1	1	0.99	0.99	0.98	0.97	0.96
Absorbed Power Correction Factor	Kp1	1	1	0.99	0.99	0.98	0.98
Pressure Drop Correction Factor	Kdp1	1	1.02	1.05	1.07	1.1	1.13
Water Flow Correction Factor	KFWE1	1	1.03	1.06	1.09	1.12	1.15

Table A.2 CONDENSER CORRECTION FACTORS

CONDENSER CORRECTION FACTORS		Altitude (m)					
		0	500	1000	1500	2000	2500
Cooling Capacity Correction Factor	Kc2	1	0.99	0.99	0.98	0.98	0.97
Absorbed Power Correction factor	Kp2	1	1.01	1.02	1.03	1.04	1.05
Reduction of the Maximum Ambient Air Temperature	Kt2(°C)	0	0.6	1.15	1.75	2.3	2.9

Table A.3 CORRECTION FACTORS ΔT ≠ 5 °C

CORRECTION FACTORS ΔT ≠ 5 °C		ΔT						
		4	5	6	7	8	9	10
Cooling Capacity Correction Factor	Kc3	0.99	1	1.01	1.02	1.02	1.03	1.04
Absorbed Power Correction factor	Kp3	1	1	1	1.01	1.01	1.02	1.02

Table A.4 CORRECTION FACTORS FOR AMBIENT TEMPERATURE

CORRECTION FACTORS FOR AMBIENT TEMPERATURE		Ambient Temperature (°C)									
		15	20	25	30	35	40	43	46	50	52
Cooling Capacity Correction Factor	Kc4	1.21	1.17	1.11	1.06	1.00	0.94	0.90	0.86	0.81	0.79
Absorbed Power Correction factor	Kp4	0.73	0.79	0.85	0.92	1.00	1.09	1.15	1.22	1.31	1.36



[www.arvandcorp.com](http://www.arvandcorp.com)

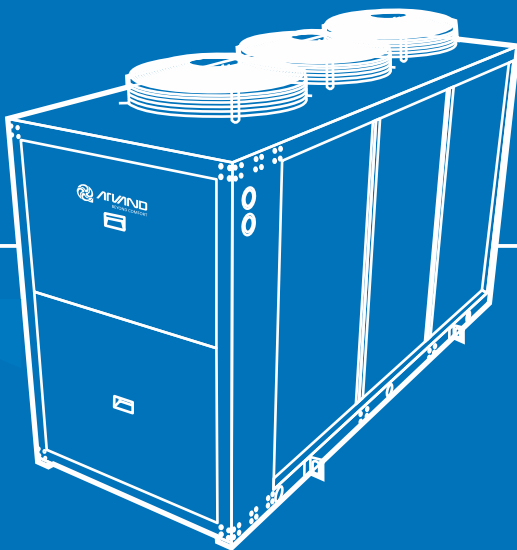

ARVAND



[www.arvandcorp.com](http://www.arvandcorp.com)

"ARVAND Co. reserves the right to revise and make changes in design and construction of any product at any time without notice."