

Air Cooled Screw Chiller

STURDY SERIES

CT-02-34-01

2022

Content

6	Introduction
7	Nomenclature
8	Features and Advantages
9	Application Considerations
11	Components
13	Options & Accessories
13	Physical and Technical Data
29	Dimensions and Clearances
69	Performance Data
97	Hydraulic Data
100	Operating Limits
102	Electrical Data
106	Control
108	Engineering Guide Specifications
110	Selecting Procedure
112	Appendix



AIR COOLED SCREW CHILLER
STURDY SERIES

چیلر هوا خنک

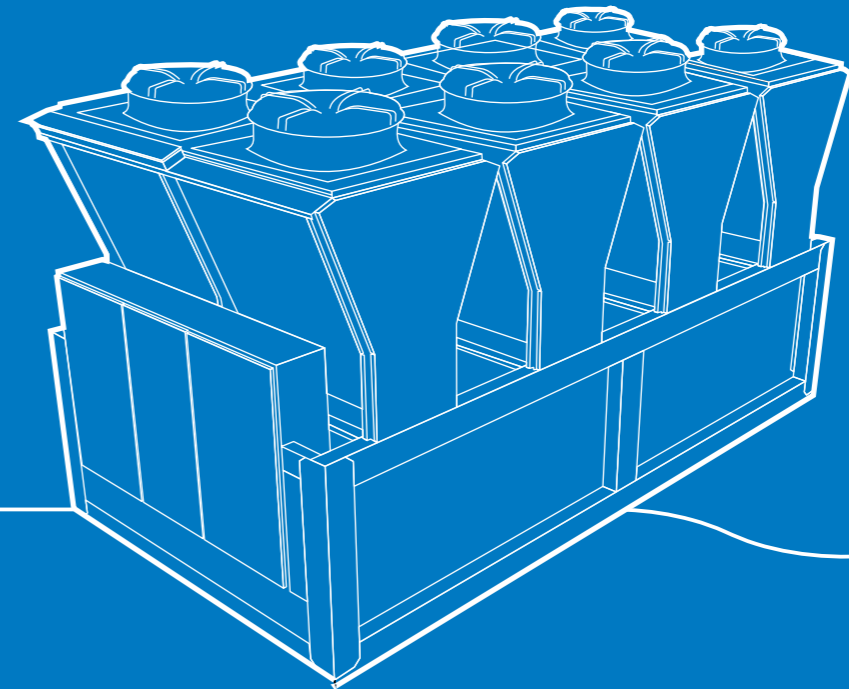

INTRODUCTION

Arvand ACW chillers are manufactured to the highest design and construction standards to ensure high performance, reliability and adaptability to all types of air conditioning installations. Units are compact and highly configurable, built to fit different types of plants so to meet the needs of highly qualified engineers.

Units are water chillers condensed in air with axial fans suitable for outdoor installation, the structure and panels are robust, made of galvanized and painted steel, all fasteners are made of stainless steel or galvanized steel, the frame containing the electrical equipment and all the components exposed to weather have a minimum IP54 degree of protection. This series is composed of 60 models with standard noise level with nominal cooling capacity from 100 to 1540 kW and 60 models with low noise level with nominal capacity from 100 to 1395 kw.

The units produce cold water from 5 to 10°C and as standard they are equipped with continuous adjustment of axial fans rotating speed in order to allow the units to operate with low outdoor temperature in cooling mode as well as to reduce noise emissions.

All the units are equipped with 1, 2 or 3 screw compressors arranged in 1, 2 or 3 circuit operating with environmental friendly gas R134a.

The high efficient DX evaporator is shell and tube type heat exchanger completely insulated.

The Condenser coil heat exchanger made of V-Waffles coated aluminum or copper fins (upon request) and copper tubes. axial fans with profiled blades to contain noise with thermal protection built-in and electrical control panel equipped with control system to manage the main functions.

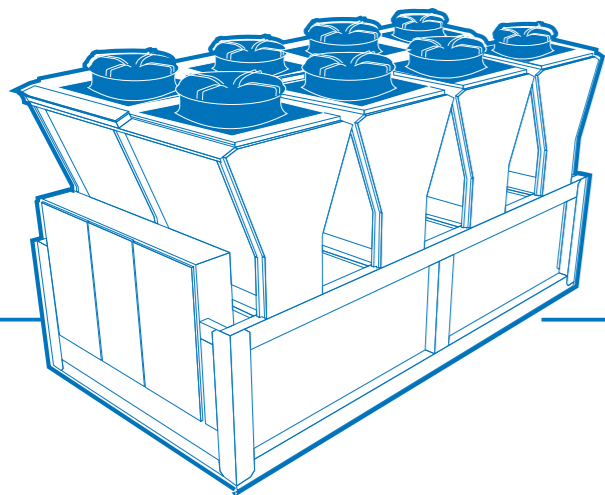

NOMENCLATURE

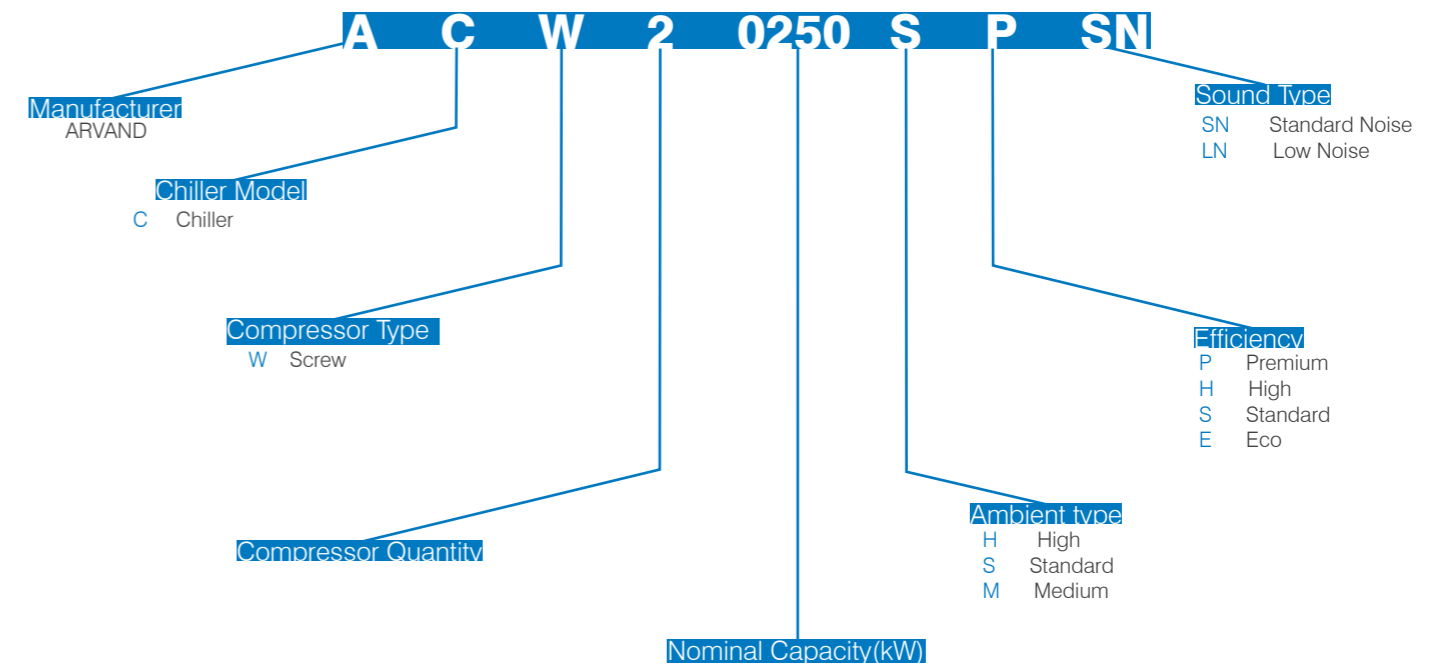

Features and Advantages

The ACW units are of the most affordable air-cooled chillers to operate and maintain. The chiller offers full load EER (Energy Efficiency Ratio) up to 3.5. The use of high efficiency compressors and heat exchangers with innovative design have made ACW units high efficient in the most severe weather conditions.

Standard Ambient Temperature Version

This version of ACW units is designed for mild climates and have the lowest price between all units. Standard Ambient version units have the ability of operating in full load mode in the ambient temperature up to 46 °C. These versions of chillers are the best choice for the application that need to operate chiller in year-round and the unit has to work in temperature down to -20 °C (receiver have to install).

High Ambient Temperature Version

This version of ACW units is designed to work in high ambient climates and also have the ability of operating in year-round applications. High Ambient version units have the ability of operating in full load mode in the ambient temperature up to 50 °C. This version of chillers is the best choice for hot and tropical climates and regions that the temperature difference between day and night is high.

Low Noise Version

This version of ACW units is designed for sound sensitive applications. With reduction in fan speed, air flow rate on condenser coils will decrease, so the maximum ambient temperature in which the unit has the ability of working in full load, will decrease. Standard Ambient – Standard Noise models with reduction in fan speed convert to Low Noise models. These models keep 46 as maximum ambient temperature. Low sound type (LN) includes compressor enclosure (silencer box) and also operates with fans speed 150 rpm lower than standard noise type (SN). This makes them suitable for application including hospitals, schools and other sites located in residential neighborhoods. In part load operation, such as colder weather or night time duty, fans operate in lower speed. This results in even quieter operation.

In all “Low Noise” models “Maximum Ambient Temperature (MAT)” parameter shows maximum ambient temperature in which the units could be operating in low noise mode. Above this temperature the unit will work on “Standard Noise” mode.

Medium Ambient Temperature Version

This version of ACW units is available just in Low Noise types. Maximum ambient temperature which this units have the ability to run in full load and low noise mode is 43 °C, above that units will operate in Standard Noise mode.

Environmentally balanced

R-134a is a safe, non-toxic, efficient and environmentally Balanced refrigerant. Based on ASHRAE Standard 34-1992, R-134a is classified as an A1 (non-toxic and inflammable) refrigerant.

Standard Features

- All models use multiple BITZER easy-to-service Screw compressors.
- Controller manages the capacity of each compressor. Each compressor could operate in 4 step, 25%, 50%, 75% and 100%.
- On units with two or three compressors, Controller manages rotation in order to balance compressor operating hours and starts, so as to best deliver the required capacity.
- Easily accessible system components.
- Easy access to power and control panels.
- Heavy duty mounting chassis for the whole unit with lifting lugs.
- 3Phase control to protect the unit that install on input main power that operates in low or over voltage times.
- Internal crank case heaters prevent liquid refrigerant from accumulating in the compressors when the unit is shut down.
- High- and low-pressure switches, control discharge pressure and suction side pressure and cut-off compressors running when these pressures exceed the limits.
- Control panel that enables the operator to control and diagnoses malfunction of all controllers and compressors with thermo meter to indicate inlet and outlet chilled water temperature.

- Part winding starting for all 1-compressor models below size 330 and 2-compressors models below size 650. Star delta starting for units over size of 330 for 1-compressor models and 650 for 2-compressors models.
- One power supply entry
- After rigging the unit in its required location, installation of chiller is completed by simple connection of the power supply and water connection.
- Anti-vibration mounting for compressor
- Chilled water pump(s) and water flow switch interlock for electrical terminal field connection
- Capacity control stages through compressor unloading for superior part load performance.
- Heavy structure unit and weather proof paint polyester, powder paint for sheet metal and epoxy coating for base frame.
- IP54 power and control panel
- Anti-freeze protection that protects the evaporator from freezing and also protect compressors from slugging and flooding start.

Application Considerations

Accessing the unit

The access to the unit must be granted exclusively to qualified personnel trained to operate on this type of units and provided with the necessary protection equipment.

Important

Certain application constraints should be considered when sizing, selecting and installing ACW air-cooled chillers. Unit and system reliability are often dependent upon proper and complete compliance with these considerations.

Unit Sizing

Unit capacities are listed in the performance data section. Intentionally over sizing a unit to assure adequate capacity is not recommended. Erratic system operation and excessive compressor cycling are often a direct result of an oversized chiller. In addition, an oversized unit is usually more expensive to purchase, install, and operate. If over sizing is desired, consider using multiple units

Water Treatment

However, in designing ACW units the effect of fouling thermal resistance is considered but dirt, scale, products of corrosion and other foreign material will adversely affect heat transfer between the water and system components. Polluted chilled water in system gets more pressure drop than pure water and consequently, reduce water flow. Neither salt nor brackish water is recommended for use in ACW air-cooled chillers. Use of either will lead to a shortened life to an indeterminable degree.

Effect of Altitude

The performance data of chillers which tabled, are chillers operation in sea level. Increasing the altitude reduces the density of the air and thereby reduce the condenser capacity, which lead to decrease unit capacity and efficiency. In Appendix Table A-2 the effect of elevation mentioned as a multiplier.

Leaving Chilled Water Temperature

The chillers are rated as standard base on 7- 12°C Leaving - entering water temperature and 35°C ambient temperature. The performance data of the units are presented for customers based on 5 to 10°C range of leaving water temperatures and 30 to 52°C ambient temperatures. When the outlet water temperature decreases below 5°C, antifreeze will be activated and compressor(s) will be unloaded. Ethylene glycol is recommended to prevent freezing, if the customer needs are below the range of performance data table.

Water flow rate

Maximum and minimum water flow rates are determiner of minimum and maximum allowable temperature drop in evaporator, if the flow rate or temperature drop does not meet customer demand, a mixing loop is required like what is showed in the following picture.

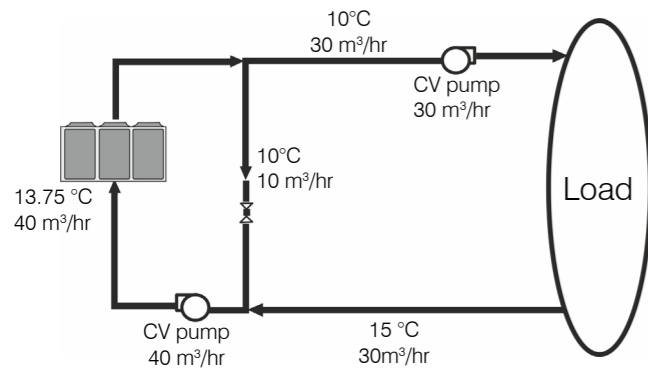

Figure 1 flow rate out of range

Leaving water temperature

If the Leaving Water Temperature (LWT) requirement is greater than 15 °C, a mixing loop is required like what is showed in the following picture.

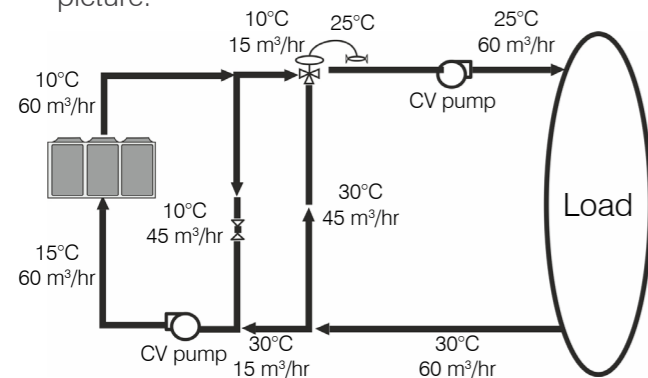

Figure 2 leaving water temperature out of range

Chilled Liquid Piping

All building water piping must be flushed prior to making the final connections to the chiller. To reduce heat loss and prevent condensation, insulation should be installed. Expansion tanks are also usually required so that chilled water volume changes can be accommodated.

The chilled liquid piping system must be laid out so that the circulating pump discharges directly into the cooler. The inlet and outlet chilled liquid connections are given in Technical Data. It is recommended to drain the circulation water circuit in out of operating season. If not able to drain, you should add the ethylene glycol with proper concentration to hydraulic circuit to protect against freeze up during low ambient periods.

Typical Unit Installation

It is recommended to install unit away from sound sensitive areas of the building or away windows. When physically isolating the unit from structures, it is a good idea to not use rigid supports, and to eliminate any metal-to-metal or hard material contact, when possible. This includes replacing spring or metal weave isolation with elastomeric isolators.

Pollution

The unit contains refrigerant gas and lubricating oil. During discarding such fluids must be recovered and eliminated according to the regulations in force in the country where the unit is installed. The unit must not be abandoned during discarding.

Foundation

Mount the unit on a level concrete foundation. Floors must be strong enough to support the unit operating weight. If necessary, use structural supports to transfer the weight of the unit to the nearest beams

Compressor

The very well-known European brand compressor designed for air conditioning by means of air-cooled liquid chillers in moderate condition. Using 4 step screw compressor capacity accompanied by controlling fan speed causes the series to become more compatible with different load condition during the application time (Partial Load Time).

REFRIGERANT CIRCUIT

Each compressor operates on an independent copper tubing refrigerant circuit. Refrigerant circuit components include the following, one each per circuit:

- Electronic expansion valve.
- Sight glass with moisture indicator.
- Shell and core filter-drier with high absorption removable core and charging port.
- Service valve on liquid line, gas discharge and suction line.
- Safety valve on high-pressure side.
- High pressure safety switch with manual reset.
- Low pressure safety switch with auto reset.
- Refrigerant circuit with copper tubing with anticondensate insulation of the suction line.
- Robust plastic capillary hoses for pressure sensors connection.

Condenser and fans

The condenser constructed with seamless inner-grooved copper tubes expanded into die-formed aluminum V-Waffle fins in staggered configuration. Coils are designed in "V" type to increase condensing surface area to maximized heat rejection.

The design working pressure is 450psig (31 bar).

"V" coils arrangement with internal baffle for fan cycling and staging.

Direct drive vertical discharge condenser fans are dynamically balanced. Three-phase condenser fan motors with permanently lubricated ball bearings and internal thermal overload protection are provided.

Evaporator

The evaporator is of the dry expansion shell and tube type with one, two or three independent refrigerant circuits and a single water circuit. The refrigerant flows inside the inner grooved copper tubes which increase exchange efficiency, while the water, which is oriented by baffles, flows over the outside of the tubes.

It is insulated with a 12-19 mm thick closed cell EPDM foam material.

Removable heads on the cooler allow access to internally-enhanced, seamless, copper tubes. Water vent and drain connections included.

ELECTRICAL PANEL

The electrical board is located in a metal case arranged outside the unit. The metal case has an IP54 protection rating and for force air ventilation a fan has located in the bottom of section and a filter in the top. In accordance with EN60204-1 norms, suitable for outdoor installation, complete with:

- Main switch.
- MCCB Circuit breaker for each Compressor and fan.
- Contactors for each load.
- Transformer for auxiliary circuit and Programable Controller supply.
- Power supply: 400/3/50.

Unit Controls

The microprocessor-based control panel is factory-installed and factory-tested. The control system is powered by a pre-wired control power supply, and will turn on, turn off and unload compressors in 4 steps to meet the load.

The panel includes machine protection for the following conditions:

- Low evaporator refrigerant temperature and pressure
- High condenser refrigerant pressure
- High compressor discharge temperature (with low temp evaporator)
- Electrical distribution faults: phase loss, phase reversal or over temperature protection
- External and local emergency stop
- Loss of evaporator water flow

Protective grilles

To protect condenser coil, evaporator and compressor from unauthorized access.

Flow switch

Paddle flow switch on the water circuit to avoid the risk of freezing if the water flow is shut off for some reason.

Compressor

All standard units' compressors are Bitzer M2 version except ACW31250HSSN, ACW31455HSSN, ACW31210SELN, ACW31395SELN. Hanbell compressors and Bitzer M1 versions are available for all models.

Condenser Coil – Anti Corrosion Coating

Our standard coils are constructed with Aluminum fins (This is not recommended for units in areas where they may be exposed to acid rain). In Harsh and Corrosive environments like oil Field and coast area application, copper fin with Heresite or Alcotherm Bly-Gold or Thermo Guard coating uses to protect air cooled heat exchangers.

Low Ambient Kit

The Standard Units will operate to minimum 10 °C. This accessory includes all necessary components to permit chiller operation down to -15 °C. Liquid receiver-heatexchanger and variable fan speed drive will necessarily install in unit.

Low Noise Fan

Incorporate low noise fans to reduce unit sound level.

BMS System

BACnet/Modbus translator control provides an interface between the chiller and a BACnet Local Area Network (LAN, i.e., MS/TP EIA-485). The BACnet/Modbus Translator control is also available as a factory-installed option. Field programming is required

Compressor Sound Insulator

This option includes acoustical treatment for compressors.

Vibration Isolators

Level adjusting, spring type 1" (25.4mm) or seismic deflection or neoprene pad isolators for mounting under unit base rails.

Standard Noise, Standard Ambient Temperature, 46°C, 1-Compressor Units

Refrigerant R-134a										
Unit ACW1.....SN		0100SS	0110SS	0130SS	0150SS	0185SS	0215SS	0245SS	0280SS	0310SS
Performance data										
Cooling Capacity	kW	100	112	132	152	184	214	245	280	312
Total Power Input	kW	32	36	44	50	63	69	81	91	104
EER	kW/kW	3.10	3.08	2.98	3.06	2.94	3.08	3.03	3.09	3.00
Energy Class	-	B	B	B	B	B	B	B	B	B
General Unit Data										
Independent Refrigerant Circuits Quantity	-	1	1	1	1	1	1	1	1	1
Refrigerant Charge	kg	40	46	54	63	78	89	104	117	133
Oil Charge	Liters	10	10	15	15	22	22	22	19	19
Compressors Qty per Chiller	-	1	1	1	1	1	1	1	1	1
Condensers, High Efficiency Fin/Tube with Integral Subcooler										
Number of Rows	-	3	3	4	3	3	3	3	4	3
Fins per inch	-	12								
Condenser Fans										
Type	-	Axial								
Number	-	2	2	2	3	3	4	4	4	5
Fan Motor	kW	1.94								
Fan & Motor Speed	RPM	900								
Fan Diameter	mm	800								
Evaporator, Direct Expansion										
Type		Shell & Tube								
Water Flow Rate	m3/hr	17.2	19.2	22.6	26.0	31.6	36.6	42.1	48.0	53.5
Cooler pressure drop	kpa	4	5	14	18	23	31	25	14	18
Maximum Water Side Pressure	Bar	10								
Maximum Refrigerant Side Pressure	Bar	19								
Maximum Chilled Water Flow Rate	m3/hr	20.2	22.5	26.6	30.7	37.0	42.8	49.2	56.0	62.5
Minimum Chilled Water Flow Rate	m3/hr	13.8	15.3	17.7	20.5	25.3	29.5	33.5	38.4	42.9
Nominal Water Connection Size	Inches	3	3	3	3	3	3	3	5	5
Electrical										
Power Supply	V/Ph/Hz	380~420/3/50								
Dimension & Weight										
Length	mm	3100	3100	3100	3100	3100	3100	3100	3100	4000
Width	mm	1300	1300	1300	2500	2500	2500	2500	2500	2500
Height	mm	2700	2700	2700	2700	2700	2700	2700	2700	2700
Weight	kg	1661	1718	1929	2220	2590	2723	2828	3117	3587

- Data referred to the following conditions:
 - Ambient air temperature 35 °C
 - Evaporator water inlet-outlet temperature 12-7 °C

Standard Noise, Standard Ambient Temperature, 46°C, 2-Compressor Units

Refrigerant R-134a											
Unit ACW2.....SN		0205SH	0230SH	0250SE	0295SE	0335SS	0375SH	0400SS	0425SS	0480SH	0500SS
Performance data											
Cooling Capacity	kW	204	228	252	296	336	377	398	427	480	498
Total Power Input	kW	65	73	91	103	112	121	132	139	147	163
EER	kW/kW	3.14	3.12	2.78	2.86	3.00	3.11	3.02	3.08	3.27	3.06
Energy Class	-	A	A	C	C	B	A	B	B	A	B
General Unit Data											
Independent Refrigerant Circuits Quantity	-	2	2	2	2	2	2	2	2	2	2
Refrigerant Charge	kg	82	92	104	121	138	154	164	174	195	205
Oil Charge	Liters	19	19	30	30	37	44	44	44	44	44
Compressors Qty per Chiller	-	2	2	2	2	2	2	2	2	2	2
Condensers, High Efficiency Fin/Tube with Integral Subcooler											
Number of Rows	-	3	3	3	4	3	4	3	3	4	3
Fins per inch	-	12									
Condenser Fans											
Type	-	Axial									
Number	-	4	4	4	4	6	6	7	8	8	8
Fan Motor	kW	1.94									
Fan & Motor Speed	RPM	900									
Fan Diameter	mm	800									
Evaporator, Direct Expansion											
Type		Shell & Tube									
Water Flow Rate	m3/hr	35.1	39.2	43.2	50.7	57.6	64.6	68.3	73.2	82.3	85.4
Cooler pressure drop	kpa	18	22	27	16	20	31	35	40	44	47
Maximum Water Side Pressure	Bar	10									
Maximum Refrigerant Side Pressure	Bar	19									
Maximum Chilled Water Flow Rate	m3/hr	41.0	45.8	50.9	59.7	67.5	75.4	79.7	85.4	96.0	99.7
Minimum Chilled Water Flow Rate	m3/hr	28.0	31.2	33.8	39.7	45.9	52.1	55.0	59.1	66.1	68.1
Nominal Water Connection Size	Inches	3	3	3	5	5	5	5	5	5	5
Electrical											
Power Supply	V/Ph/Hz	380~420/3/50									
Dimension & Weight											
Length	mm	3100	3100	3100	3100	4000	4000	5200	5200	5200	5200
Width	mm	2500	2500	2500	2500	2500	2500	2500	2500	2500	2500
Height	mm	2700	2700	2700	2700	2700	2700	2700	2700	2700	2700
Weight	kg	2594	2706	3008	3301	4199	4729	4980	5112	5555	5363

- Data referred to the following conditions:
 - Ambient air temperature 35 °C
 - Evaporator water inlet-outlet temperature 12-7 °C

Standard Noise, Standard Ambient Temperature, 46°C, 2-Compressor Units

Refrigerant R-134a										
Unit ACW2.....SN		0565SH	0620SS	0710SH	0760SH	0830SP	0870SH	1035SP	1085SH	
Performance data										
Cooling Capacity	kW	563	619	712	758	832	871	1035	1086	
Total Power Input	kW	180	208	216	235	250	271	308	331	
EER	kW/kW	3.13	2.98	3.29	3.23	3.33	3.21	3.36	3.28	
Energy Class	-	A	B	A	A	AA	A	AA	A	
General Unit Data										
Independent Refrigerant Circuits Quantity	-	2	2	2	2	2	2	2	2	
Refrigerant Charge	kg	233	258	290	309	344	368	430	452	
Oil Charge	Liters	38	38	49	60	60	60	60	60	
Compressors Qty per Chiller	-	2	2	2	2	2	2	2	2	
Condensers, High Efficiency Fin/Tube with Integral Subcooler										
Number of Rows	-	3	3	4	4	4	3	4	4	
Fins per inch	-	12								
Condenser Fans										
Type	-	Axial								
Number	-	10	10	12	12	13	14	16	16	
Fan Motor	kW	1.94								
Fan & Motor Speed	RPM	900								
Fan Diameter	mm	800								
Evaporator, Direct Expansion										
Type		Shell & Tube								
Water Flow Rate	m3/hr	96.5	106.1	122.0	129.9	142.7	149.3	177.5	186.2	
Cooler pressure drop	kpa	44	52	55	62	58	63	58	63	
Maximum Water Side Pressure	Bar	10								
Maximum Refrigerant Side Pressure	Bar	19								
Maximum Chilled Water Flow Rate	m3/hr	112.6	123.6	142.5	151.6	166.5	174.1	206.1	215.8	
Minimum Chilled Water Flow Rate	m3/hr	77.6	85.3	98.0	103.9	114.3	119.8	144.8	152.0	
Nominal Water Connection Size	Inches	5	5	6	6	6	6	8	8	
Electrical										
Power Supply	V/Ph/Hz	380~420/3/50								
Dimension & Weight										
Length	mm	6400	6400	7600	7600	8900	8900	10100	10100	
Width	mm	2500	2500	2500	2500	2500	2500	2500	2500	
Height	mm	2700	2700	2700	2700	2700	2700	2900	2900	
Weight	kg	6275	6320	7820	8249	9014	8827	10325	10377	

- Data referred to the following conditions:
 - Ambient air temperature 35 °C
 - Evaporator water inlet-outlet temperature 12-7 °C

Standard Noise, Standard Ambient Temperature, 46°C, 3-Compressor Units

Refrigerant R-134a										
Unit ACW3.....SN		1510SH	1540SP							
Performance data										
Cooling Capacity	kW	1511	1538							
Total Power Input	kW	472	461							
EER	kW/kW	3.20	3.34							
Energy Class	-	A	AA							
General Unit Data										
Independent Refrigerant Circuits Quantity	-	3	3							
Refrigerant Charge	kg	622	628							
Oil Charge	Liters	90	90							
Compressors Qty per Chiller	-	3	3							
Condensers, High Efficiency Fin/Tube with Integral Subcooler										
Number of Rows	-	4	4							
Fins per inch	-	12								
Condenser Fans										
Type	-	Axial								
Number	-	21	24							
Fan Motor	kW	1.94								
Fan & Motor Speed	RPM	900								
Fan Diameter	mm	800								
Evaporator, Direct Expansion										
Type		Shell & Tube								
Water Flow Rate	m ³ /hr	259.0	263.7							
Cooler pressure drop	kpa	68	70							
Maximum Water Side Pressure	Bar	10								
Maximum Refrigerant Side Pressure	Bar	19								
Maximum Chilled Water Flow Rate	m ³ /hr	298.4	303.5							
Minimum Chilled Water Flow Rate	m ³ /hr	211.3	215.8							
Nominal Water Connection Size	Inches	10	10							
Electrical										
Power Supply	V/Ph/Hz	380~420/3/50								
Dimension & Weight										
Length	mm	13700	14900							
Width	mm	2500	2500							
Height	mm	2900	2900							
Weight	kg	14267	14848							

- Data referred to the following conditions:
 - Ambient air temperature 35 °C
 - Evaporator water inlet-outlet temperature 12-7 °C

Standard Noise, High Ambient Temperature, 50°C, 1-Compressor Units

Refrigerant R-134a										
Unit ACW1.....SN		0100HH	0115HH	0135HH	0155HH	0190HH	0215HH	0255HH	0290HH	0325HP
Performance data										
Cooling Capacity	kW	102	114	137	155	191	217	253	290	326
Total Power Input	kW	32	35	43	48	60	67	79	88	98
EER	kW/kW	3.23	3.23	3.15	3.21	3.17	3.23	3.23	3.28	3.32
Energy Class	-	A	A	A	A	A	A	A	A	AA
General Unit Data										
Independent Refrigerant Circuits Quantity	-	1	1	1	1	1	1	1	1	1
Refrigerant Charge	kg	41	46	56	64	79	90	108	122	137
Oil Charge	Liters	10	10	15	15	22	22	22	19	19
Compressors Qty per Chiller	-	1	1	1	1	1	1	1	1	1
Condensers, High Efficiency Fin/Tube with Integral Subcooler										
Number of Rows	-	4	4	3	4	3	4	3	3	4
Fins per inch	-	12								
Condenser Fans										
Type	-	Axial								
Number	-	2	2	3	3	4	4	5	6	6
Fan Motor	kW	1.94								
Fan & Motor Speed	RPM	900								
Fan Diameter	mm	800								
Evaporator, Direct Expansion										
Type		Shell & Tube								
Water Flow Rate	m ³ /hr	17.5	19.6	23.4	26.5	32.8	37.3	43.4	49.7	55.9
Cooler pressure drop	kpa	4	5	15	19	25	32	27	15	19
Maximum Water Side Pressure	Bar	10								
Maximum Refrigerant Side Pressure	Bar	19								
Maximum Chilled Water Flow Rate	m ³ /hr	20.5	22.9	27.6	31.3	38.3	43.5	50.8	58.1	65.3
Minimum Chilled Water Flow Rate	m ³ /hr	13.2	14.7	17.2	19.6	24.9	28.4	32.6	37.5	42.4
Nominal Water Connection Size	Inches	3	3	3	3	3	3	3	5	5
Electrical										
Power Supply	V/Ph/Hz	380~420/3/50								
Dimension & Weight										
Length	mm	3100	3100	3100	3100	3100	3100	4000	4000	4000
Width	mm	1300	1300	2500	2500	2500	2500	2500	2500	2500
Height	mm	2700	2700	2700	2700	2700	2700	2700	2700	2700
Weight	kg	1715	1771	2208	2299	2713	2830	3382	3688	3872

- Data referred to the following conditions:
 - Ambient air temperature 35 °C
 - Evaporator water inlet-outlet temperature 12-7 °C

Standard Noise, High Ambient Temperature, 50°C, 2-Compressor Units

Refrigerant R-134a											
Unit ACW2.....SN		0210HH	0235HH	0255HH	0270HH	0300HH	0315HH	0350HH	0385HH	0410HH	0435HH
Performance data											
Cooling Capacity	kW	208	233	254	268	300	316	348	383	411	434
Total Power Input	kW	64	71	79	86	91	97	109	121	126	135
EER	kW/kW	3.27	3.28	3.21	3.11	3.29	3.25	3.19	3.17	3.26	3.23
Energy Class	-	A	A	A	A	A	A	A	A	A	A
General Unit Data											
Independent Refrigerant Circuits Quantity	-	2	2	2	2	2	2	2	2	2	2
Refrigerant Charge	kg	82	93	103	109	120	127	140	156	166	176
Oil Charge	Liters	19	19	25	30	30	30	37	44	44	44
Compressors Qty per Chiller	-	2	2	2	2	2	2	2	2	2	2
Condensers, High Efficiency Fin/Tube with Integral Subcooler											
Number of Rows	-	4	4	3	3	4	4	3	3	4	4
Fins per inch	-	12									
Condenser Fans											
Type	-	Axial									
Number	-	4	4	6	6	6	6	8	8	8	8
Fan Motor	kW	1.94									
Fan & Motor Speed	RPM	900									
Fan Diameter	mm	800									
Evaporator, Direct Expansion											
Type		Shell & Tube									
Water Flow Rate	m³/hr	35.7	40.0	43.5	45.9	51.3	54.2	59.6	65.6	70.5	74.4
Cooler pressure drop	kpa	19	23	27	30	16	18	21	32	37	41
Maximum Water Side Pressure	Bar	10									
Maximum Refrigerant Side Pressure	Bar	19									
Maximum Chilled Water Flow Rate	m³/hr	41.7	46.8	51.1	54.1	60.5	63.8	69.8	76.6	82.3	86.8
Minimum Chilled Water Flow Rate	m³/hr	26.8	29.9	32.3	33.8	37.8	39.9	44.8	49.9	53.9	56.9
Nominal Water Connection Size	Inches	3	3	3	3	5	5	5	5	5	5
Electrical											
Power Supply	V/Ph/Hz	380~420/3/50									
Dimension & Weight											
Length	mm	3100	3100	4000	4000	4000	4000	5200	5200	5200	5200
Width	mm	2500	2500	2500	2500	2500	2500	2500	2500	2500	2500
Height	mm	2700	2700	2700	2700	2700	2700	2700	2700	2700	2700
Weight	kg	2700	2813	3534	3685	4020	4032	4723	5094	5316	5326

- Data referred to the following conditions:
 - Ambient air temperature 35 °C
 - Evaporator water inlet-outlet temperature 12-7 °C

Standard Noise, High Ambient Temperature, 50°C, 2-Compressor Units

Refrigerant R-134a											
Unit ACW2.....SN		0485HP	0515HH	0575HH	0645HH	0720HP	0770HP	0845HP	0905HP	1050HP	1115HP
Performance data											
Cooling Capacity	kW	487	514	575	646	720	772	847	904	1049	1114
Total Power Input	kW	145	158	176	196	214	230	246	260	304	322
EER	kW/kW	3.36	3.26	3.27	3.30	3.36	3.36	3.45	3.48	3.46	3.46
Energy Class	-	AA	A	A	A	AA	AA	AA	AA	AA	AA
General Unit Data											
Independent Refrigerant Circuits Quantity	-	2	2	2	2	2	2	2	2	2	2
Refrigerant Charge	kg	198	212	236	264	294	316	350	376	440	465
Oil Charge	Liters	44	44	38	38	49	60	60	60	60	60
Compressors Qty per Chiller	-	2	2	2	2	2	2	2	2	2	2
Condensers, High Efficiency Fin/Tube with Integral Subcooler											
Number of Rows	-	4	3	3	4	4	4	4	4	4	4
Fins per inch	-	12									
Condenser Fans											
Type	-	Axial									
Number	-	9	10	12	12	13	14	15	16	18	20
Fan Motor	kW	1.94									
Fan & Motor Speed	RPM	900									
Fan Diameter	mm	800									
Evaporator, Direct Expansion											
Type		Shell & Tube									
Water Flow Rate	m³/hr	83.6	88.2	98.6	110.7	123.4	132.4	145.3	155.0	179.8	191.0
Cooler pressure drop	kpa	45	50	46	56	56	64	60	67	59	66
Maximum Water Side Pressure	Bar	10									
Maximum Refrigerant Side Pressure	Bar	19									
Maximum Chilled Water Flow Rate	m³/hr	97.4	102.9	115.1	128.9	144.1	154.5	169.5	180.4	208.8	221.4
Minimum Chilled Water Flow Rate	m³/hr	63.2	66.2	74.8	84.4	93.1	99.6	109.5	117.6	138.9	148.0
Nominal Water Connection Size	Inches	5	5	5	5	6	6	6	6	8	8
Electrical											
Power Supply	V/Ph/Hz	380~420/3/50									
Dimension & Weight											
Length	mm	6400	6400	7600	7600	8900	8900	10100	10100	11300	12500
Width	mm	2500	2500	2500	2500	2500	2500	2500	2500	2500	2500
Height	mm	2700	2700	2700	2700	2700	2700	2900	2900	2900	2900
Weight	kg	6255	6164	6828	7194	8274	8856	9595	9781	10960	11565

- Data referred to the following conditions:
 - Ambient air temperature 35 °C
 - Evaporator water inlet-outlet temperature 12-7 °C

Standard Noise, High Ambient Temperature, 50°C, 3-Compressor Units

Refrigerant R-134a										
Unit ACW3.....SN		1250HS	1455HS							
Performance data										
Cooling Capacity	kW	1251	1453							
Total Power Input	kW	422	474							
EER	kW/kW	2.96	3.06							
Energy Class	-	B	B							
General Unit Data										
Independent Refrigerant Circuits Quantity	-	3	3							
Refrigerant Charge	kg	519	598							
Oil Charge	Liters	90	90							
Compressors Qty per Chiller	-	3	3							
Condensers, High Efficiency Fin/Tube with Integral Subcooler										
Number of Rows	-	3	4							
Fins per inch	-	12								
Condenser Fans										
Type	-	Axial								
Number	-	18	18							
Fan Motor	kW	1.94								
Fan & Motor Speed	RPM	900								
Fan Diameter	mm	800								
Evaporator, Direct Expansion										
Type		Shell & Tube								
Water Flow Rate	m³/hr	214.5	249.1							
Cooler pressure drop	kpa	78	63							
Maximum Water Side Pressure	Bar	10								
Maximum Refrigerant Side Pressure	Bar	19								
Maximum Chilled Water Flow Rate	m³/hr	248.5	287.5							
Minimum Chilled Water Flow Rate	m³/hr	161.9	190.0							
Nominal Water Connection Size	Inches	8	10							
Electrical										
Power Supply	V/Ph/Hz	380-420/3/50								
Dimension & Weight										
Length	mm	11300	11300							
Width	mm	2500	2500							
Height	mm	2900	2900							
Weight	kg	12172	13378							

- Data referred to the following conditions:
 - Ambient air temperature 35 °C
 - Evaporator water inlet-outlet temperature 12-7 °C

Low Noise, Medium and Standard Ambient Temperature, 1-Compressor Units

Refrigerant R-134a										
Unit ACW1.....LN		0100SS	0110SS	0125SE	0150SS	0180ME	0210SS	0240MS	0270MS	0305ME
Performance data										
Cooling Capacity	kW	98	109	127	149	179	209	238	270	303
Total Power Input	kW	32	36	45	49	64	69	82	93	106
EER	kW/kW	3.07	3.01	2.83	3.02	2.82	3.02	2.91	2.91	2.87
Energy Class	-	B	B	C	B	C	B	B	B	C
General Unit Data										
Independent Refrigerant Circuits Quantity	-	1	1	1	1	1	1	1	1	1
Refrigerant Charge	kg	40	45	53	62	77	88	102	115	131
Oil Charge	Liters	10	10	15	15	22	22	22	19	19
Compressors Qty per Chiller	-	1	1	1	1	1	1	1	1	1
Condensers, High Efficiency Fin/Tube with Integral Subcooler										
Number of Rows	-	3	3	4	3	3	3	3	4	3
Fins per inch	-	12								
Condenser Fans										
Type	-	Axial								
Number	-	2	2	2	3	3	4	4	4	5
Fan Motor	kW	1.21								
Fan & Motor Speed	RPM	750								
Fan Diameter	mm	800								
Evaporator, Direct Expansion										
Type		Shell & Tube								
Water Flow Rate	m³/hr	16.9	18.7	21.8	25.5	30.8	35.9	40.8	46.4	52.0
Cooler pressure drop	kpa	4	4	13	17	22	29	24	13	17
Maximum Water Side Pressure	Bar	10								
Maximum Refrigerant Side Pressure	Bar	19								
Maximum Chilled Water Flow Rate	m³/hr	19.7	21.9	25.7	30.0	35.9	41.9	47.8	54.1	60.7
Minimum Chilled Water Flow Rate	m³/hr	13.5	14.9	17.0	20.0	25.7	28.8	34.1	38.8	43.5
Nominal Water Connection Size	Inches	3	3	3	3	3	3	3	5	5
Electrical										
Power Supply	V/Ph/Hz	380-420/3/50								
Dimension & Weight										
Length	mm	3100	3100	3100	3100	3100	3100	3100	3100	4000
Width	mm	1300	1300	1300	2500	2500	2500	2500	2500	2500
Height	mm	2700	2700	2700	2700	2700	2700	2700	2700	2700
Weight	kg	1661	1718	1929	2220	2590	2723	2828	3117	3587

- Data referred to the following conditions:
 - Ambient air temperature 35 °C
 - Evaporator water inlet-outlet temperature 12-7 °C

Low Noise, Medium and Standard Ambient Temperature, 2-Compressor Units

Refrigerant R-134a											
Unit ACW2.....LN		0200SH	0225SS	0245ME	0285ME	0330MS	0365SS	0390MS	0420SS	0470SH	0485MS
Performance data											
Cooling Capacity	kW	200	223	243	283	328	367	389	418	468	484
Total Power Input	kW	65	73	92	106	113	123	133	139	148	165
EER	kW/kW	3.10	3.04	2.65	2.66	2.91	2.98	2.93	3.02	3.16	2.93
Energy Class	-	A	B	D	D	B	B	B	B	A	B
General Unit Data											
Independent Refrigerant Circuits Quantity	-	2	2	2	2	2	2	2	2	2	2
Refrigerant Charge	kg	81	91	102	118	136	152	162	172	192	202
Oil Charge	Liters	19	19	30	30	37	44	44	44	44	44
Compressors Qty per Chiller	-	2	2	2	2	2	2	2	2	2	2
Condensers, High Efficiency Fin/Tube with Integral Subcooler											
Number of Rows	-	3	3	3	4	3	4	3	3	4	3
Fins per inch	-	12									
Condenser Fans											
Type	-	Axial									
Number	-	4	4	4	4	6	6	7	8	8	8
Fan Motor	kW	1.21									
Fan & Motor Speed	RPM	750									
Fan Diameter	mm	800									
Evaporator, Direct Expansion											
Type		Shell & Tube									
Water Flow Rate	m³/hr	34.3	38.2	41.7	48.5	56.2	62.9	66.7	71.7	80.3	82.9
Cooler pressure drop	kpa	17	21	25	15	19	30	33	38	42	44
Maximum Water Side Pressure	Bar	10									
Maximum Refrigerant Side Pressure	Bar	19									
Maximum Chilled Water Flow Rate	m³/hr	40.2	44.6	49.1	57.0	65.8	73.4	77.8	83.6	93.5	96.7
Minimum Chilled Water Flow Rate	m³/hr	27.4	30.3	34.3	39.9	46.8	50.5	56.0	57.7	64.2	69.1
Nominal Water Connection Size	Inches	3	3	3	5	5	5	5	5	5	5
Electrical											
Power Supply	V/Ph/Hz	380~420/3/50									
Dimension & Weight											
Length	mm	3100	3100	3100	3100	4250	4250	5170	5170	5170	5170
Width	mm	2500	2500	2500	2500	2500	2500	2500	2500	2500	2500
Height	mm	2700	2700	2700	2700	2800	2800	2800	2800	2800	2800
Weight	kg	2594	2706	3008	3301	4199	4729	4980	5112	5555	5363

- Data referred to the following conditions:
 - Ambient air temperature 35 °C
 - Evaporator water inlet-outlet temperature 12-7 °C

Low Noise, Medium and Standard Ambient Temperature, 2-Compressor Units

Refrigerant R-134a									
Unit ACW2.....LN		0550SS	0600ME	0695SH	0735SH	0810SH	0845MH	1010SH	1055MH
Performance data									
Cooling Capacity	kW	550	602	694	736	809	847	1009	1056
Total Power Input	kW	180	211	218	237	252	272	312	337
EER	kW/kW	3.05	2.86	3.19	3.10	3.21	3.11	3.24	3.14
Energy Class	-	B	C	A	A	A	A	A	A
General Unit Data									
Independent Refrigerant Circuits Quantity	-	2	2	2	2	2	2	2	2
Refrigerant Charge	kg	230	254	286	304	339	362	424	445
Oil Charge	Liters	38	38	49	60	60	60	60	60
Compressors Qty per Chiller	-	2	2	2	2	2	2	2	2
Condensers, High Efficiency Fin/Tube with Integral Subcooler									
Number of Rows	-	3	3	4	4	4	3	4	4
Fins per inch	-	12							
Condenser Fans									
Type	-	Axial							
Number	-	10	10	12	12	13	14	16	16
Fan Motor	kW	1.21							
Fan & Motor Speed	RPM	750							
Fan Diameter	mm	800							
Evaporator, Direct Expansion									
Type		Shell & Tube							
Water Flow Rate	m³/hr	94.3	103.2	119.0	126.2	138.7	145.3	173.0	181.1
Cooler pressure drop	kpa	42	50	53	59	55	60	55	60
Maximum Water Side Pressure	Bar	10							
Maximum Refrigerant Side Pressure	Bar	19							
Maximum Chilled Water Flow Rate	m³/hr	110.0	120.1	138.9	147.3	161.8	169.3	200.8	209.8
Minimum Chilled Water Flow Rate	m³/hr	75.5	86.5	95.2	100.5	110.7	121.7	140.7	153.6
Nominal Water Connection Size	Inches	5	5	6	6	6	6	8	8
Electrical									
Power Supply	V/Ph/Hz	380~420/3/50							
Dimension & Weight									
Length	mm	6350	6350	7700	7700	8900	8900	10100	10100
Width	mm	2500	2500	2500	2500	2500	2500	2500	2500
Height	mm	2800	2800	2850	2850	2800	2800	2900	2900
Weight	kg	6275	6320	7820	8249	9014	8827	10325	10377

- Data referred to the following conditions:
 - Ambient air temperature 35 °C
 - Evaporator water inlet-outlet temperature 12-7 °C

Low Noise, Medium and Standard Ambient Temperature, 3-Compressor Units

Refrigerant R-134a										
Unit ACW3.....LN		1465MS	1500SH							
Performance data										
Cooling Capacity	kW	1465	1501							
Total Power Input	kW	482	466							
EER	kW/kW	3.04	3.22							
Energy Class	-	B	A							
General Unit Data										
Independent Refrigerant Circuits Quantity	-	3	3							
Refrigerant Charge	kg	611	620							
Oil Charge	Liters	90	90							
Compressors Qty per Chiller	-	3	3							
Condensers, High Efficiency Fin/Tube with Integral Subcooler										
Number of Rows	-	4	4							
Fins per inch	-	12								
Condenser Fans										
Type	-	Axial								
Number	-	21	24							
Fan Motor	kW	1.21								
Fan & Motor Speed	RPM	750								
Fan Diameter	mm	800								
Evaporator, Direct Expansion										
Type		Shell & Tube								
Water Flow Rate	m ³ /hr	251.1	257.4							
Cooler pressure drop	kpa	64	67							
Maximum Water Side Pressure	Bar	10								
Maximum Refrigerant Side Pressure	Bar	19								
Maximum Chilled Water Flow Rate	m ³ /hr	289.5	296.6							
Minimum Chilled Water Flow Rate	m ³ /hr	212.8	209.8							
Nominal Water Connection Size	Inches	10	10							
Electrical										
Power Supply	V/Ph/Hz	380~420/3/50								
Dimension & Weight										
Length	mm	13700	14900							
Width	mm	2500	2500							
Height	mm	2900	2900							
Weight	kg	14267	14848							

- Data referred to the following conditions:
 - Ambient air temperature 35 °C
 - Evaporator water inlet-outlet temperature 12-7 °C

Low Noise, Standard and High Ambient Temperature, 1-Compressor Units

Refrigerant R-134a											
Unit ACW1.....LN		0100HH	0110SH	0135HH	0150HH	0190SH	0215SH	0250SH	0285SH	0320SH	
Performance data											
Cooling Capacity	kW	100	111	134	151	188	213	248	285	320	
Total Power Input	kW	31	35	43	48	60	67	78	87	98	
EER	kW/kW	3.20	3.15	3.15	3.16	3.16	3.16	3.19	3.27	3.25	
Energy Class	-	A	A	A	A	A	A	A	A	A	
General Unit Data											
Independent Refrigerant Circuits Quantity	-	1	1	1	1	1	1	1	1	1	
Refrigerant Charge	kg	40	46	56	63	79	89	107	121	135	
Oil Charge	Liters	10	10	15	15	22	22	22	19	19	
Compressors Qty per Chiller	-	1	1	1	1	1	1	1	1	1	
Condensers, High Efficiency Fin/Tube with Integral Subcooler											
Number of Rows	-	4	4	3	4	3	4	3	3	4	
Fins per inch	-										
Condenser Fans											
Type	-	Axial									
Number	-	2	2	3	3	4	4	5	6	6	
Fan Motor	kW	1.21									
Fan & Motor Speed	RPM	750									
Fan Diameter	mm	800									
Evaporator, Direct Expansion											
Type		Shell & Tube									
Water Flow Rate	m ³ /hr	17.2	19.1	23.0	26.0	32.3	36.5	42.5	48.8	54.8	
Cooler pressure drop	kpa	4	5	15	18	24	30	26	15	18	
Maximum Water Side Pressure	Bar	10									
Maximum Refrigerant Side Pressure	Bar	19									
Maximum Chilled Water Flow Rate	m ³ /hr	20.1	22.4	27.1	30.6	37.7	42.6	49.8	57.0	63.9	
Minimum Chilled Water Flow Rate	m ³ /hr	12.9	15.3	16.8	19.1	25.9	29.4	34.0	39.2	44.1	
Nominal Water Connection Size	Inches	3	3	3	3	3	3	3	5	5	
Electrical											
Power Supply	V/Ph/Hz	380~420/3/50									
Dimension & Weight											
Length	mm	3100	3100	3100	3100	3100	3100	4250	4250	4250	
Width	mm	1300	1300	2500	2500	2500	2500	2500	2500	2500	
Height	mm	2700	2700	2700	2700	2700	2700	2800	2800	2800	
Weight	kg	1715	1771	2208	2299	2713	2830	3382	3688	3872	

- Data referred to the following conditions:
 - Ambient air temperature 35 °C
 - Evaporator water inlet-outlet temperature 12-7 °C

Low Noise, Standard and High Ambient Temperature, 2-Compressor Units

Refrigerant R-134a											
Unit ACW2.....LN		0205HH	0225SH	0250HH	0260HH	0295SH	0310SH	0340SH	0375SH	0405SH	0425SH
Performance data											
Cooling Capacity	kW	204	227	250	263	293	309	342	376	404	426
Total Power Input	kW	63	71	77	85	90	97	107	119	125	135
EER	kW/kW	3.24	3.19	3.25	3.11	3.25	3.20	3.20	3.16	3.22	3.16
Energy Class	-	A	A	A	A	A	A	A	A	A	A
General Unit Data											
Independent Refrigerant Circuits Quantity	-	2	2	2	2	2	2	2	2	2	2
Refrigerant Charge	kg	82	92	102	108	119	126	139	154	165	174
Oil Charge	Liters	19	19	25	30	30	30	37	44	44	44
Compressors Qty per Chiller	-	2	2	2	2	2	2	2	2	2	2
Condensers, High Efficiency Fin/Tube with Integral Subcooler											
Number of Rows	-	4	4	3	3	4	4	3	3	4	4
Fins per inch	-	12									
Condenser Fans											
Type	-	Axial									
Number	-	4	4	6	6	6	6	8	8	8	8
Fan Motor	kW	1.21									
Fan & Motor Speed	RPM	750									
Fan Diameter	mm	800									
Evaporator, Direct Expansion											
Type		Shell & Tube									
Water Flow Rate	m ³ /hr	35.0	39.0	42.8	45.1	50.3	52.9	58.7	64.5	69.3	73.0
Cooler pressure drop	kpa	18	22	26	29	16	17	21	31	36	39
Maximum Water Side Pressure	Bar	10									
Maximum Refrigerant Side Pressure	Bar	19									
Maximum Chilled Water Flow Rate	m ³ /hr	40.9	45.6	50.3	53.1	59.3	62.4	68.7	75.4	80.8	85.1
Minimum Chilled Water Flow Rate	m ³ /hr	26.2	31.0	31.7	33.0	39.6	41.7	46.9	52.0	56.0	59.0
Nominal Water Connection Size	Inches	3	3	3	3	5	5	5	5	5	5
Electrical											
Power Supply	V/Ph/Hz	380~420/3/50									
Dimension & Weight											
Length	mm	3100	3100	4250	4250	4250	4250	5170	5170	5170	5170
Width	mm	2500	2500	2500	2500	2500	2500	2500	2500	2500	2500
Height	mm	2700	2700	2800	2800	2800	2800	2800	2800	2800	2800
Weight	kg	2700	2813	3534	3685	4020	4032	4723	5094	5316	5326

- Data referred to the following conditions:
 - Ambient air temperature 35 °C
 - Evaporator water inlet-outlet temperature 12-7 °C

Low Noise, Standard and High Ambient Temperature, 2-Compressor Units

Refrigerant R-134a											
Unit ACW2.....LN		0480SP	0505SH	0565SH	0635SH	0705SH	0755SH	0830SP	0885SP	1030SP	1095SP
Performance data											
Cooling Capacity	kW	478	504	565	633	704	756	829	885	1028	1094
Total Power Input	kW	145	157	174	196	214	230	245	258	304	321
EER	kW/kW	3.30	3.22	3.26	3.24	3.29	3.29	3.38	3.43	3.38	3.41
Energy Class	-	AA	A	A	A	A	A	AA	AA	AA	AA
General Unit Data											
Independent Refrigerant Circuits Quantity	-	2	2	2	2	2	2	2	2	2	2
Refrigerant Charge	kg	196	210	234	261	290	312	345	372	435	460
Oil Charge	Liters	44	44	38	38	49	60	60	60	60	60
Compressors Qty per Chiller	-	2	2	2	2	2	2	2	2	2	2
Condensers, High Efficiency Fin/Tube with Integral Subcooler											
Number of Rows	-	4	3	3	4	4	4	4	4	4	4
Fins per inch	-	12									
Condenser Fans											
Type	-	Axial									
Number	-	9	10	12	12	13	14	15	16	18	20
Fan Motor	kW	1.21									
Fan & Motor Speed	RPM	750									
Fan Diameter	mm	800									
Evaporator, Direct Expansion											
Type		Shell & Tube									
Water Flow Rate	m ³ /hr	81.9	86.4	96.9	108.5	120.7	129.5	142.1	151.7	176.2	187.5
Cooler pressure drop	kpa	43	48	44	54	54	61	57	65	57	64
Maximum Water Side Pressure	Bar	10									
Maximum Refrigerant Side Pressure	Bar	19									
Maximum Chilled Water Flow Rate	m ³ /hr	95.4	100.8	113.1	126.4	141.0	151.2	165.8	176.7	204.6	217.3
Minimum Chilled Water Flow Rate	m ³ /hr	65.6	69.0	78.0	87.6	96.8	103.6	113.8	122.1	143.6	153.2
Nominal Water Connection Size	Inches	5	5	5	5	6	6	6	6	8	8
Electrical											
Power Supply	V/Ph/Hz	380~420/3/50									
Dimension & Weight											
Length	mm	6350	6350	7700	7700	8800	8900	10100	10100	11300	12500
Width	mm	2500	2500	2500	2500	2500	2500	2500	2500	2500	2500
Height	mm	2800	2800	2850	2850	2800	2800	2900	2900	2900	2900
Weight	kg	6255	6164	6828	7194	8274	8856	9595	9781	10960	11565

- Data referred to the following conditions:
 - Ambient air temperature 35 °C
 - Evaporator water inlet-outlet temperature 12-7 °C

Dimensions and Clearances

Low Noise, Standard Ambient Temperature, 3-Compressor Units

Refrigerant R-134a				
Unit ACW3.....LN		1210SE	1395SE	
Performance data				
Cooling Capacity	kW	1209	1396	
Total Power Input	kW	429	490	
EER	kW/kW	2.82	2.85	
Energy Class	-	C	C	
General Unit Data				
Independent Refrigerant Circuits Quantity	-	3	3	
Refrigerant Charge	kg	509	584	
Oil Charge	Liters	90	90	
Compressors Qty per Chiller	-	3	3	
Condensers, High Efficiency Fin/Tube with Integral Subcooler				
Number of Rows	-	3	4	
Fins per inch	-	12		
Condenser Fans				
Type	-	Axial		
Number	-	18	18	
Fan Motor	kW	1.21		
Fan & Motor Speed	RPM	750		
Fan Diameter	mm	800		
Evaporator, Direct Expansion				
Type		Shell & Tube		
Water Flow Rate	m ³ /hr	207.3	239.3	
Cooler pressure drop	kpa	73	58	
Maximum Water Side Pressure	Bar	10		
Maximum Refrigerant Side Pressure	Bar	19		
Maximum Chilled Water Flow Rate	m ³ /hr	240.3	276.3	
Minimum Chilled Water Flow Rate	m ³ /hr	166.1	193.0	
Nominal Water Connection Size	Inches	8	10	
Electrical				
Power Supply	V/Ph/Hz	380~420/3/50		
Dimension & Weight				
Length	mm	11300	11300	
Width	mm	2500	2500	
Height	mm	2900	2900	
Weight	kg	12172	13378	

- Data referred to the following conditions:
 - Ambient air temperature 35 °C
 - Evaporator water inlet–outlet temperature 12–7 °C

Note: Dimension may change! take last update of all model's dimension by contact Arvand experts.

Models				
ACW10100SSSN	ACW10100HHSN	ACW10110SSSN	ACW10115HHSN	ACW10130SSSN
ACW10100SSLN	ACW10100HHLN	ACW10110SSLN	ACW10110SHLN	ACW10125SELN

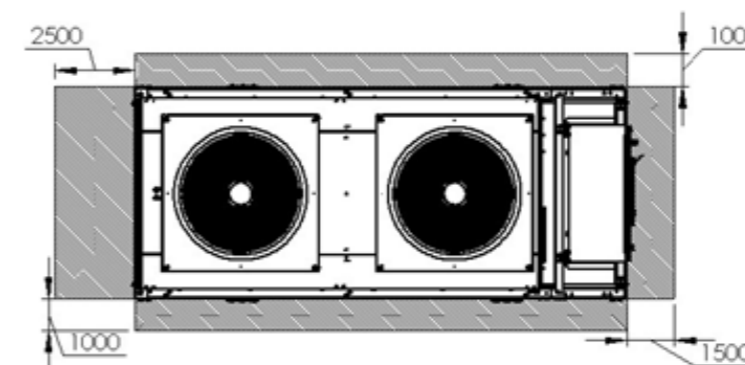
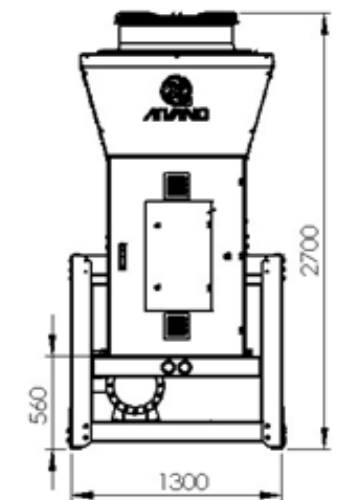
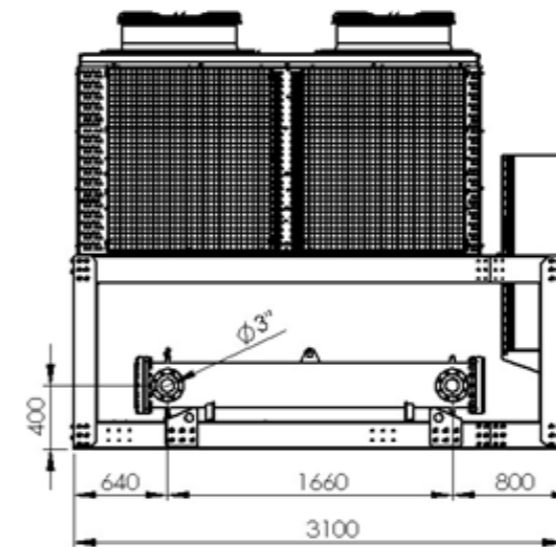

Models		
ACW10135HHSN	ACW10150SSSN	ACW10155HHSN
ACW10135HHLN	ACW10150SSLN	ACW10150HHLN

Models	
ACW10185SSSN	ACW10180MELN

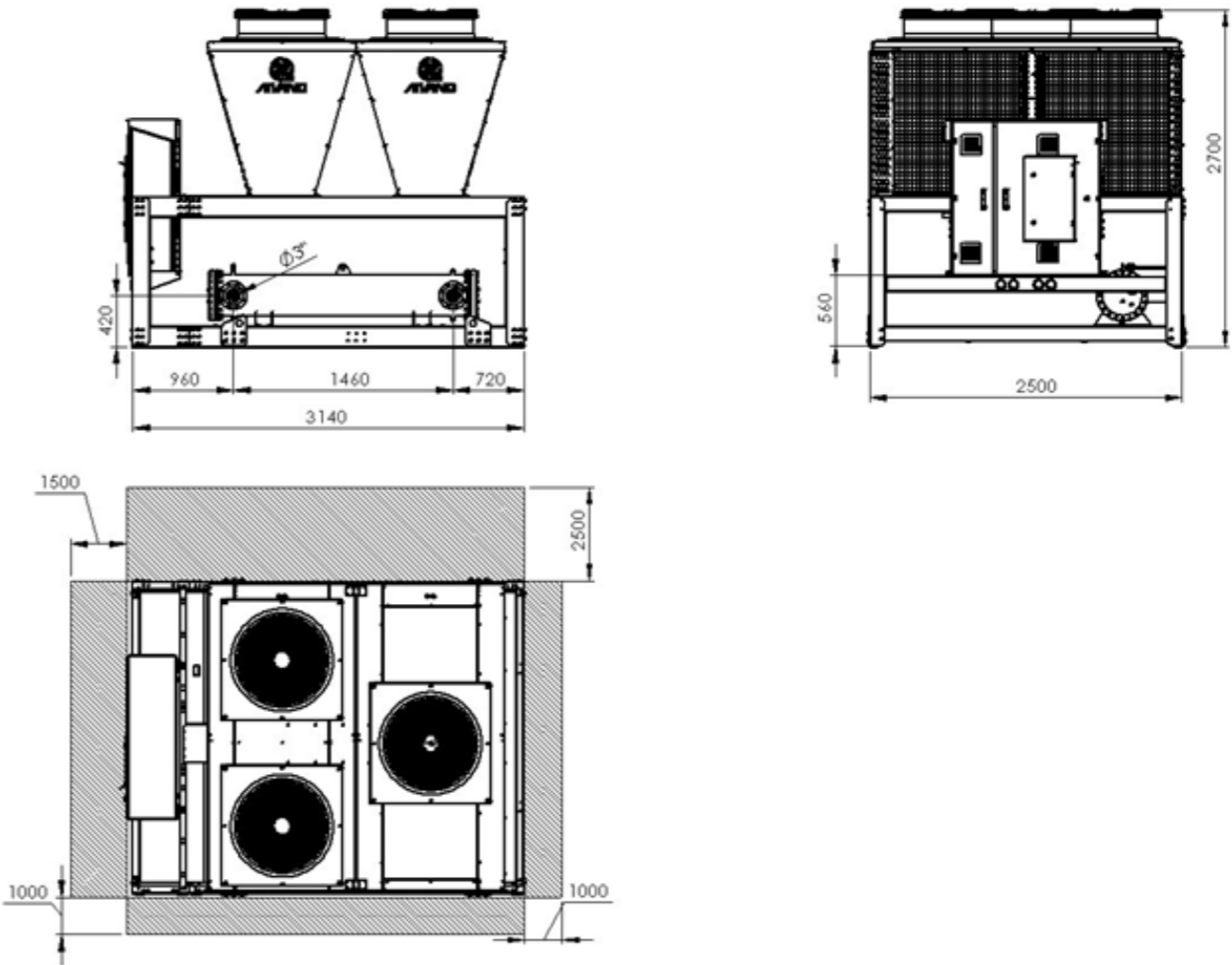
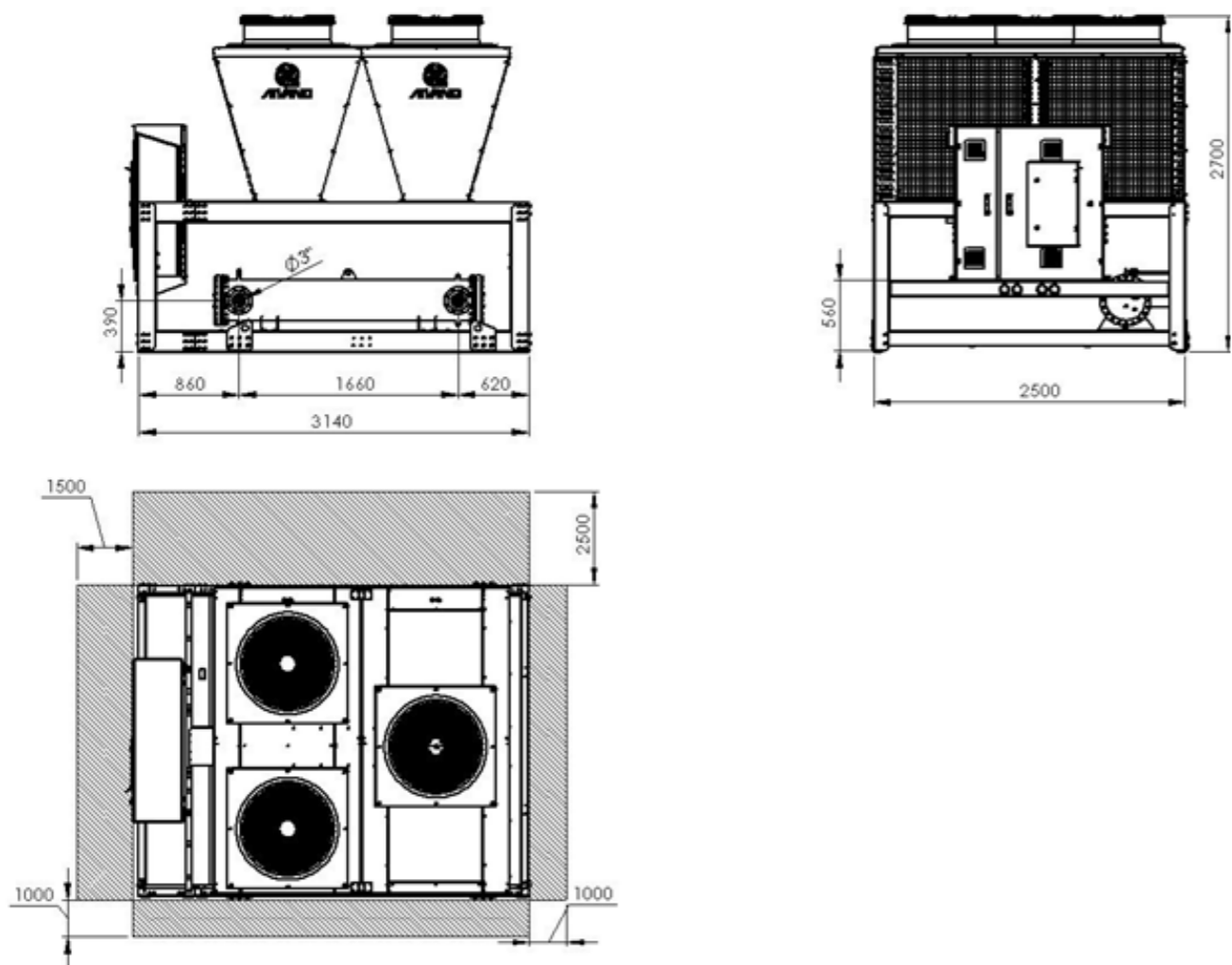

Models		
ACW10190HHSN	ACW10215SSSN	ACW10215HHSN
ACW10190SHLN	ACW10210SSLN	ACW10215SHLN

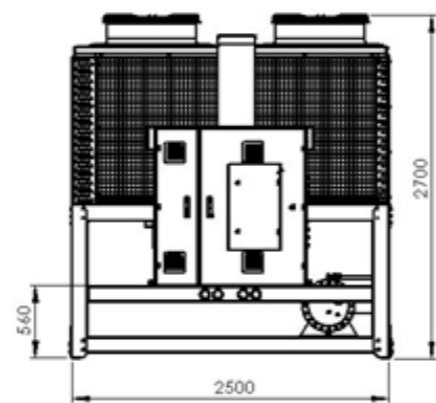
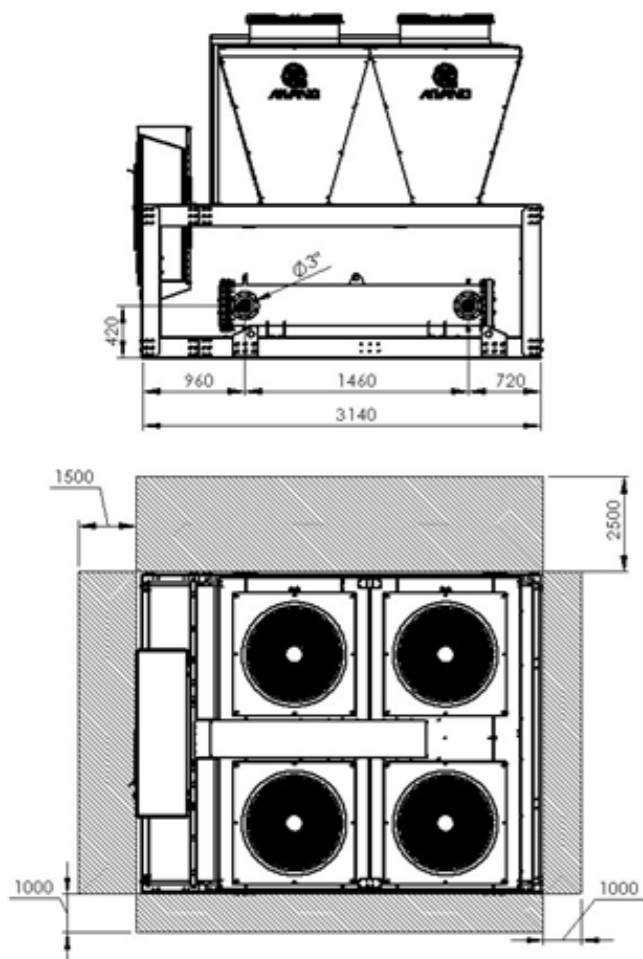

Models					
ACW10245SSSN	ACW20205SHSN	ACW20210HHSN	ACW20230SHSN	ACW20235HHSN	ACW20250SESN
ACW10240MSLN	ACW20200SHLN	ACW20205HHLN	ACW20225SSLN	ACW20225SHLN	ACW20245MELN

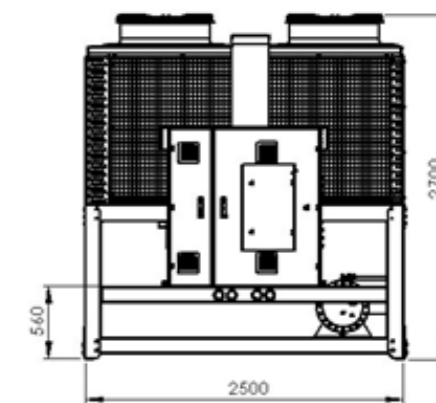
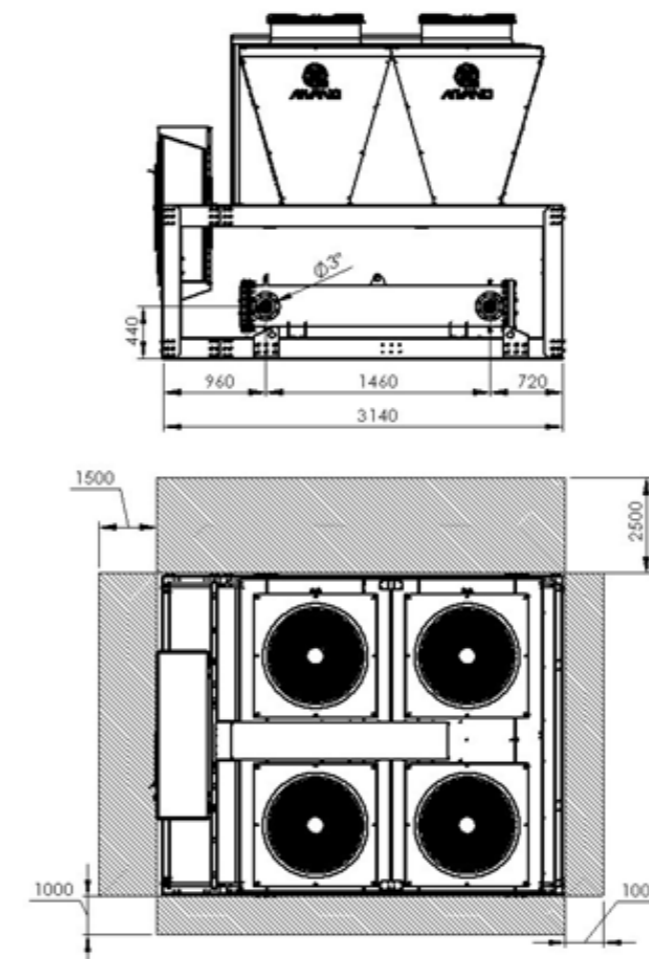

Models			
ACW10280SSSN	ACW20295SESN	ACW10270MSLN	ACW20285MELN

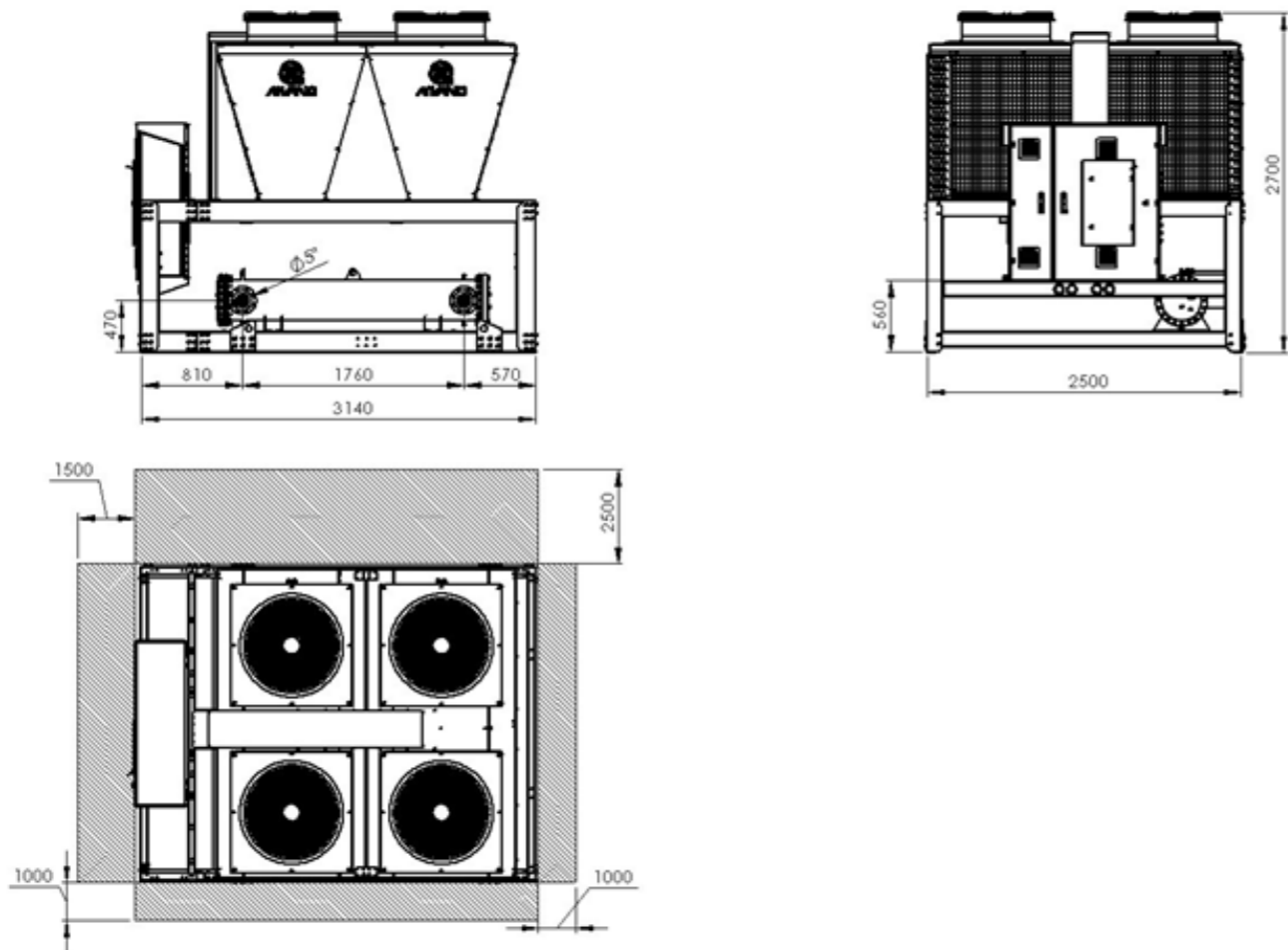

Models	
ACW10255HHSN	ACW10250SHLN

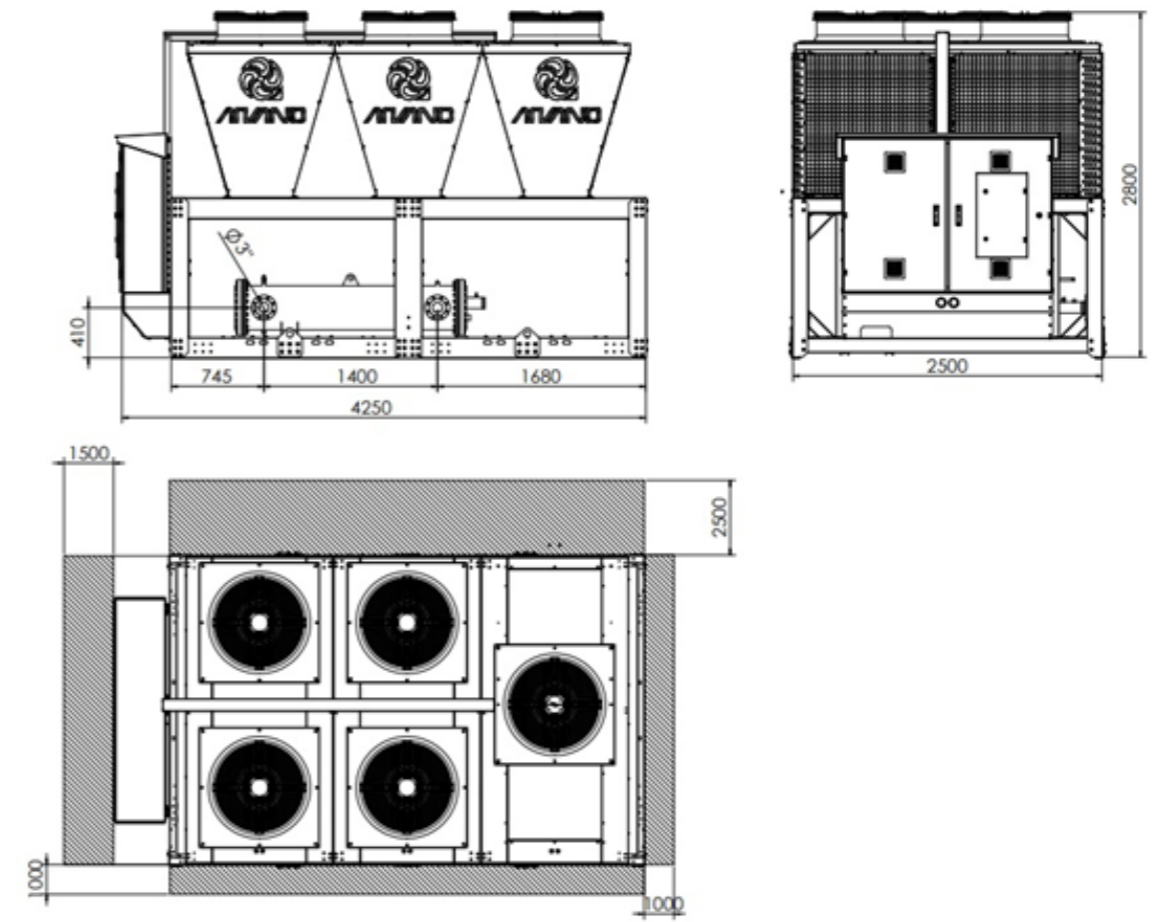

Models	
ACW10310SSSN	ACW10305MELN

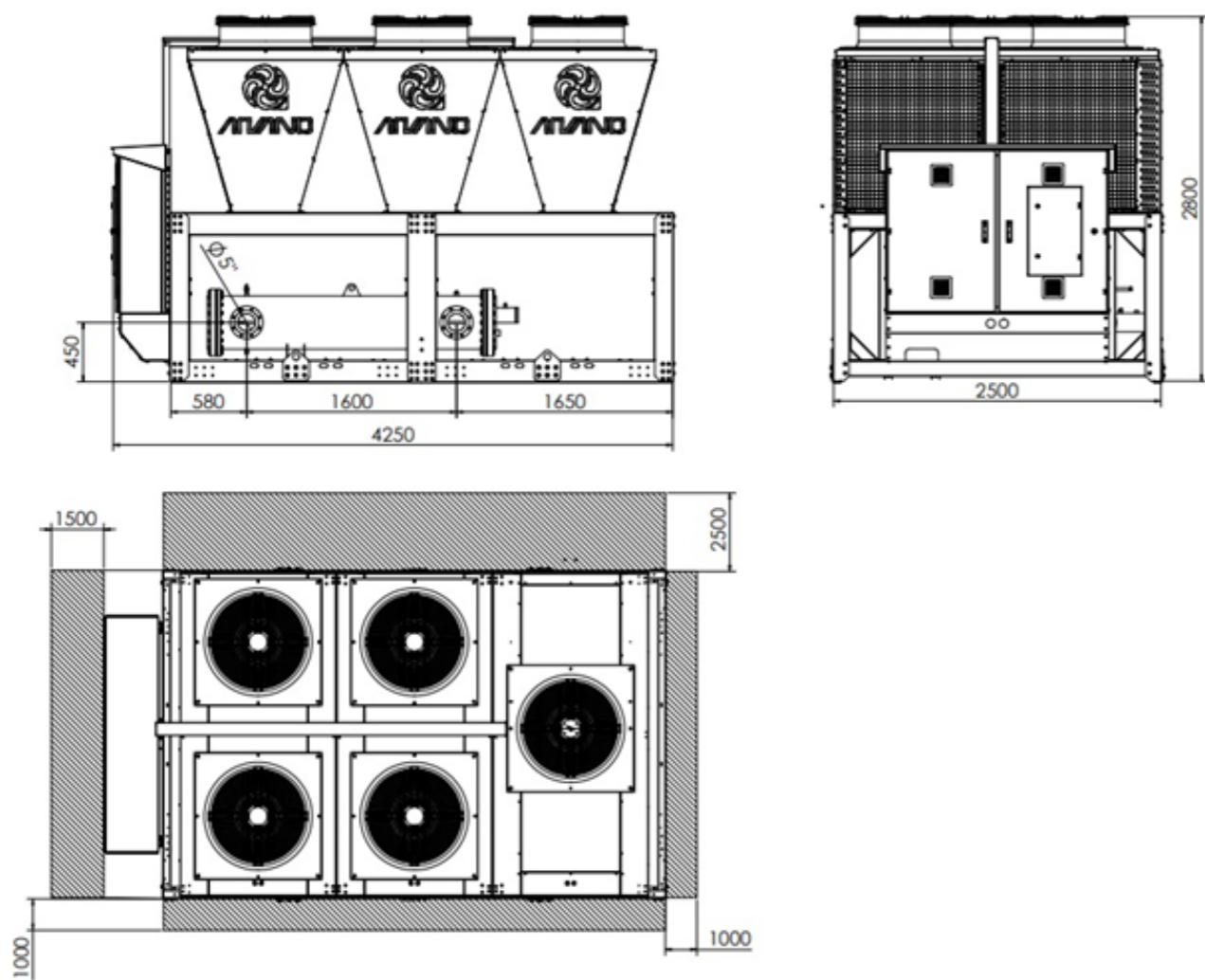

Models	
ACW20270HHSN	ACW20260HHLN

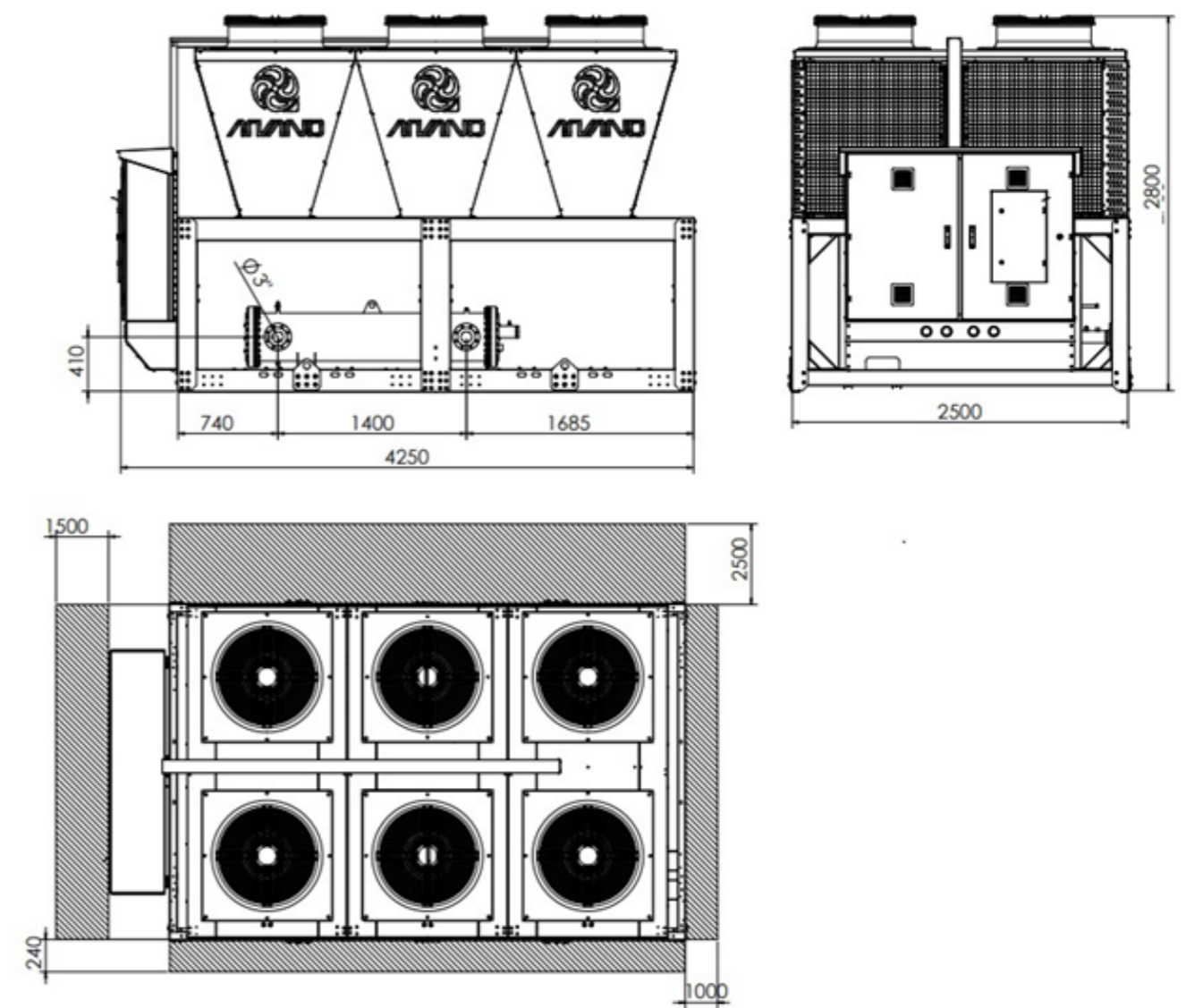

Models	
ACW20255HHSN	ACW20250HHLN

Models	
ACW20315HHSN	ACW20310SHLN

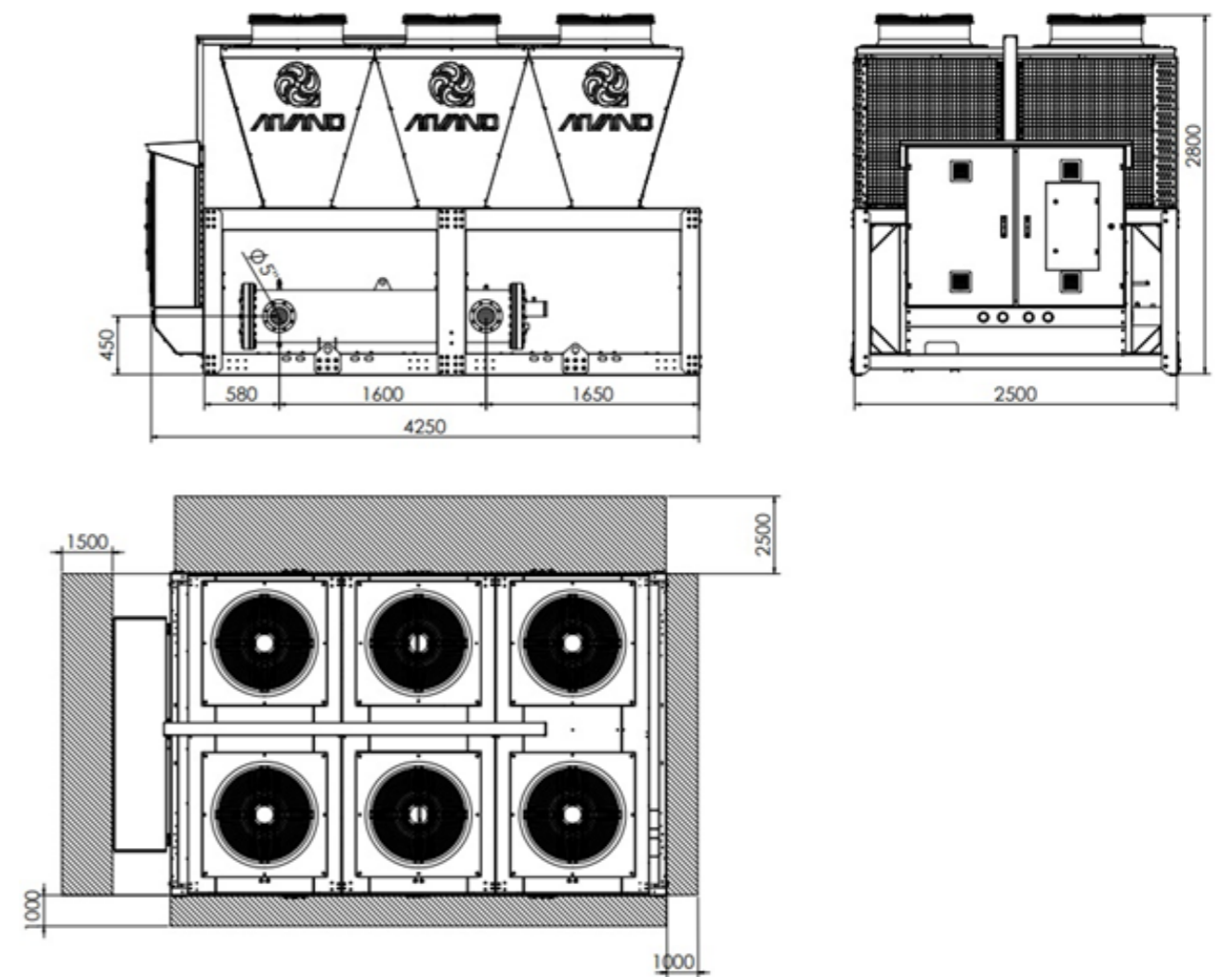
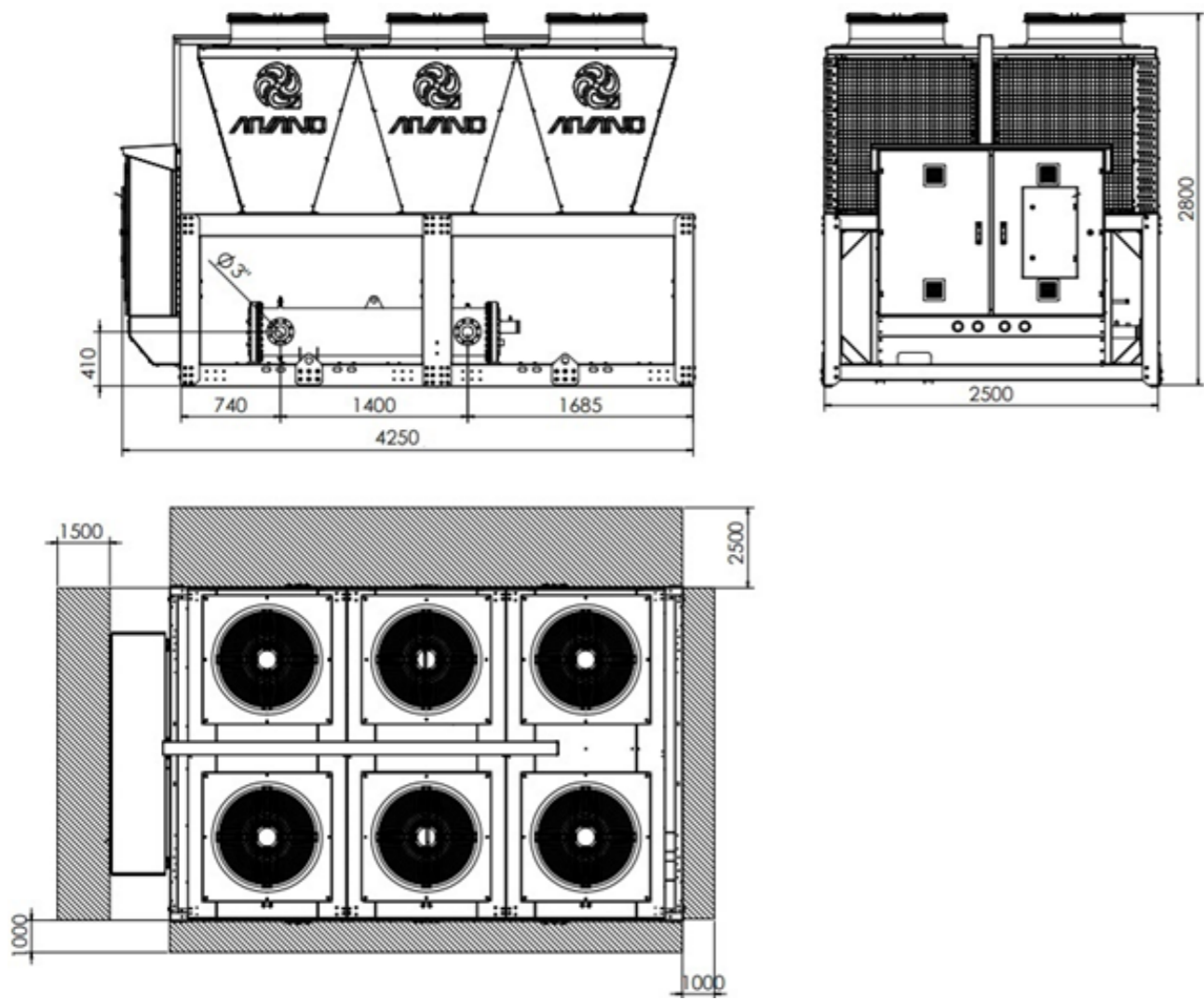

Models			
ACW20300HHSN	ACW20335SSSN	ACW20295SHLN	ACW20330MSLN

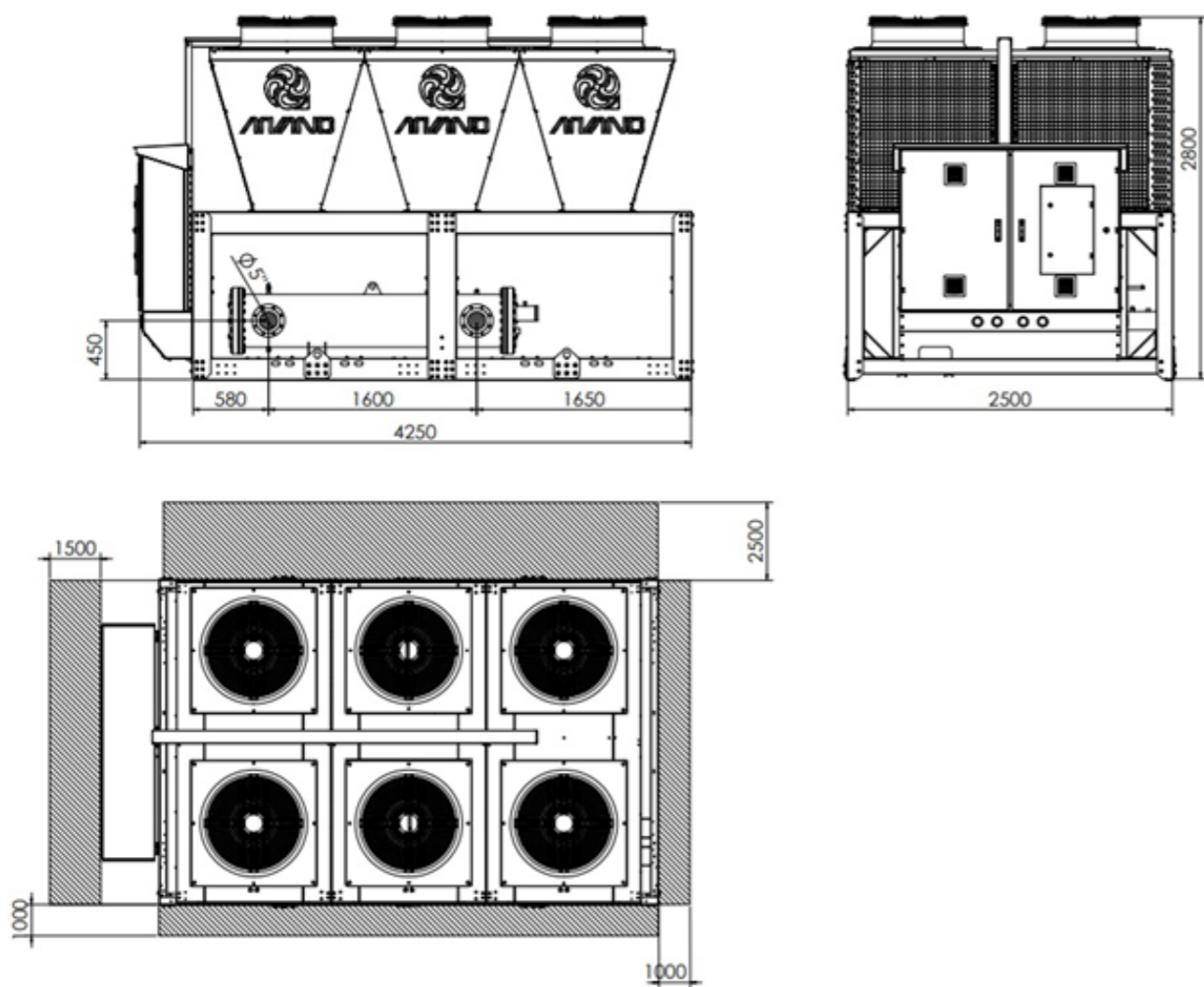

Models			
ACW10290HHSN	ACW10325HPSN	ACW10285SHLN	ACW10320SHLN

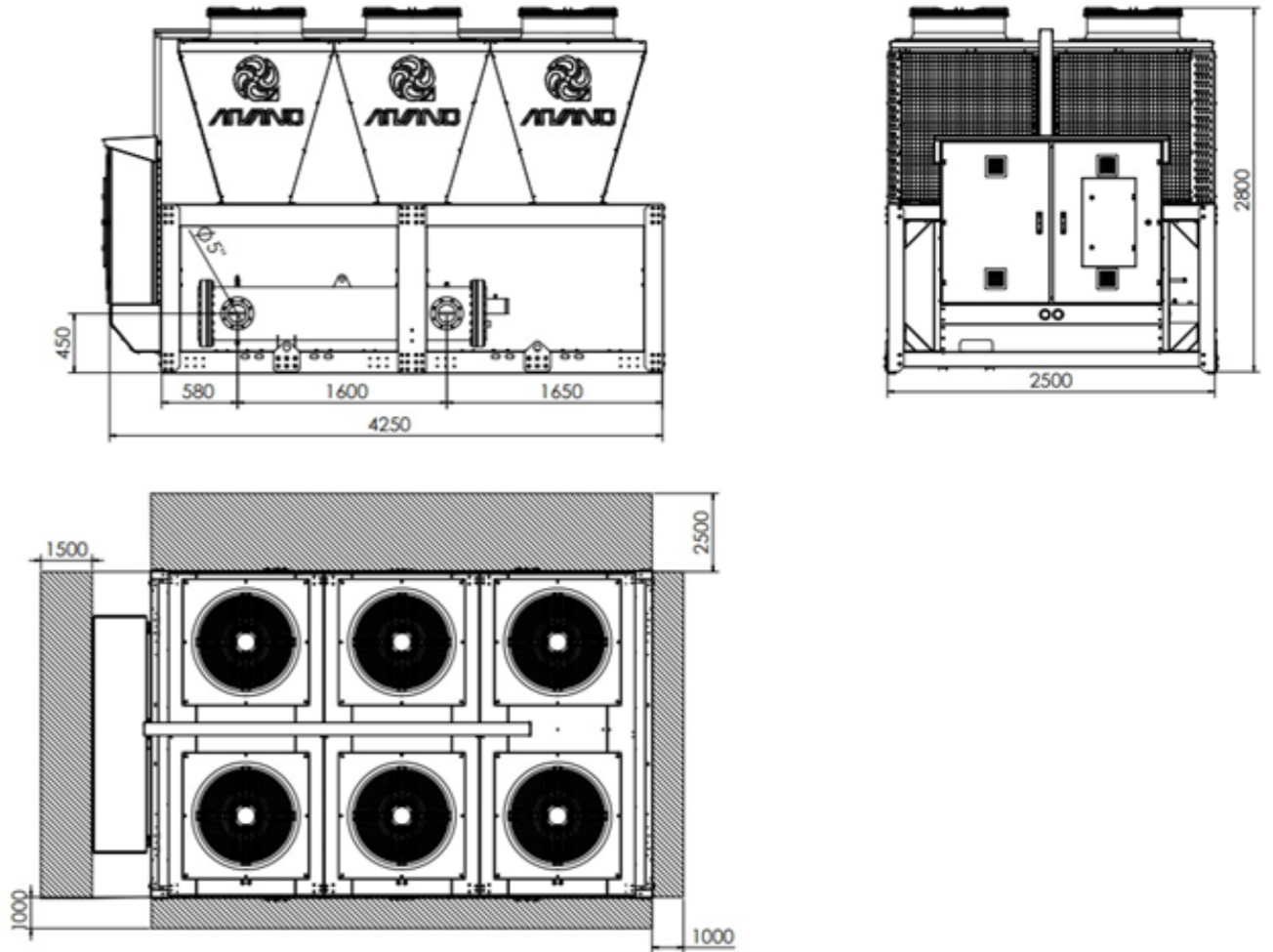

Models	
ACW20375SHSN	ACW20365SSLN

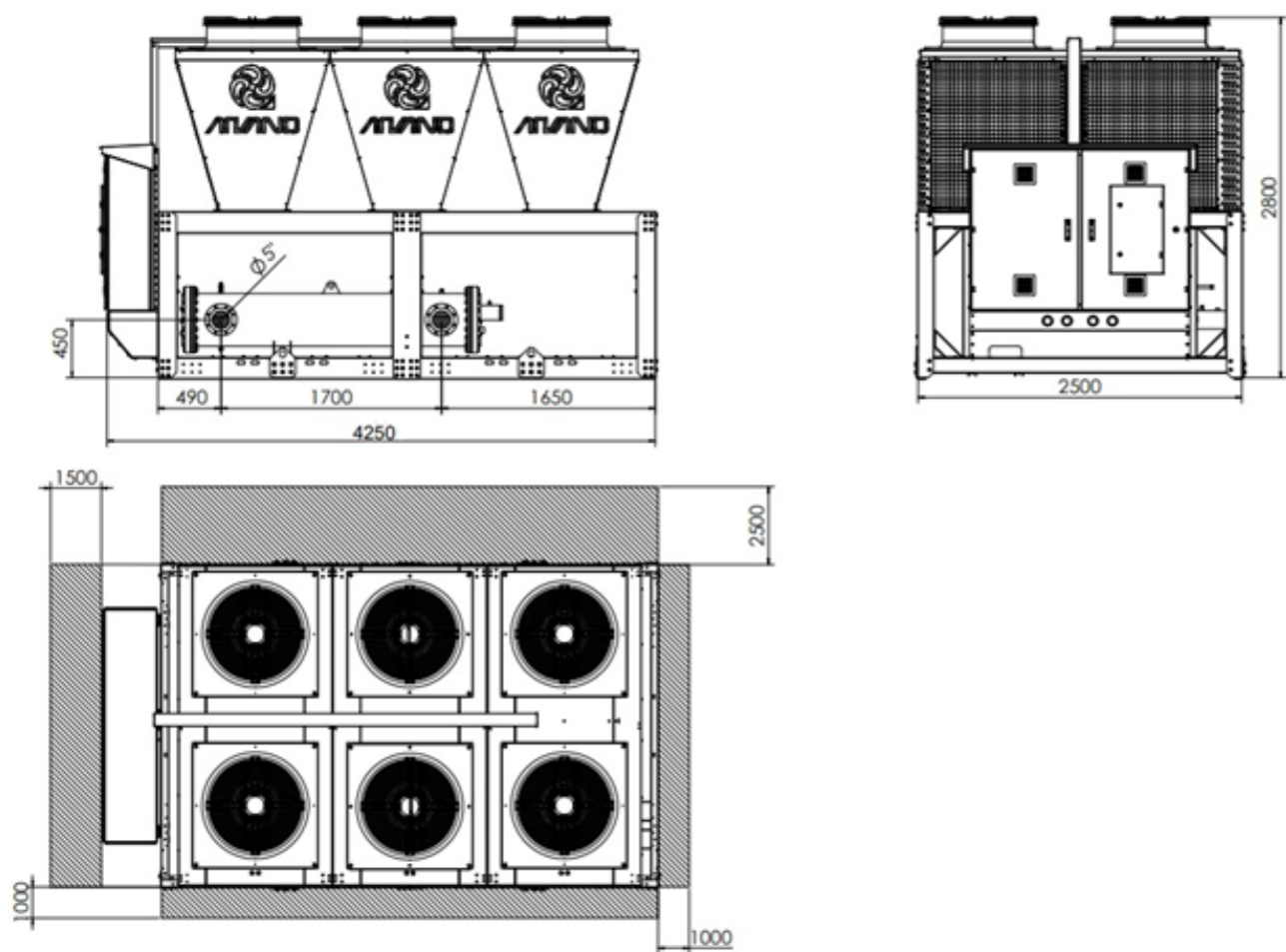

Models	
ACW20400SSSN	ACW20390MSLN

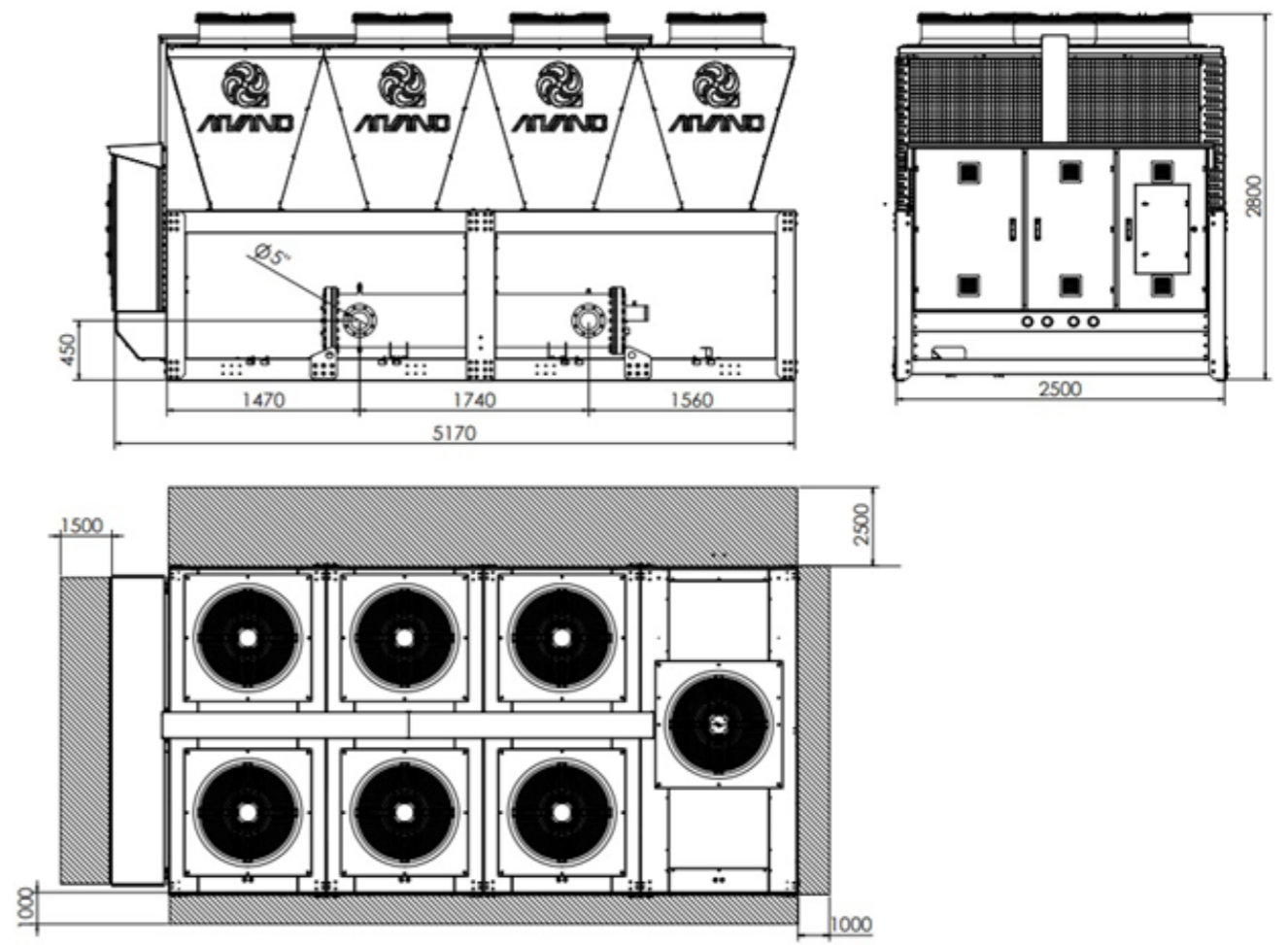

Models	
ACW20350HHSN	ACW20340SHLN

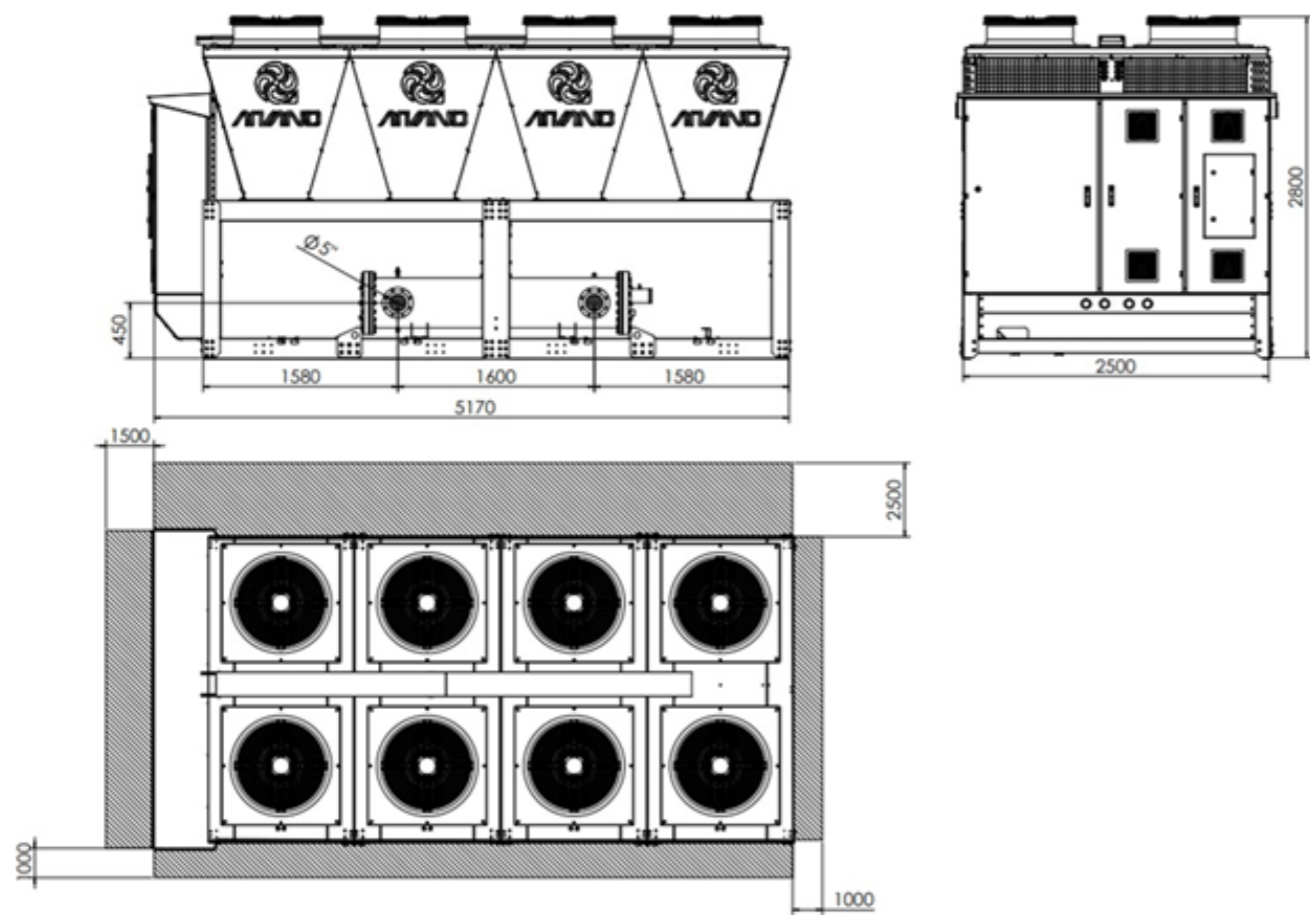

Models		
ACW20385HHSN	ACW20425SSSN	ACW20435HHSN
ACW20375SHLN	ACW20420SSLN	ACW20425SHLN

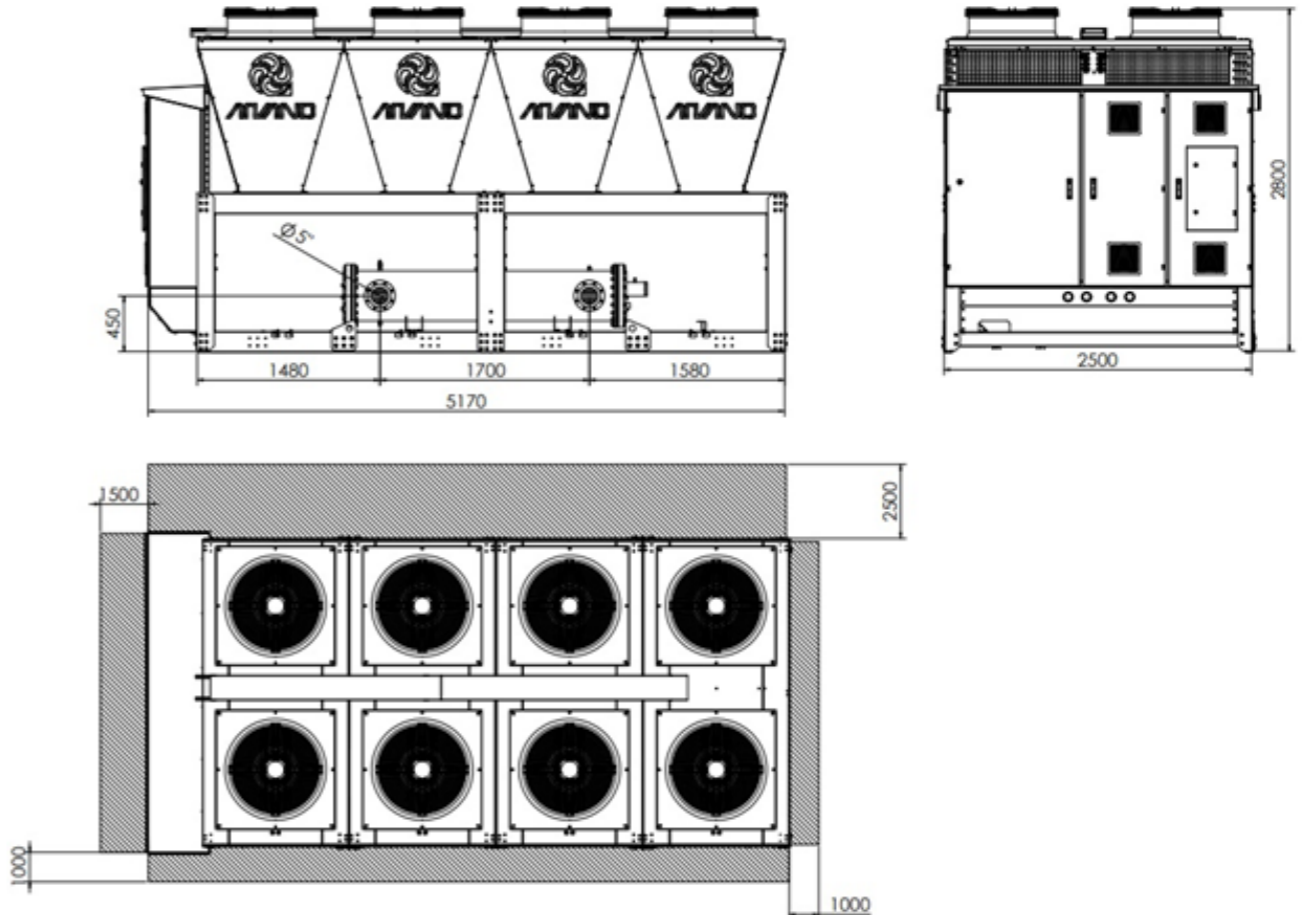

Models	
ACW20410HHSN	ACW20405SHLN

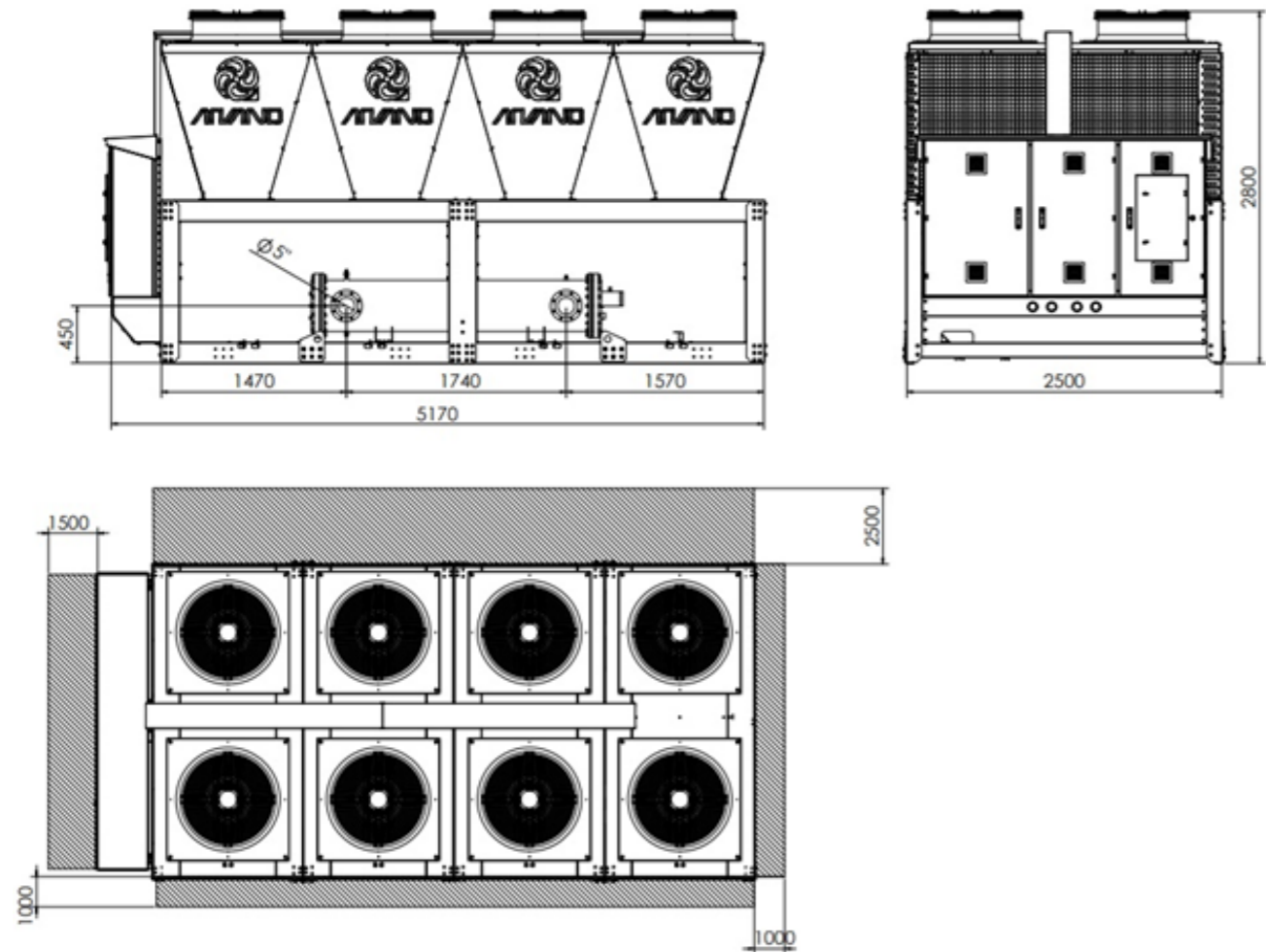

Models	
ACW20500SSSN	ACW20485MSLN

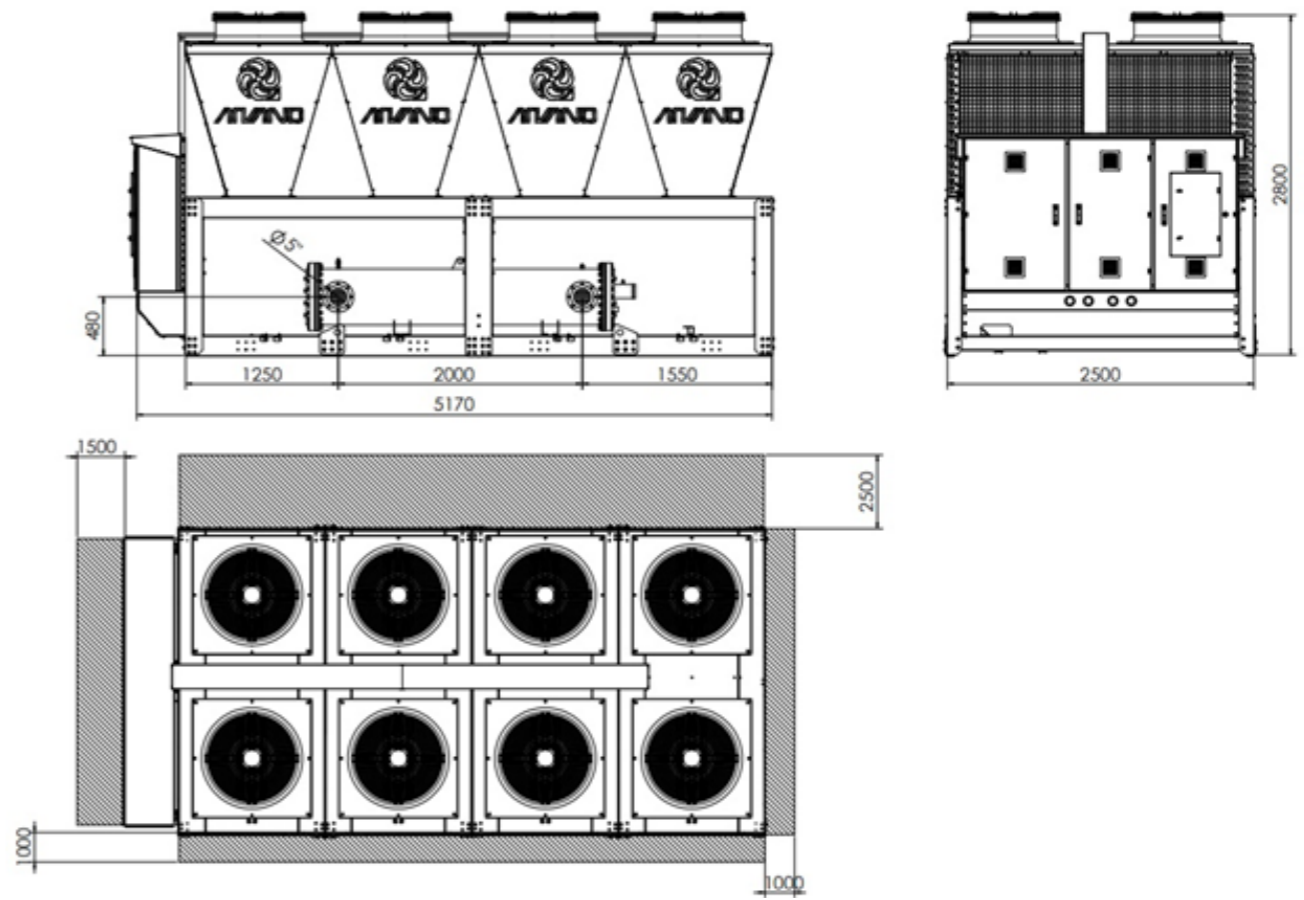

Models	
ACW20480SHSN	ACW20470SHLN

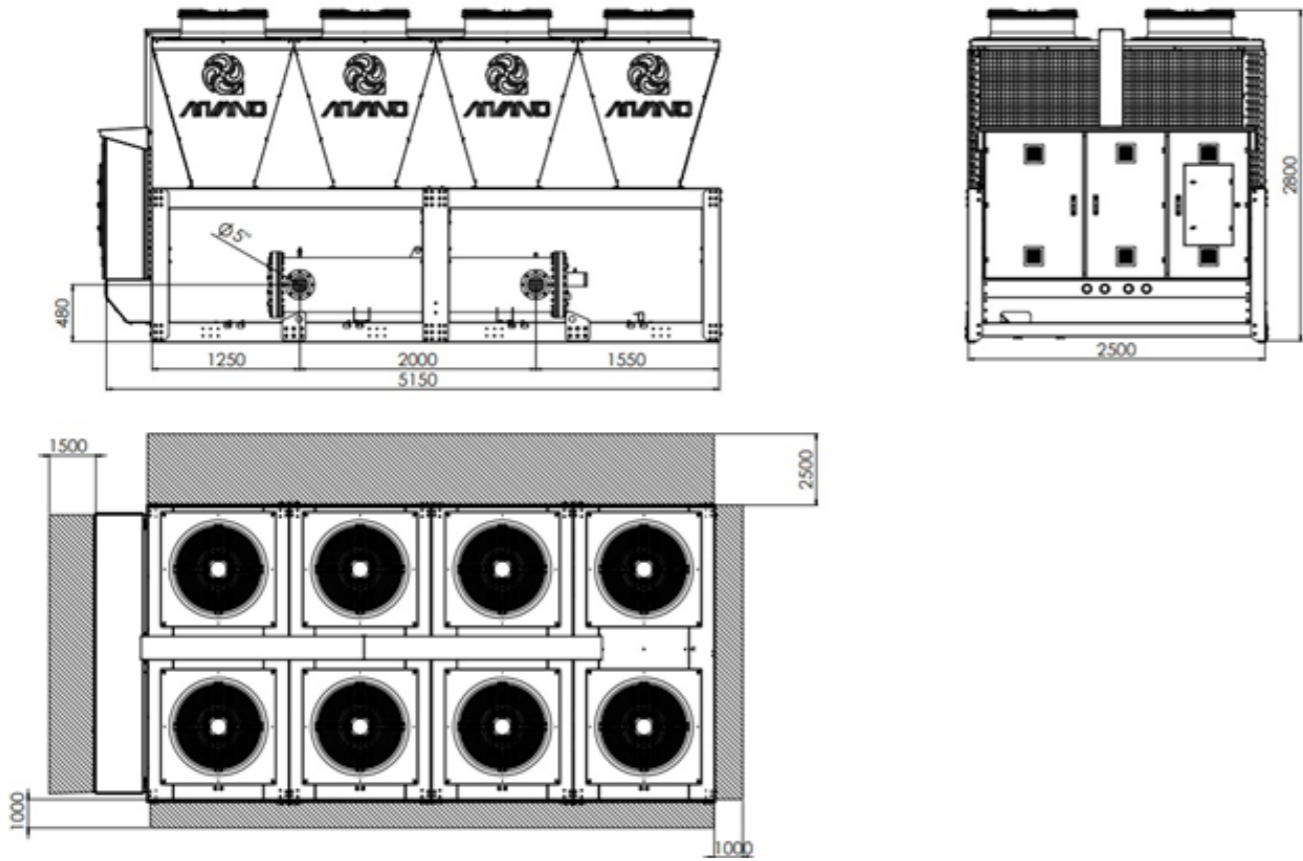

Models	
ACW20485HPSN	ACW20480SPLN

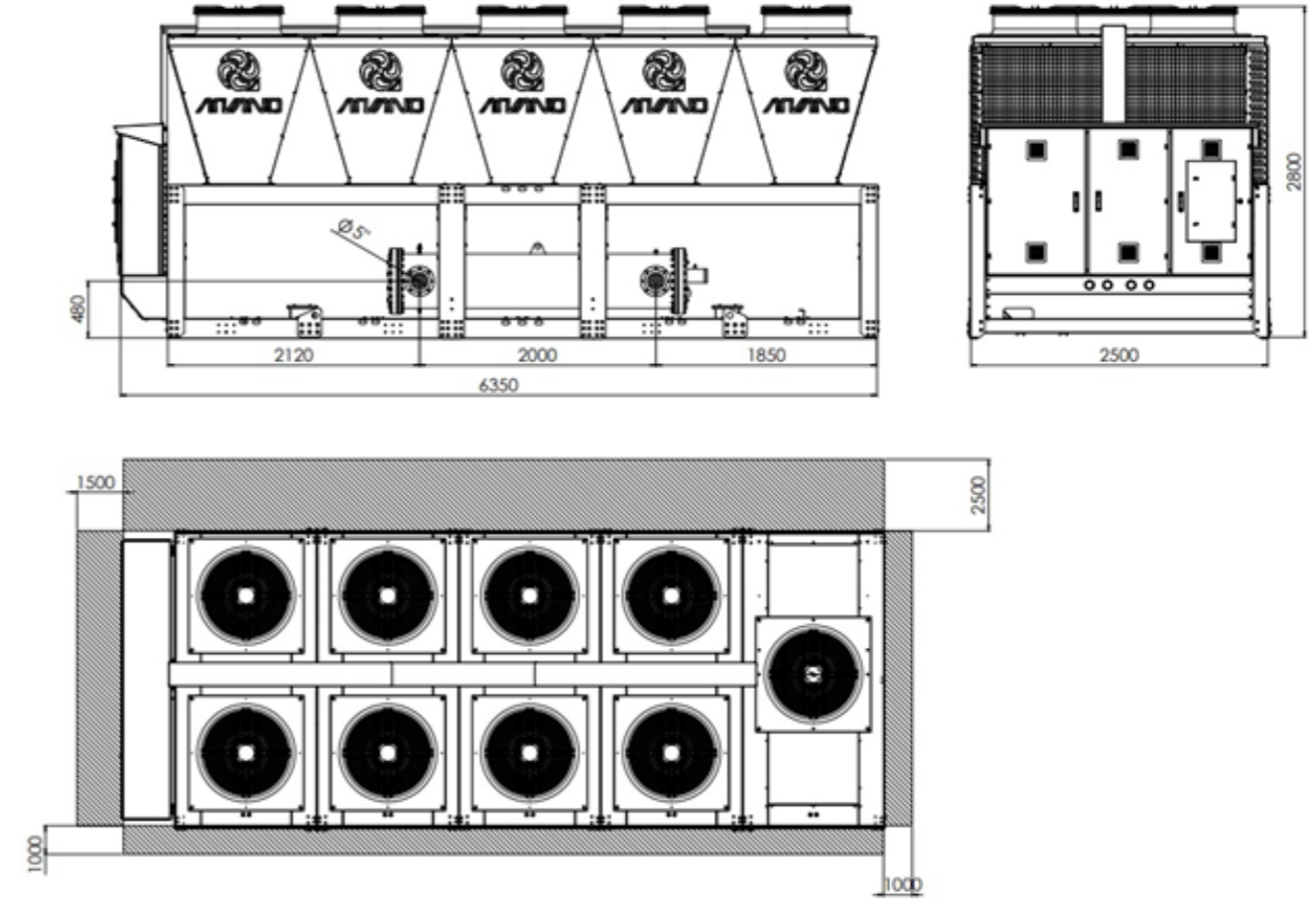

Models	
ACW20515HHSN	ACW20505SHLN

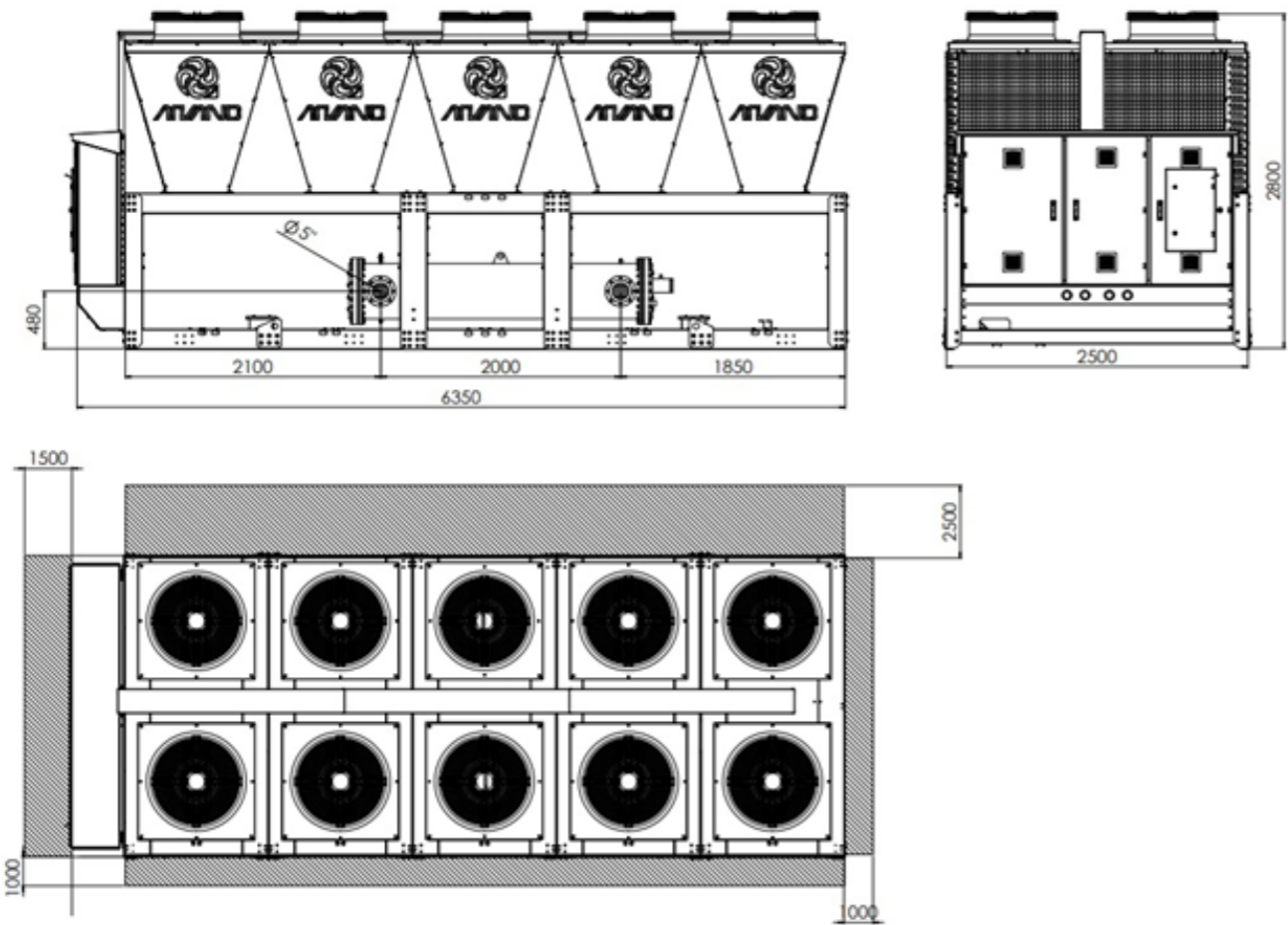

Models			
ACW20565SHSN	ACW20620SSSN	ACW20550SSLN	ACW20600MELN

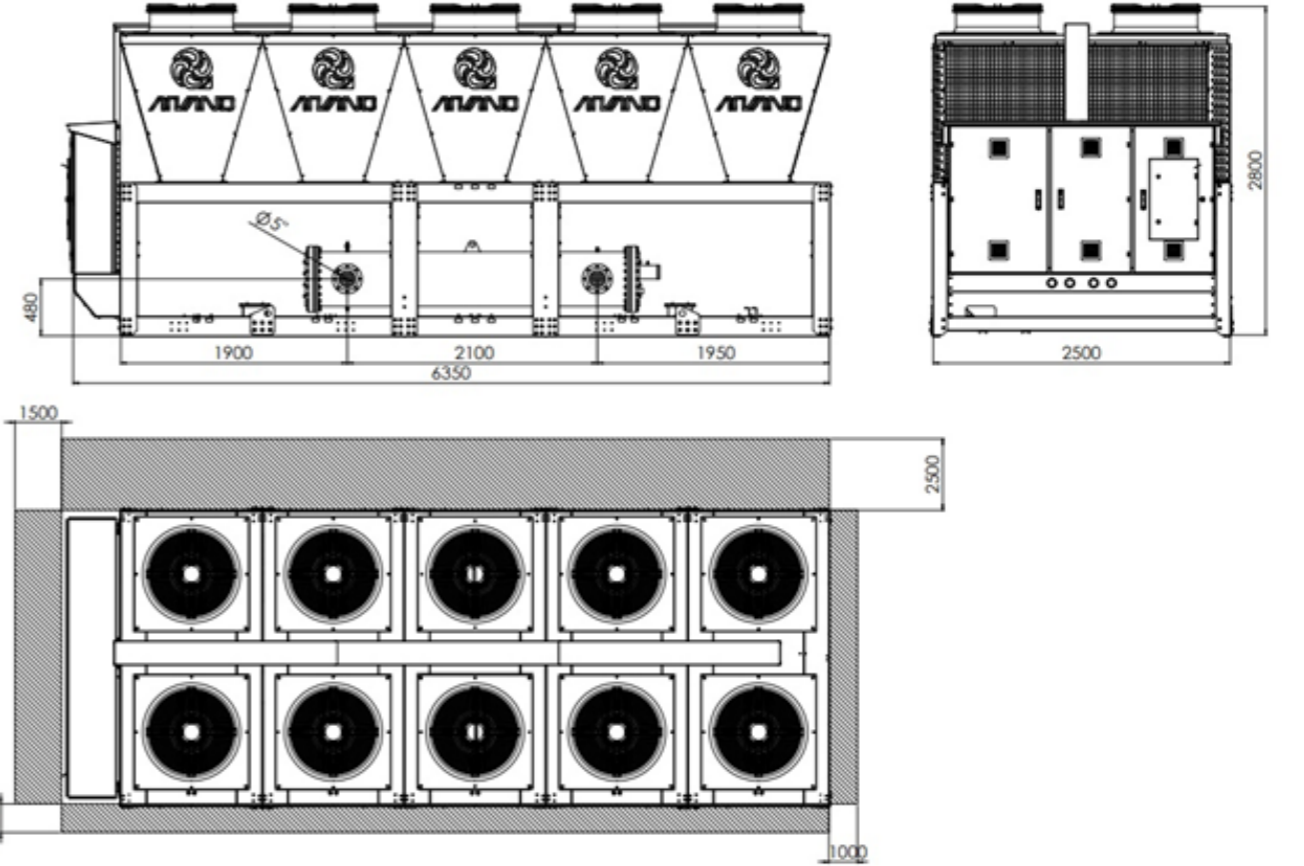

Models			
ACW20575HHSN	ACW20645HHSN	ACW20565SHLN	ACW20635SHLN

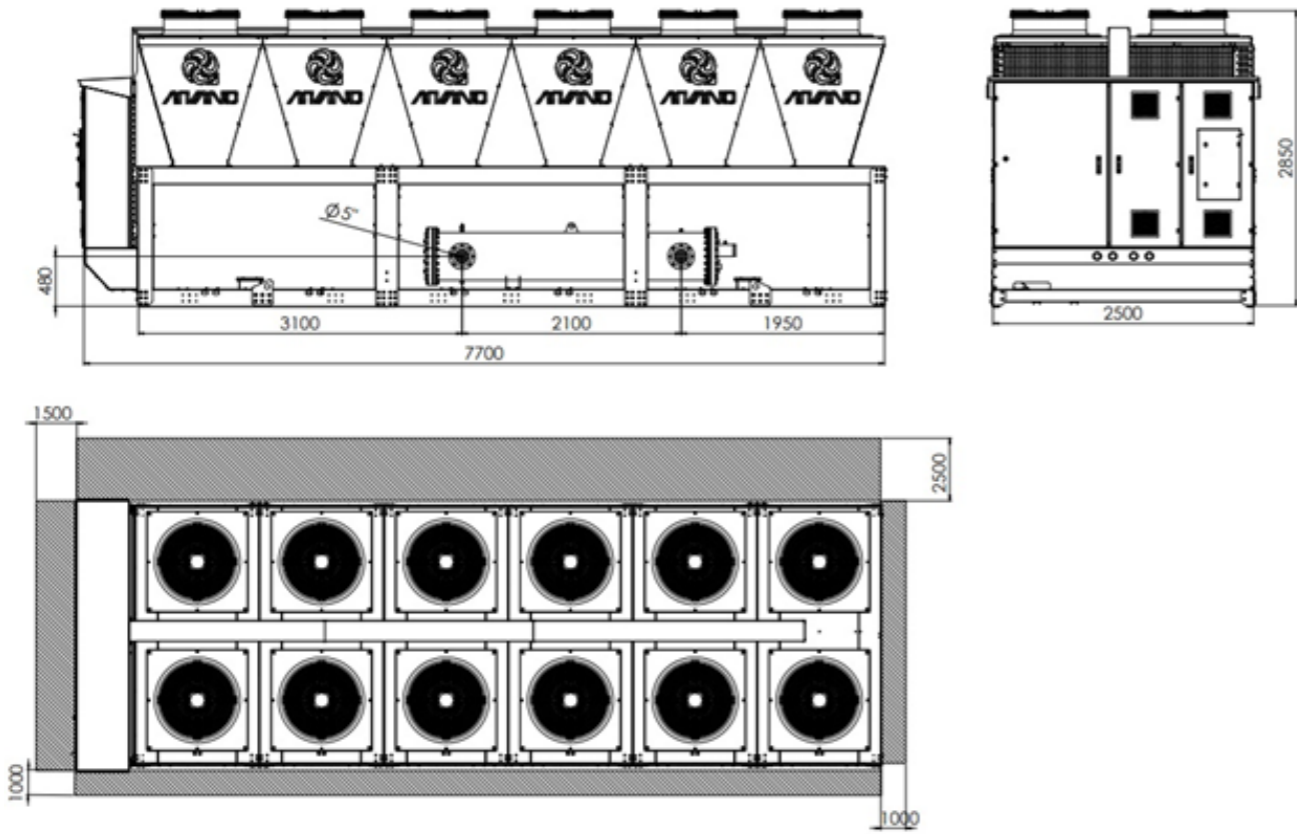

Models	
ACW20760SHSN	ACW20735SHLN

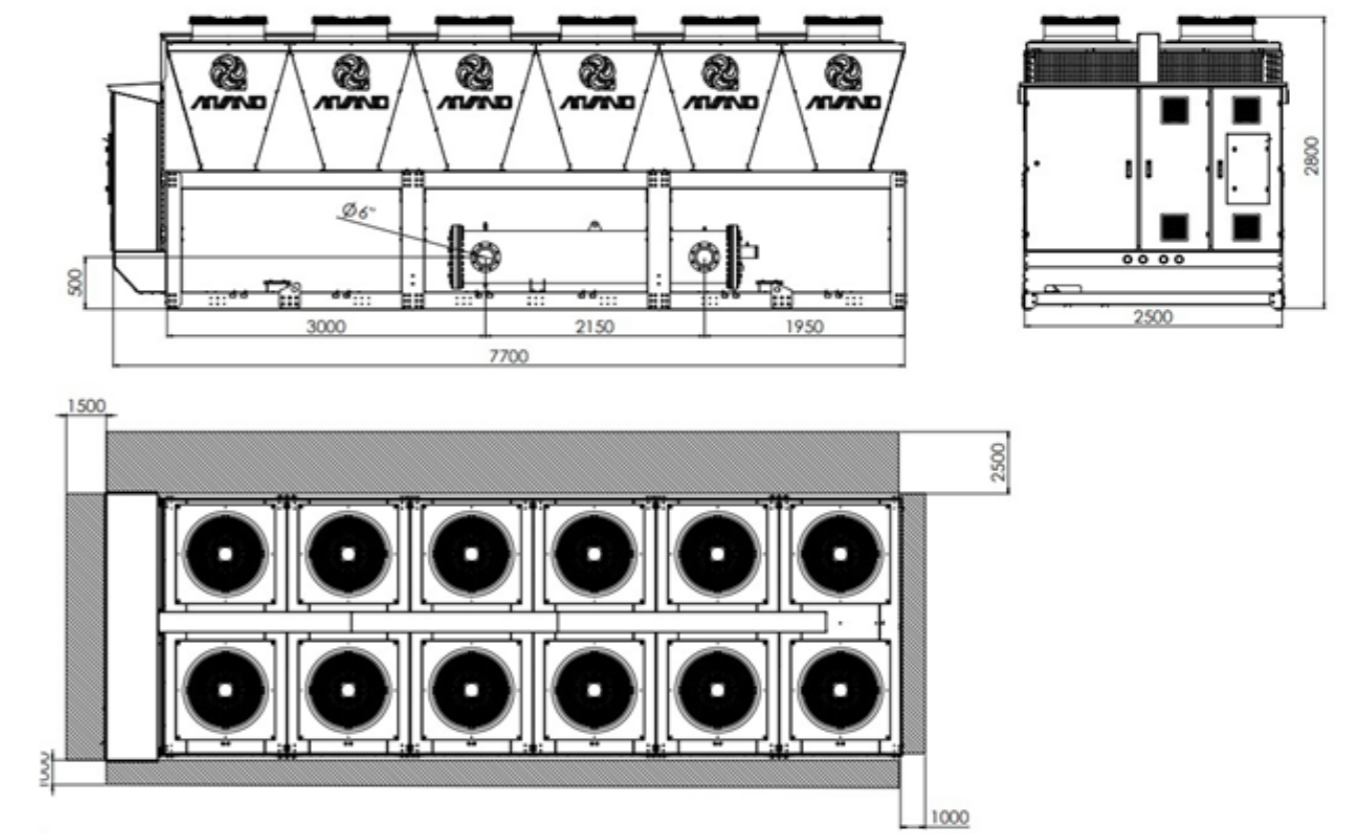

Models	
ACW20710SHSN	ACW20695SHLN

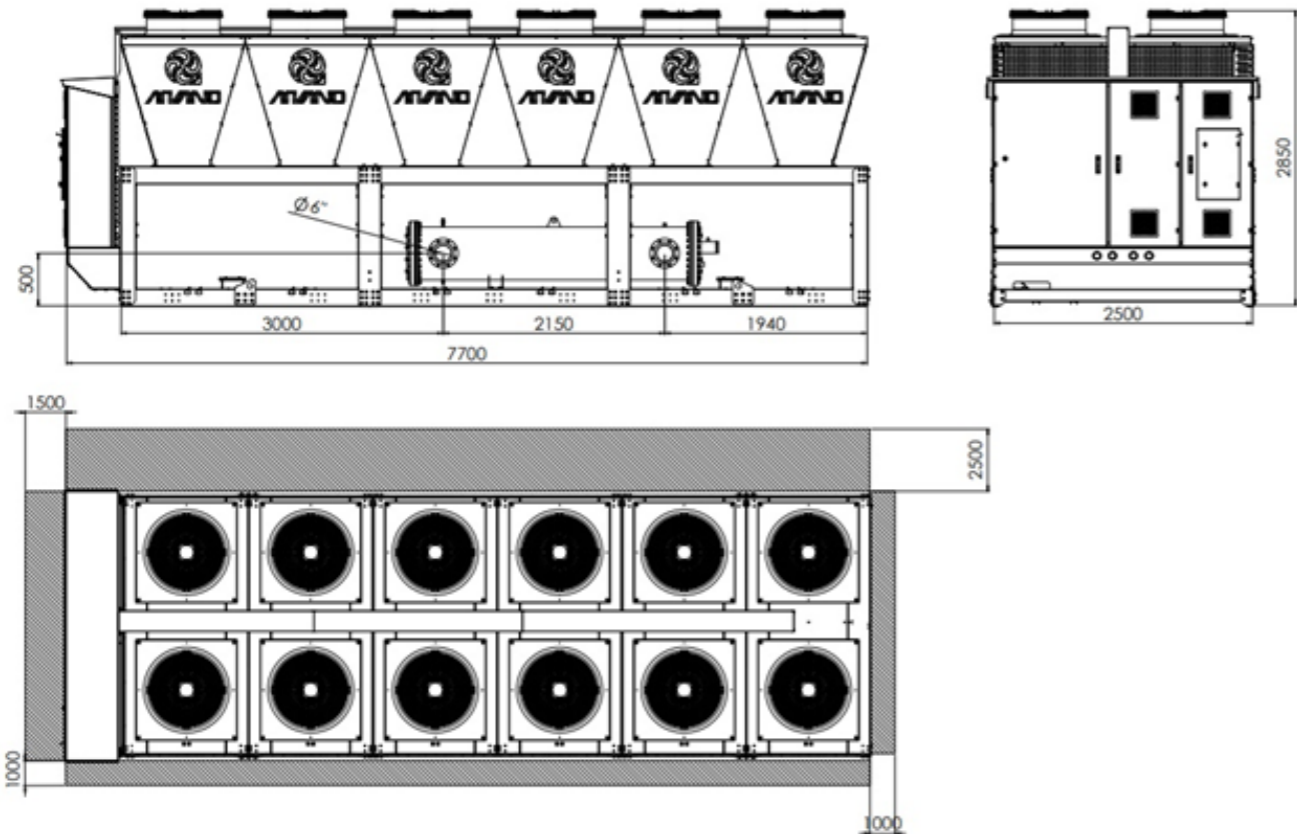

Models	
ACW20720HPSN	ACW20705SHLN

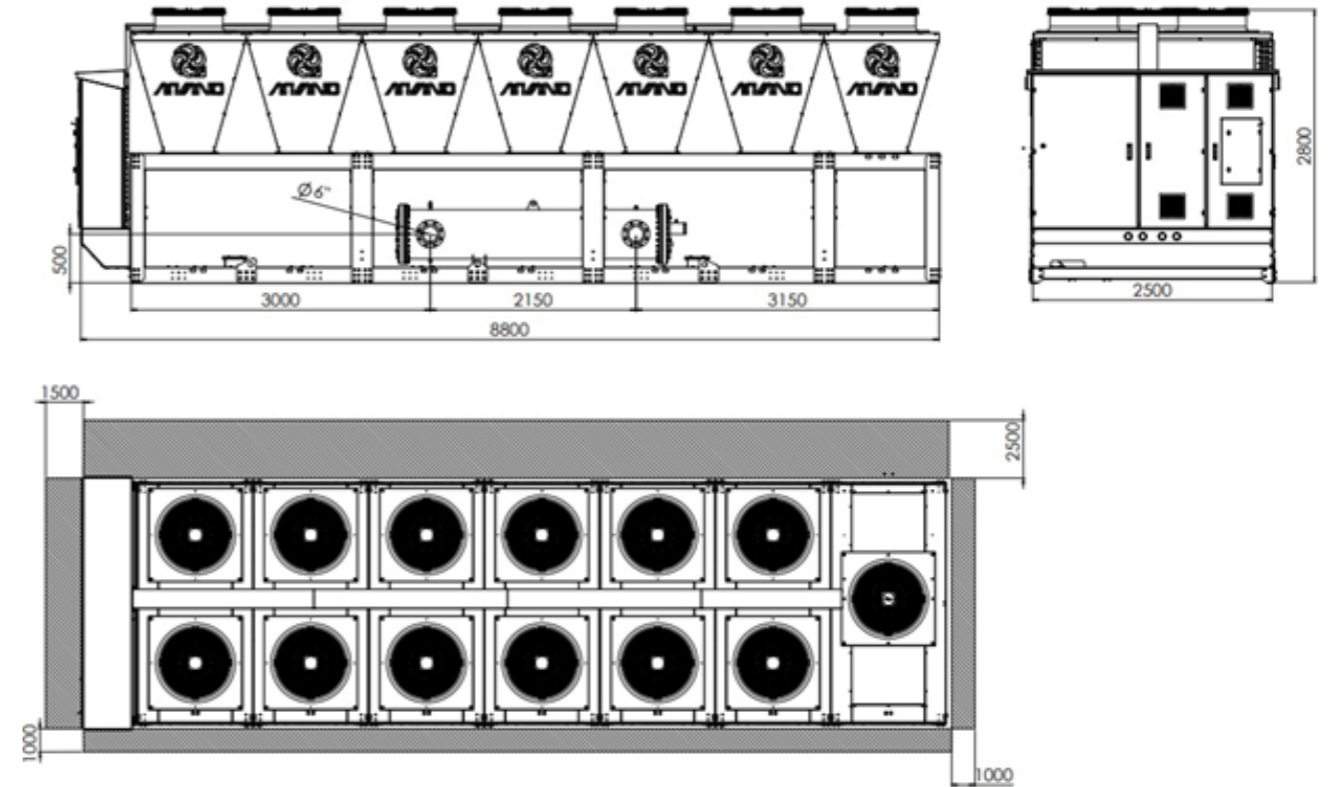

Models	
ACW20830SPSN	ACW20810SHLN

Models	
ACW20770HPSN	ACW20755SHLN

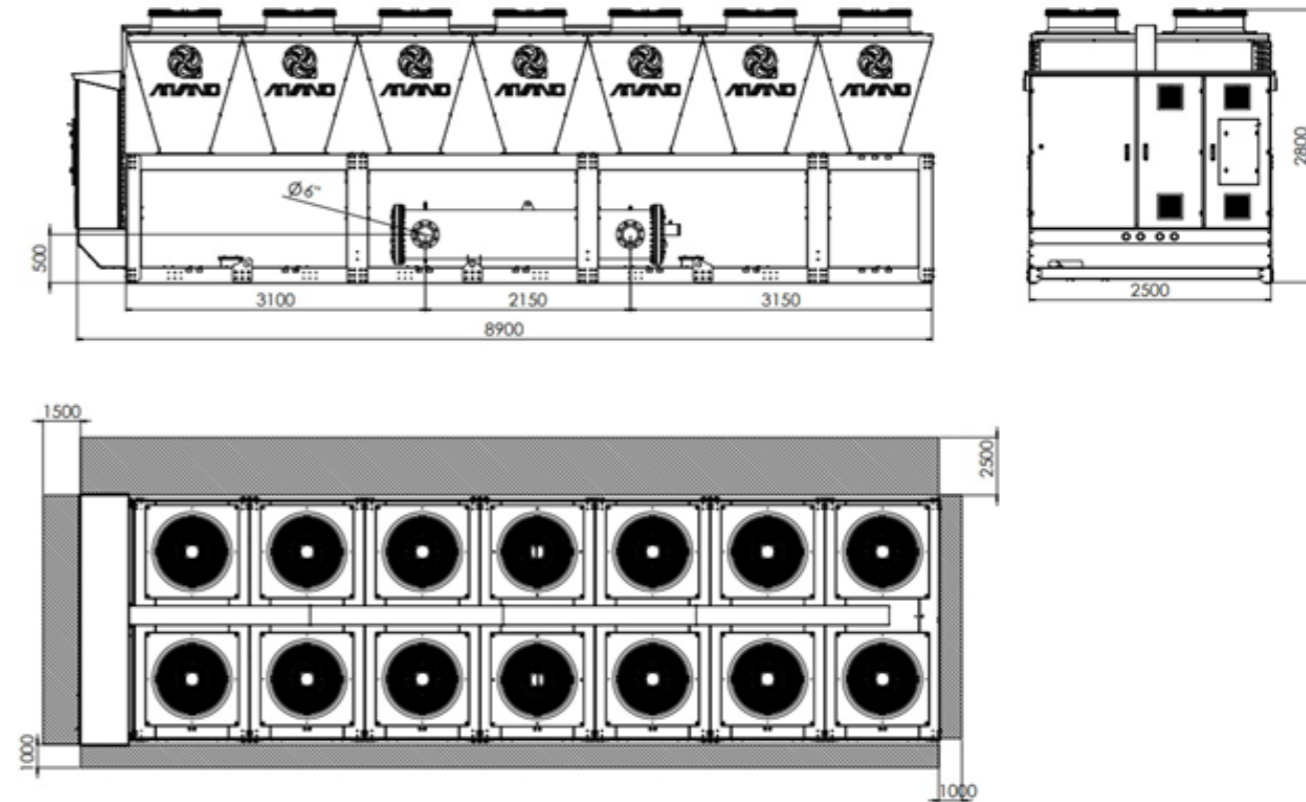
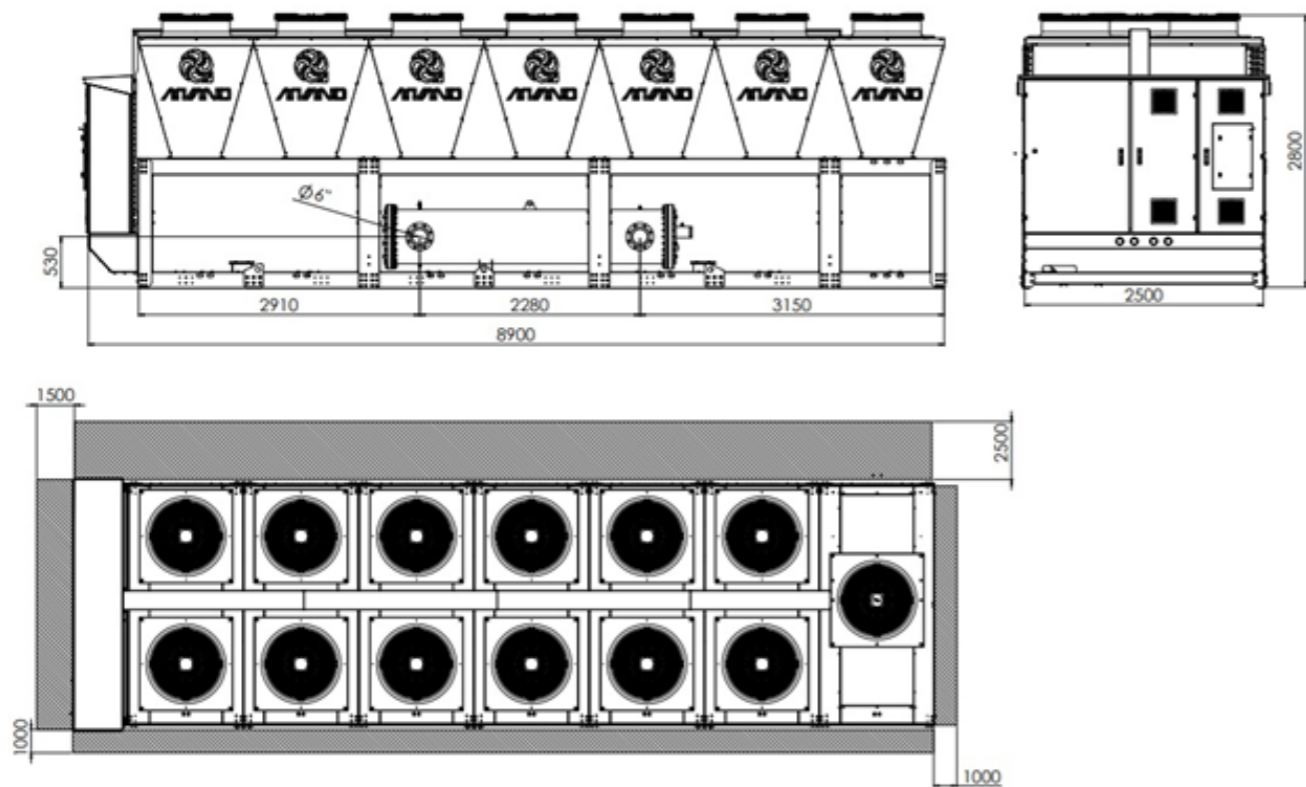

Models	
ACW20870SHSN	ACW20845MHLN

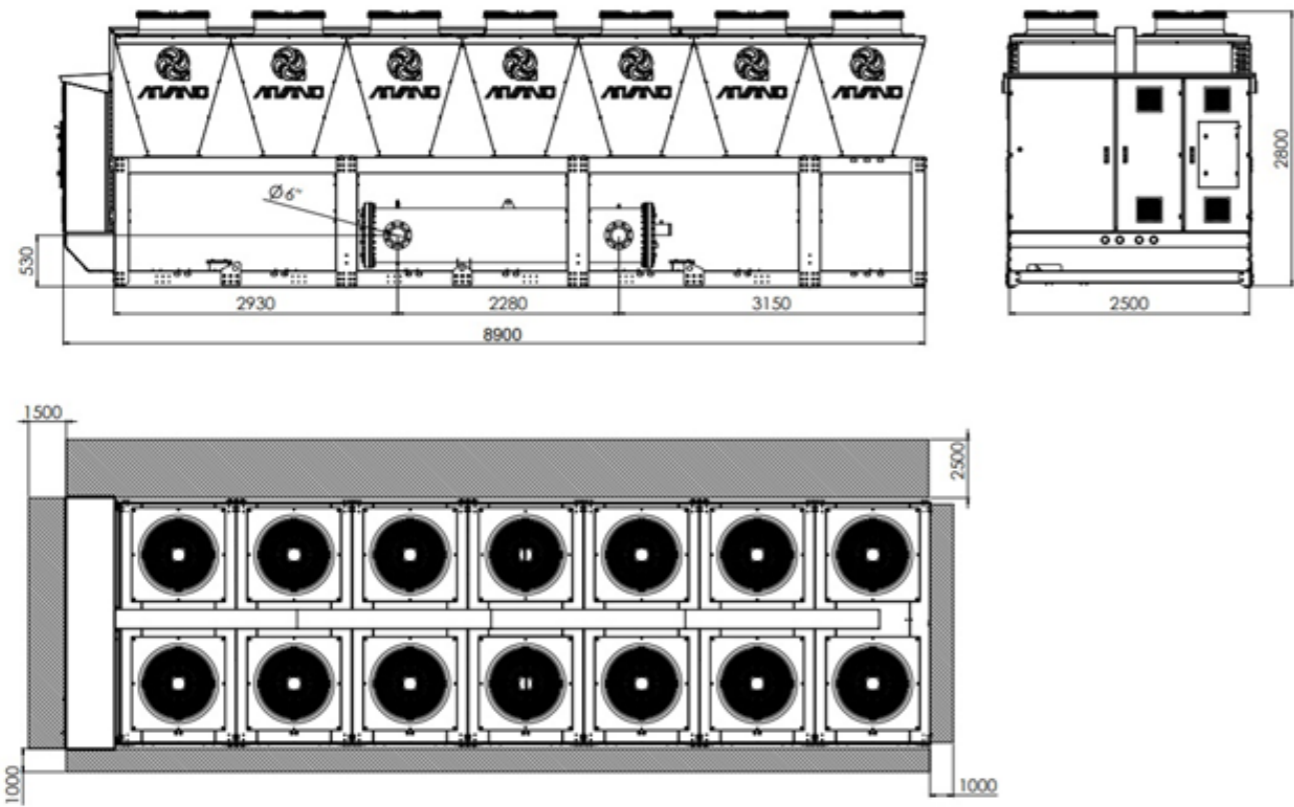

Models	
ACW20845HPSN	ACW20830SPLN

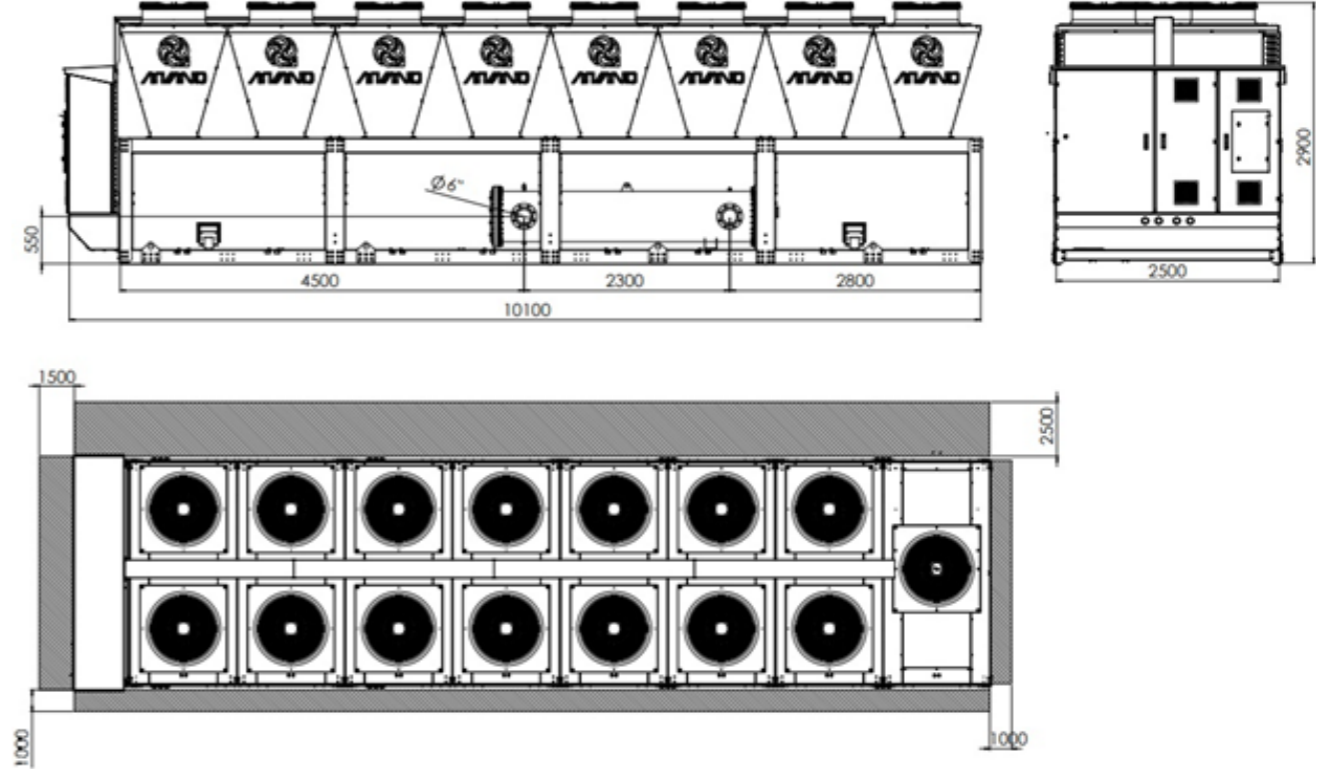

Models	
ACW20905HPSN	ACW20885SPLN

Models	
ACW21035SPSN	ACW21010SHLN

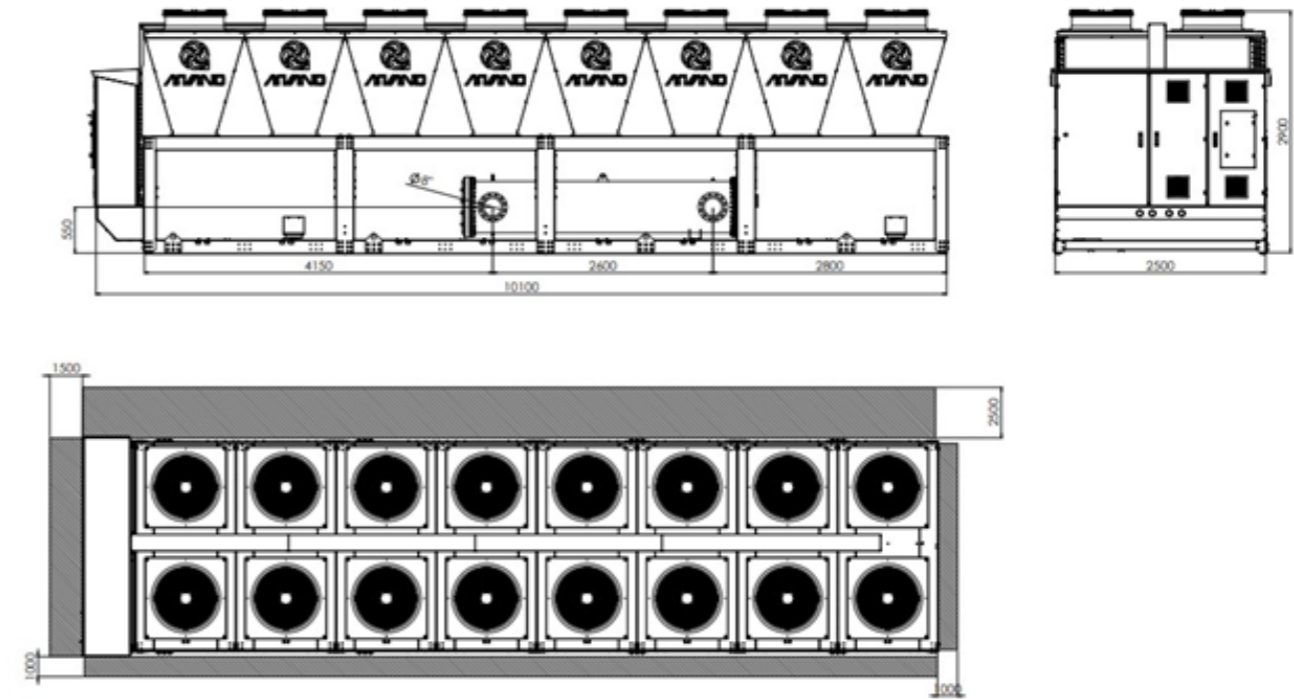
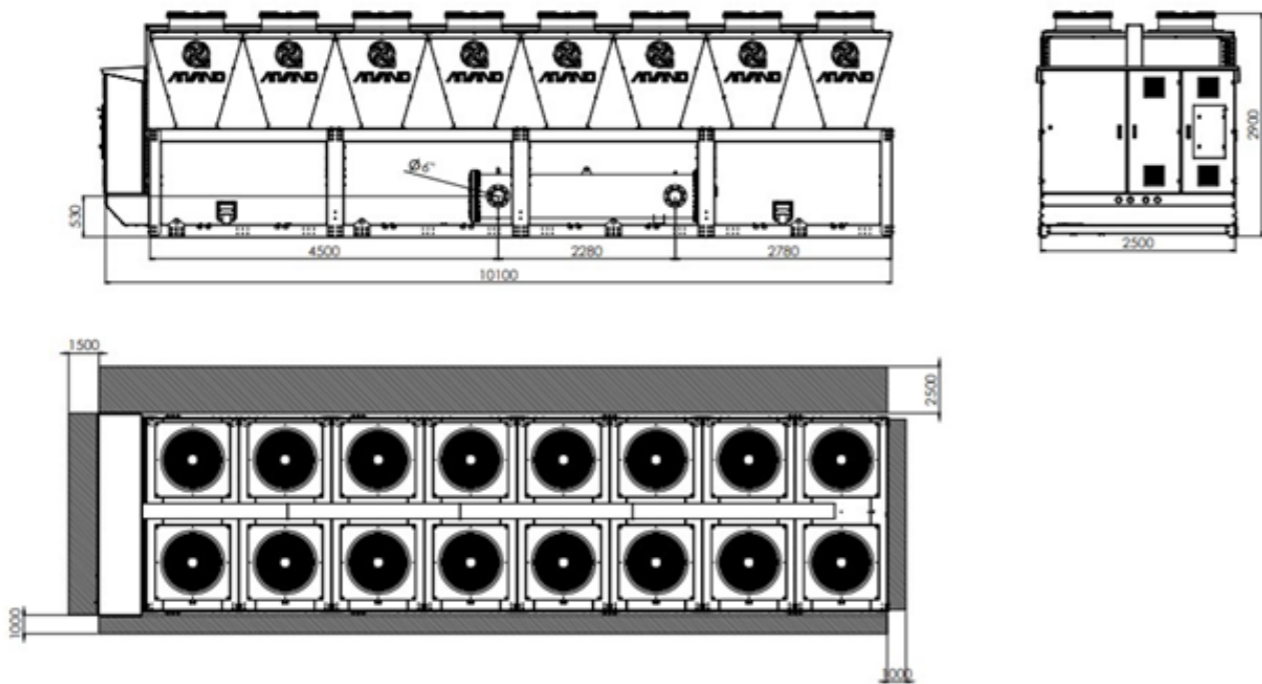

Models	
ACW21085SHSN	ACW21055MHLN

Models	
ACW21050HPSN	ACW21030SPLN

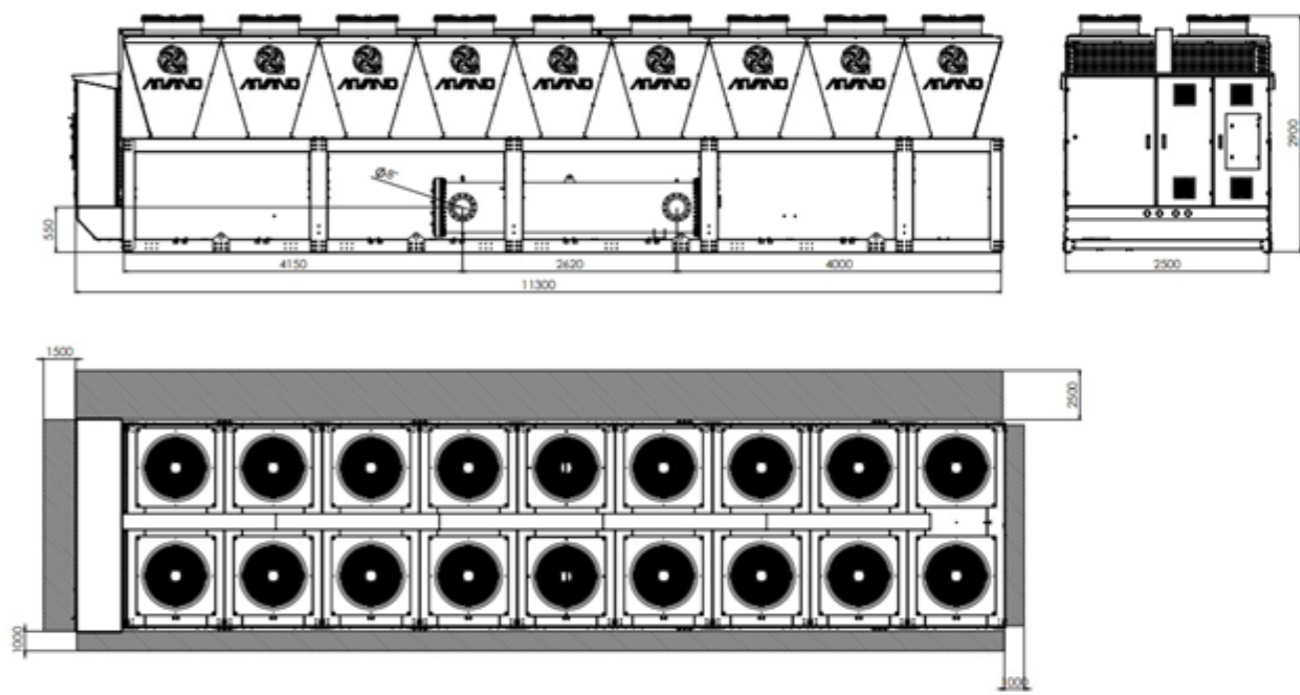
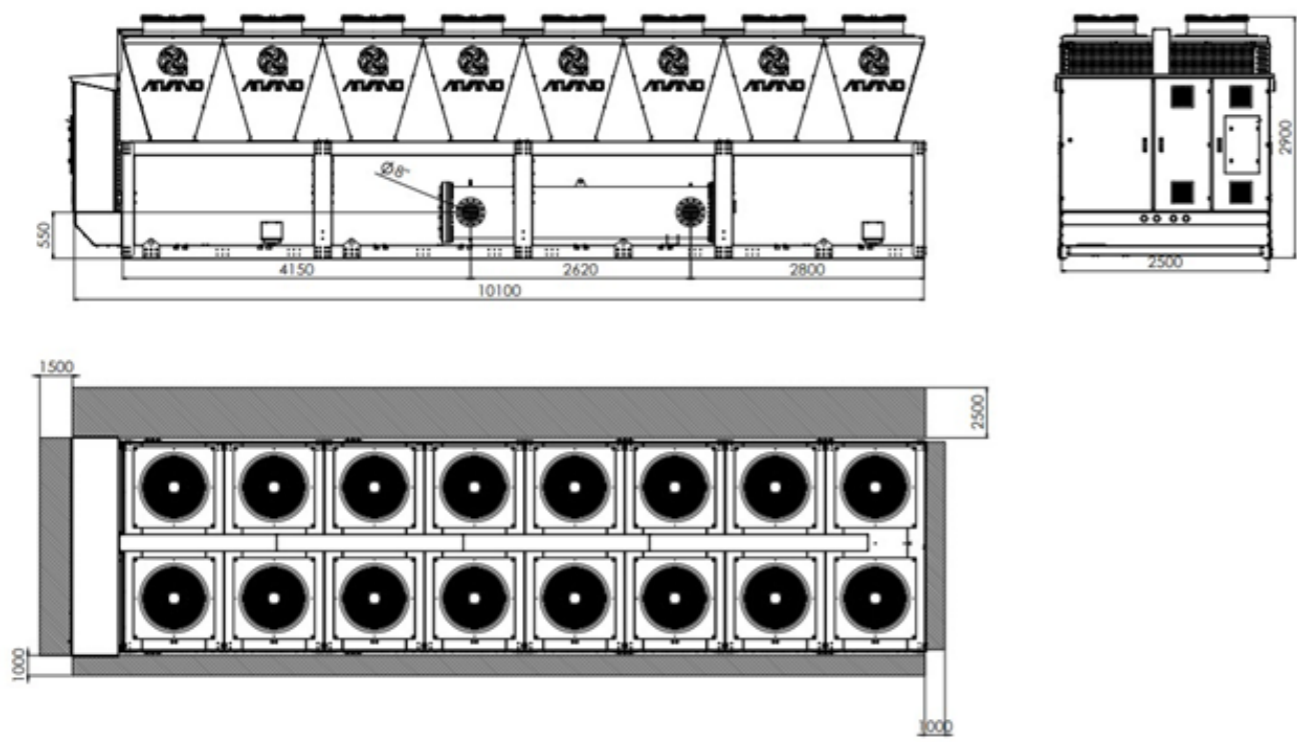

Models	
ACW31250HSSN	ACW31210SELN

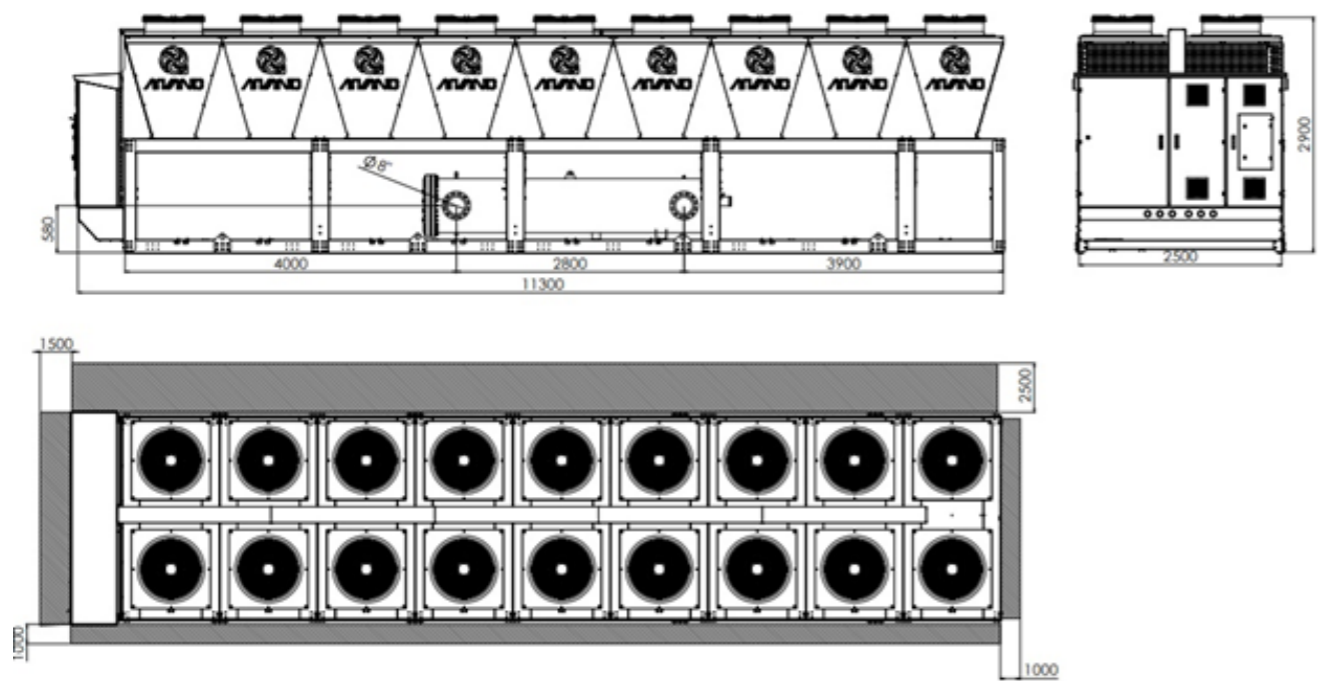

Models	
ACW31455HSSN	ACW31395SELN

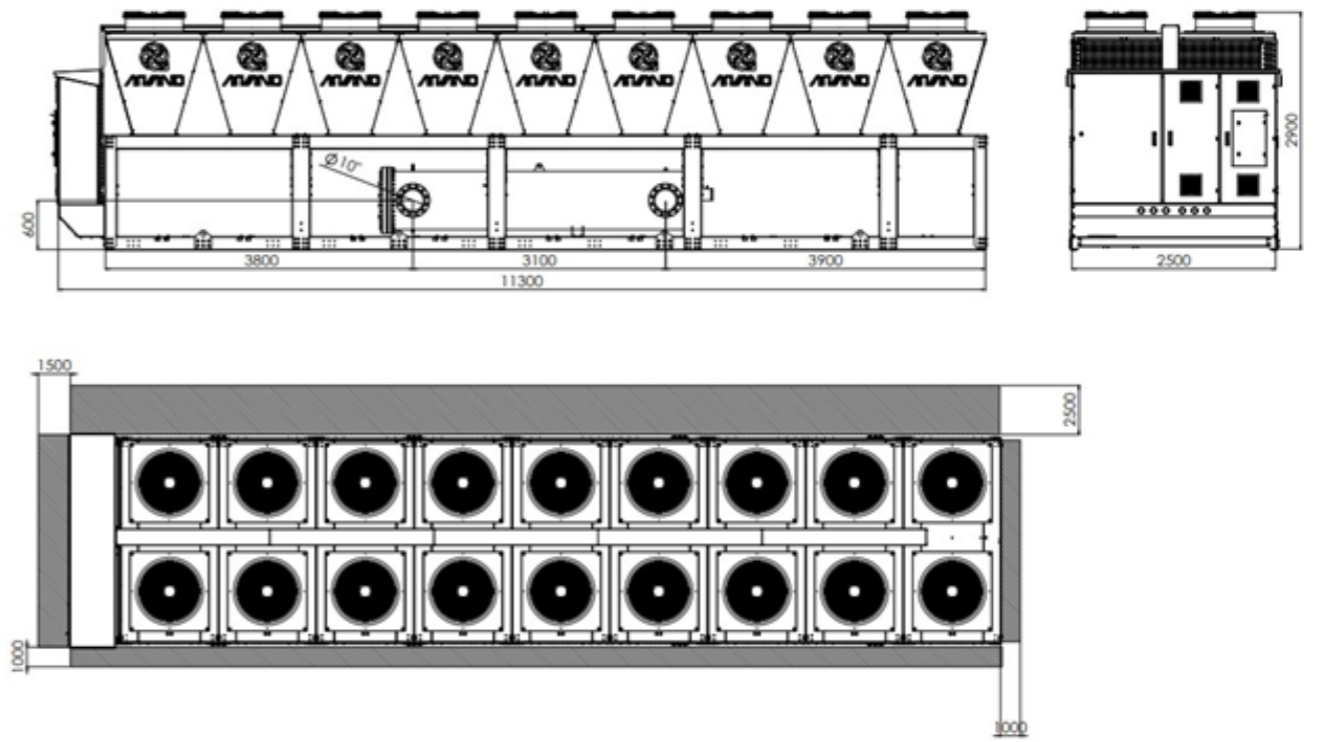

Models	
ACW21115HPSN	ACW21095SPLN

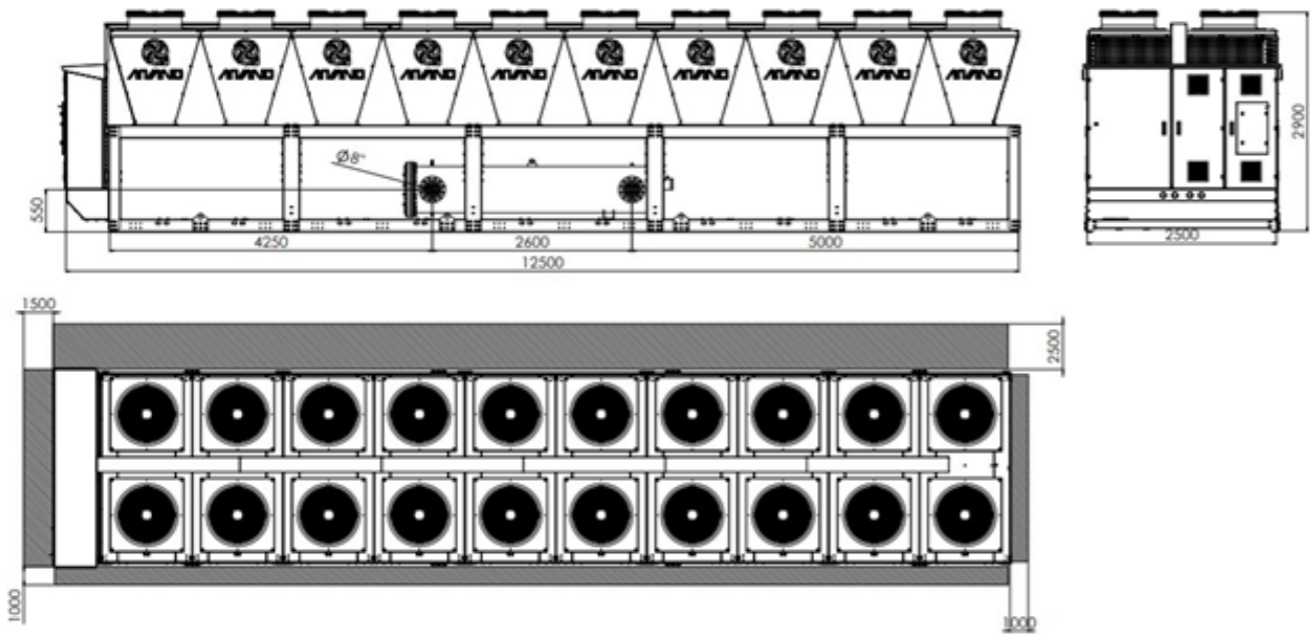

Models	
ACW31510SHSN	ACW31465MSLN

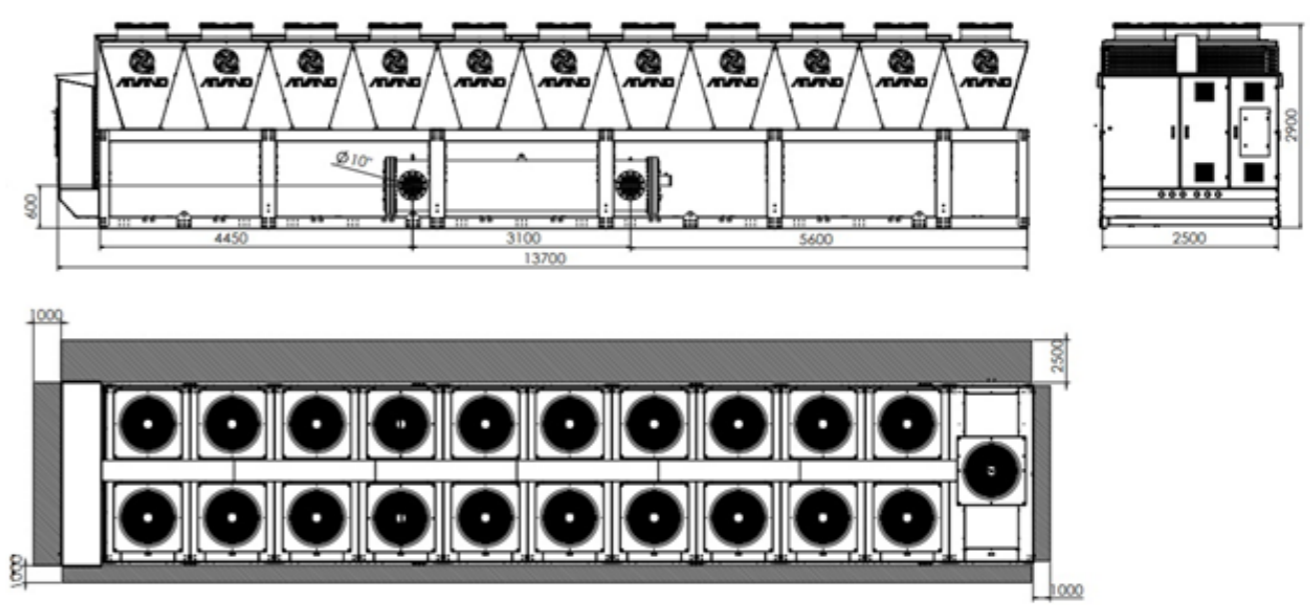

Models	
ACW31540SPSN	ACW31500SHLN

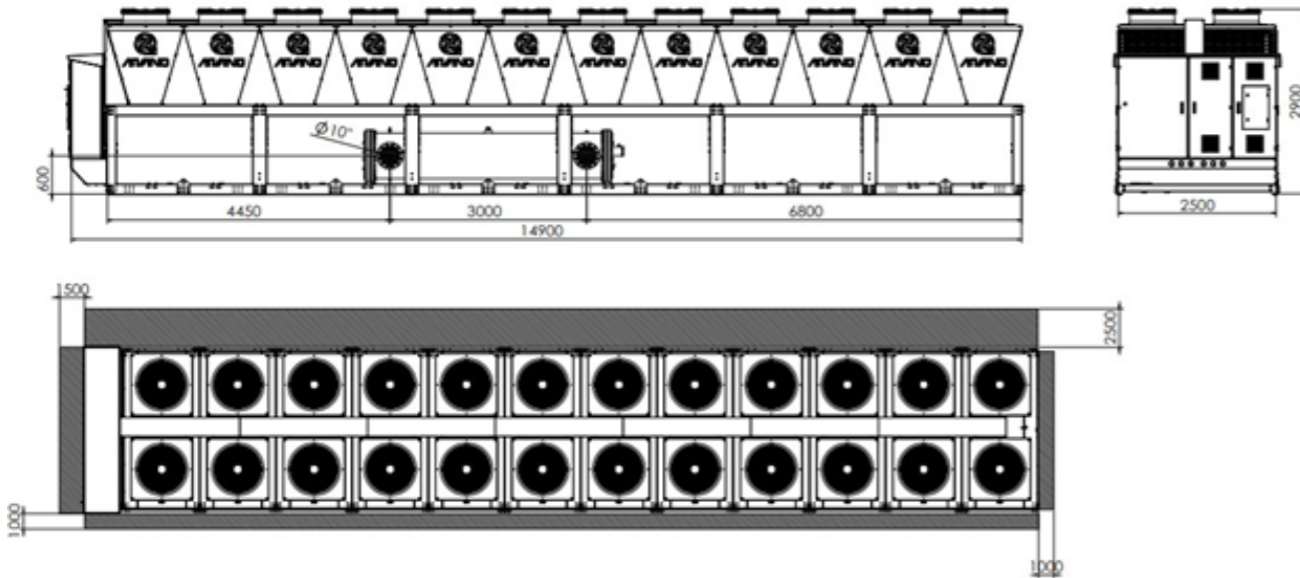

Standard Noise, Standard Ambient Temperature, 1-Compressor Units

Model: ACW10100SSSN																													
Ambient Temperature (°C)																													
CWT	30				35				40				43				46				50				52				MAT
	Q	P	WFR	Pd	Q	P	WFR	Pd	Q	P	WFR	Pd	Q	P	WFR	Pd	Q	P	WFR	Pd	Q	P	WFR	Pd	Q	P	WFR	Pd	
5	99.3	29.4	17.0	3.7	93.7	31.7	16.1	3.3	87.8	34.4	15.0	2.9	84.1	36.3	14.4	2.6	80.4	38.3	13.8	2.4								49	
6	102.8	29.7	17.6	3.9	97.0	32.0	16.6	3.5	90.9	34.8	15.6	3.1	87.2	36.6	14.9	2.8	83.4	38.7	14.3	2.6								49	
7	106.3	30.1	18.2	4.2	100.3	32.4	17.2	3.7	94.1	35.1	16.1	3.3	90.3	37.0	15.5	3.0	86.4	39.1	14.8	2.8								49	
8	109.9	30.4	18.8	4.5	103.8	32.8	17.8	4.0	97.4	35.5	16.7	3.5	93.5	37.4	16.0	3.3	89.5	39.5	15.3	3.0								49	
9	113.7	30.8	19.5	4.8	107.4	33.2	18.4	4.3	100.9	35.9	17.3	3.8	96.8	37.8	16.6	3.5	92.7	39.9	15.9	3.2								49	
10	117.6	31.2	20.2	5.1	111.1	33.6	19.0	4.6	104.4	36.4	17.9	4.0	100.2	38.3	17.2	3.7	96.0	40.4	16.5	3.4								48	

Model: ACW10110SSSN																													
Ambient Temperature (°C)																													
CWT	30				35				40				43				46				50				52				MAT
	Q	P	WFR	Pd	Q	P	WFR	Pd	Q	P	WFR	Pd	Q	P	WFR	Pd	Q	P	WFR	Pd	Q	P	WFR	Pd	Q	P	WFR	Pd	
5	111.3	32.7	19.1	4.6	104.7	35.5	17.9	4.1	97.8	38.6	16.8	3.6	93.6	40.7	16.0	3.3	89.3	42.9	15.3	3.0								49	
6	115.1	33.1	19.7	4.9	108.3	35.9	18.6	4.3	101.2	39.0	17.4	3.8	96.9	41.1	16.6	3.5	92.5	43.3	15.9	3.2								49	
7	118.9	33.5	20.4	5.2	111.9	36.3	19.2	4.6	104.7	39.5	17.9	4.1	100.3	41.5	17.2	3.7	95.8	43.8	16.4	3.4								49	
8	122.9	33.9	21.1	5.5	115.8	36.7	19.8	4.9	108.4	39.9	18.6	4.4	103.8	42.0	17.8	4.0	99.2	44.2	17.0	3.7								48	
9	127.0	34.3	21.8	5.9	119.7	37.2	20.5	5.3	112.1	40.4	19.2	4.6	107.4	42.5	18.4	4.3	102.7	44.7	17.6	3.9								48	
10	131.3	34.8	22.5	6.2	123.7	37.7	21.2	5.6	115.9	40.9	19.9	5.0	111.1	43.0	19.0	4.6	106.3	45.2	18.2	4.2								47	

Model: ACW10130SSSN																													
Ambient Temperature (°C)																													
CWT	30				35				40				43				46				50				52				MAT
	Q	P	WFR	Pd	Q	P	WFR	Pd	Q	P	WFR	Pd	Q	P	WFR	Pd	Q	P	WFR	Pd	Q	P	WFR	Pd	Q	P	WFR	Pd	
5	131.2	39.3	22.5	14.0	122.8	42.9	21.1	12.4	114.1	46.9	19.6	10.8	108.7	49.5	18.6	9.8	103.2	52.3	17.7	8.9								49	
6	135.8	39.9	23.3	14.9	127.2	43.5	21.8	13.2	118.2	47.5	20.3	11.5	112.7	50.2	19.3	10.5	107.1	53.0	18.4	9.6								48	
7	140.5	40.5	24.1	15.8	131.7	44.1	22.6	14.1	122.4	48.2	21.0	12.3	116.7	50.8	20.0	11.3	111.0	53.6	19.0	10.2								48	
8	145.3	41.1	24.9	16.8	136.2	44.7	23.4	15.0	126.7	48.8	21.7	13.1	120.9	51.5	20.7	12.0	115.0	54.3	19.7	10.9								48	
9	150.2	41.7	25.8	17.8	140.9	45.4	24.1	15.9	131.1	49.5	22.5	14.0	125.1	52.2	21.4	12.8	119.0	55.0	20.4	11.7								47	
10	155.2	42.3	26.6	18.9	145.6	46.0	25.0	16.9	135.6	50.2	23.2	14.9	129.4	52.9	22.2	13.7	123.2	55.8	21.1	12.5								47	

Model: ACW10150SSSN																													
Ambient Temperature (°C)																													
CWT	30				35				40				43				46				50				52				MAT
	Q	P	WFR	Pd	Q	P	WFR	Pd	Q	P	WFR	Pd	Q	P	WFR	Pd	Q	P	WFR	Pd	Q	P	WFR	Pd	Q	P	WFR	Pd	
5	150.7	44.5	25.8	17.9	141.5	48.4	24.2	16.0	131.8	52.8	22.6	14.1	125.8	55.7	21.6	13.0	119.7	58.8	20.5	11.8								49	
6	156.1	45.0	26.8	19.1	146.6	49.0	25.1	17.1	136.7	53.4	23.4	15.1	130.5	56.3	22.4	13.9	124.3	59.4	21.3	12.7								49	
7	161.6	45.6	27.7	20.3	151.9	49.6	26.0	18.2	141.7	54.0	24.3	16.1	135.4	56.9	23.2	14.8	128.9	60.1	22.1	13.6								49	
8	167.3	46.2	28.7	21.6	157.3	50.2	27.0	19.3	146.8	54.7	25.2	17.1	140.3	57.6	24.0	15.8	133.7	60.7	22.9	14.5								49	
9	173.1	46.8	29.7	22.9	162.8	50.8	27.9	20.6	152.0	55.3	26.1	18.2	145.3	58.3	24.9	16.8	138.5	61.4	23.7	15.4								49	
10	179.0	47.4	30.7	24.3	168.4	51.5	28.9	21.8	157.3	56.0	27.0	19.4	150.5	59.0	25.8	17.9	143.5	62.2	24.6	16.4								49	

Model: ACW10185SSSN																													
Ambient Temperature (°C)																													
CWT	30				35				40				43				46				50				52				MAT
	Q	P	WFR	Pd	Q	P	WFR	Pd	Q	P	WFR	Pd	Q	P	WFR	Pd	Q	P	WFR	Pd	Q	P	WFR	Pd	Q	P	WFR	Pd	
5	182.5	55.7	31.3	22.8	172.1	61.0	29.5	20.5	161.3	67.1	27.7	18.1	154.6	71.1	26.5	16.7	147.8	75.5	25.3	15.4								48	
6	188.9	56.5	32.4	24.3	178.2	61.8	30.6	21.8	167.1	68.0	28.7	19.4	160.3	72.1	27.5	17.9	153.3	76.5	26.3	16.5								48	
7	195.4	57.2	33.5	25.9	184.5	62.7	31.6	23.3	173.1	68.9	29.7	20.7	166.1	73.0	28.5	19.1	158.9	77.5	27.2	17.6								47	
8	202.0	58.0	34.6	27.5	190.8	63.5	32.7	24.8	179.2	69.8	30.7	22.0	172.0	74.0	29.5	20.4	164.7	78.6	28.2	18.8								47	
9	208.8	58.9	35.8	29.2	197.3	64.4	33.8	26.4	185.4	70.8	31.8	23.5	178.0	75.0	30.5	21.8	170.5	79.6	29.2	20.1								46	
10	215.7	59.7	37.0	31.0	203.9	65.3	35.0	28.0	191.7	71.8	32.9	25.0	184.2	76.1	31.6	23.2	176.5	80.7	30.3	21.4								46	

- Q: Cooling Capacity in kW
- P: Total Power Absorbed in kW
- WFR: Water Flow Rate in m3/hr.
- Pd: Water Pressure Drop in kPa
- CWT: Chilled Water Temperature in °C (ΔT = 5°C)
- MAT: Maximum Ambient Temperature in °C
- NOTES:
 - Data on grey background: unit switched to non-silenced operation
 - Waterflow and pressure drop on heat exchangers calculated with 5°C of delta T
 - Interpolation between rating is permissible but extrapolation is not.
 - When the external air temperature is higher than the "MAT" the chiller doesn't stop but the "unloading" system capacity control is activated.

Standard Noise, Standard Ambient Temperature, 1-Compressor Units

Model: ACW10215SSSN																													
Ambient Temperature (°C)																													
CWT	30				35				40				43				46				50				52				MAT
	Q	P	WFR	Pd	Q	P	WFR	Pd	Q	P	WFR	Pd	Q	P	WFR	Pd	Q	P	WFR	Pd	Q	P	WFR	Pd	Q	P	WFR	Pd	
5	210.7	62.0	36.1	29.7	199.2	67.7	34.2	26.8	187.3	74.3	32.1	23.9	179.8	78.7	30.8	22.2	172.3	83.4	29.5	20.5									49
6	218.1	62.8	37.4	31.7	206.4	68.6	35.4	28.6	194.1	75.2	33.3	25.6	186.5	79.6	32.0	23.8	178.8	84.4	30.6	21.9									49
7	225.8	63.6	38.7	33.8	213.8	69.4	36.6	30.5	201.2	76.1	34.5	27.3	193.4	80.6	33.2	25.4	185.5	85.4	31.8	23.5									49
8	233.6	64.4	40.0	35.9	221.2	70.3	37.9	32.5	208.4	77.0	35.7	29.1	200.4	81.5	34.4	27.1	192.3	86.4	33.0	25.1									49
9	241.5	65.2	41.4	38.2	228.9	71.1	39.2	34.6	215.7	78.0	37.0	31.0	207.5	82.5	35.6	28.9	199.2	87.5	34.2	26.8									49
10	249.6	66.0	42.8	40.6	236.7	72.1	40.6	36.8	223.2	79.0	38.3	33.0	214.8	83.6	36.8	30.8	206.3	88.6	35.4	28.6									48

Model: ACW10245SSSN																													
Ambient Temperature (°C)																													
CWT	30				35				40				43				46				50				52				MAT
	Q	P	WFR	Pd	Q	P	WFR	Pd	Q	P	WFR	Pd	Q	P	WFR	Pd	Q	P	WFR	Pd	Q	P	WFR	Pd	Q	P	WFR	Pd	
5	243.8	72.1	41.8	24.9	229.2	78.9	39.3	22.3	214.1	86.6	36.7	19.6	204.9	91.8	35.1	18.0	195.6	97.5	33.5	16.5									48
6	252.1	73.0	43.2	26.5	237.2	79.9	40.7	23.7	221.6	87.8	38.0	20.9	212.1	93.0	36.4	19.2	202.5	98.7	34.7	17.6									48
7	260.7	74.0	44.7	28.2	245.3	81.0	42.1	25.2	229.3	88.9	39.3	22.3	219.5	94.2	37.6	20.5	209.6	99.9	35.9	18.8									47
8	269.3	75.1	46.2	29.9	253.5	82.1	43.5	26.8	237.0	90.1	40.6	23.7	226.9	95.4	38.9	21.8	216.7	101.2	37.2	20.0									47
9	278.1	76.1	47.7	31.7	261.8	83.2	44.9	28.4	244.8	91.3	42.0	25.1	234.5	96.6	40.2	23.2	224.0	102.5	38.4	21.3									46
10	287.0	77.2	49.2	33.6	270.3	84.3	46.3	30.1	252.8	92.5	43.3	26.7	242.2	97.9	41.5	24.6	231.4	103.8	39.7	22.6									46

Model: ACW10280SSSN																													
Ambient Temperature (°C)																													
CWT	30				35				40				43				46				50				52				MAT
	Q	P	WFR	Pd	Q	P	WFR	Pd	Q	P	WFR	Pd	Q	P	WFR	Pd	Q	P	WFR	Pd	Q	P	WFR	Pd	Q	P	WFR	Pd	
5	277.9	80.5	47.6	14.1	261.7	88.1	44.9	12.6	245.0	96.8	42.0	11.2	234.7	102.7	40.2	10.3	224.2	109.0	38.4	9.5									48
6	287.3	81.6	49.3	15.0	270.7	89.3	46.4	13.5	253.5	98.1	43.5	11.9	242.9	104.0	41.6	11.0	232.2	110.4	39.8	10.1									48
7	296.9	82.7	50.9	16.0	279.9	90.5	48.0	14.3	262.2	99.5	45.0	12.7	251.4	105.4	43.1	11.7	240.3	111.9	41.2	10.8									47
8	306.7	83.9	52.6	17.0	289.2	91.8	49.6	15.2	271.1	100.8	46.5	13.5	260.0	106.9	44.6	12.5	248.7	113.4	42.6	11.5									47
9	316.7	85.1	54.3	18.0	298.7	93.1	51.2	16.2	280.2	102.3	48.0	14.3	268.7	108.4	46.1	13.3	257.1	114.9	44.1	12.2									46
10	326.9	86.4	56.0	19.1	308.4	94.5	52.9	17.1	289.4	103.7	49.6	15.2	277.7	109.9	47.6	14.1	265.8	116.5	45.6	13.0									46

Model: ACW10310SSSN																													
Ambient Temperature (°C)																													
CWT	30				35				40				43				46				50				52				MAT
	Q	P	WFR	Pd	Q	P	WFR	Pd	Q	P	WFR	Pd	Q	P	WFR	Pd	Q	P	WFR	Pd	Q	P	WFR	Pd	Q	P	WFR	Pd	
5	309.9	92.7	53.1	17.3	291.9	101.5	50.0	15.5	273.2	111.6	46.8	13.7	261.7	118.3	44.9	12.6	250.0	125.6	42.9	11.6									48
6	320.4	93.9	54.9	18.4	301.9	102.8	51.8	16.5	282.7	113.0	48.5	14.6	270.9	119.8	46.4	13.5	258.9	127.2	44.4	12.4									47
7	331.2	95.2	56.8	19.5	312.2	104.2	53.5	17.5	292.5	114.5	50.1	15.5	280.3	121.4	48.1	14.4	268.0	128.8	45.9	13.2									47
8	342.1	96.6	58.6	20.7	322.6	105.6	55.3	18.6	302.3	116.1	51.8	16.5	289.9	123.0	49.7	15.3	277.2	130.5	47.5	14.1									47
9	353.2	97.9	60.6	22.0	333.2	107.1	57.1	19.8	312.4	117.6	53.6	17.5	299.7	124.7	51.4	16.2	286.7	132.2	49.1	15.0									46
10	364.6	99.3	62.5	23.3	344.0	108.6	59.0	20.9	322.7	119.3	55.3	18.6	309.6	126.4	53.1	17.3	296.3	134.0	50.8	15.9									46

- Q: Cooling Capacity in kW
- P: Total Power Absorbed in kW
- WFR: Water Flow Rate in m³/hr.
- Pd: Water Pressure Drop in kPa
- CWT: Chilled Water Temperature in °C (ΔT = 5°C)
- MAT: Maximum Ambient Temperature in °C
- NOTES:

- Data on grey background: unit switched to non-silenced operation
- Waterflow and pressure drop on heat exchangers calculated with 5°C of delta T
- Interpolation between rating is permissible but extrapolation is not.
- When the external air temperature is higher than the "MAT" the chiller doesn't stop but the "unloading" system capacity control is activated.

Standard Noise, Standard Ambient Temperature, 2-Compressor Units

Model: ACW20205SHSN																													
Ambient Temperature (°C)																													
CWT	30				35				40				43				46				50				52				MAT
	Q	P	WFR	Pd	Q	P	WFR	Pd	Q	P	WFR	Pd	Q	P	WFR	Pd	Q	P	WFR	Pd	Q	P	WFR	Pd	Q	P	WFR	Pd	
5	202.3	59.1	34.7	17.6	190.7	63.7	32.7	15.7	178.6	69.1	30.6	13.8	171.1	72.9	29.3	12.7	163.5	77.0	28.0	11.6									49
6	209.4	59.8	35.9	18.8	197.5	64.5	33.9	16.8	185.1	69.9	31.7	14.8	177.4	73.6	30.4	13.6	169.6	77.8	29.1	12.4									49
7	216.7	60.6	37.2	20.0	204.5	65.2	35.1	17.9	191.7	70.7	32.9	15.8	183.8	74.4	31.5	14.6	175.8	78.6	30.1	13.4									49
8	224.1	61.3	38.4	21.3	211.5	66.0	36.3	19.1	198.4	71.5	34.0	16.9	190.3	75.3	32.6	15.6	182.1	79.5	31.2	14.3									49
9	231.6	62.1	39.7	22.7	218.6	66.8	37.5	20.4	205.2	72.3	35.2	18.1	196.9	76.1	33.8	16.7	188.5	80.3	32.3	15.3									49
10	239.3	62.8	41.0	24.1	226.0	67.6	38.7	21.7	212.2	73.1	36.4	19.2	203.7	76.9	34.9	17.8	195.0	81.2	33.4	16.4									49

Model: ACW20230SHSN																													
Ambient Temperature (°C)																													
CWT	30				35				40				43				46				50				52				MAT
	Q	P	WFR	Pd	Q	P	WFR	Pd	Q	P	WFR	Pd	Q	P	WFR	Pd	Q	P	WFR	Pd	Q	P	WFR	Pd	Q	P	WFR	Pd	
5	227.0	65.9	38.9	21.9	213.4	71.5	36.6	19.4	199.2	77.7	34.2	17.1	190.6	81.8	32.7	15.7	181.8	86.1	31.2	14.3									49
6	234.8	66.7	40.3	23.3	220.8	72.3	37.9	20.7	206.3	78.6	35.4	18.2	197.4	82.7	33.8	16.8	188.4	87.1	32.3	15.3									49
7	242.8	67.5	41.6	24.8	228.4	73.1	39.2	22.1	213.5	79.5	36.6	19.5	204.4	83.6	35.0	17.9	195.2	88.0	33.5	16.4									48
8	250.8	68.3	43.0	26.3	236.1	74.0	40.5	23.5	220.8	80.4	37.9	20.7	211.5	84.5	36.3	19.1	202.1	89.0	34.6	17.5									48
9	259.0	69.2	44.4	27.9	243.9	74.9	41.8	25.0	228.3	81.3	39.1	22.1	218.7	85.5	37.5	20.4	209.0	90.0	35.8	18.7									48
10	267.4	70.0	45.8	29.5	251.9	75.8	43.2	26.5	235.9	82.3	40.4	23.5	226.1	86.5	38.8	21.7	216.2	91.0	37.1	19.9									47

Model: ACW20250SESN																													
Ambient Temperature (°C)																													
CWT	30				35				40				43				46				50				52				MAT
	Q	P	WFR	Pd	Q	P	WFR	Pd	Q	P	WFR	Pd	Q	P	WFR	Pd	Q	P	WFR	Pd	Q	P	WFR	Pd	Q	P	WFR	Pd	
5	251.8	80.6	43.2	26.5	235.4	88.1	40.3	23.4	218.3	96.4	37.4	20.3	207.8	101.8	35.6	18.5	197.1	107.6	33.8	16.7									47
6	260.6	81.8	44.7	28.2	243.6	89.3	41.8	24.9	226.1	97.7	38.8	21.7	215.3	103.2	36.9	19.8	204.3	109.0	35.0	17.9									47
7	269.5	83.0	46.2	30.0	252.1	90.6	43.2	26.5	234.0	99.0	40.1	23.1	222.9	104.5	38.2	21.1	211.6	110.3	36.3	19.1									46
8	278.5	84.2	47.7	31.8	260.6	91.8	44.7	28.2	242.0	100.4	41.5	24.6	230.6	105.9	39.5	22.5	219.0	1											

Standard Noise, Standard Ambient Temperature, 2-Compressor Units

Model: ACW20335SSSN																													
Ambient Temperature (°C)																													
CWT	30				35				40				43				46				50				52				MAT
	Q	P	WFR	Pd	Q	P	WFR	Pd	Q	P	WFR	Pd	Q	P	WFR	Pd	Q	P	WFR	Pd	Q	P	WFR	Pd	Q	P	WFR	Pd	
5	332.9	100.1	57.1	19.7	313.5	109.3	53.7	17.7	293.1	119.8	50.3	15.6	280.6	126.8	48.1	14.4	267.7	134.3	45.9	13.2									48
6	344.6	101.4	59.1	21.0	324.6	110.7	55.7	18.8	303.8	121.3	52.1	16.7	290.9	128.4	49.9	15.4	277.7	135.9	47.6	14.1									48
7	356.5	102.7	61.1	22.4	336.1	112.2	57.6	20.1	314.7	122.9	53.9	17.8	301.4	129.9	51.7	16.4	287.9	137.6	49.4	15.1									47
8	368.7	104.1	63.2	23.8	347.7	113.6	59.6	21.4	325.8	124.4	55.8	19.0	312.2	131.6	53.5	17.5	298.3	139.3	51.1	16.1									47
9	381.2	105.5	65.3	25.3	359.6	115.1	61.6	22.7	337.1	126.1	57.8	20.2	323.2	133.3	55.4	18.7	309.0	141.0	53.0	17.2									46
10	393.9	107.0	67.5	26.9	371.8	116.7	63.7	24.2	348.7	127.7	59.8	21.5	334.4	135.0	57.3	19.9	319.9	142.8	54.8	18.3									46

Model: ACW20375SHSN																															
Ambient Temperature (°C)																															
CWT	30				35				40				43				46				50				52				MAT		
	Q	P	WFR	Pd	Q	P	WFR	Pd	Q	P	WFR	Pd	Q	P	WFR	Pd	Q	P	WFR	Pd	Q	P	WFR	Pd	Q	P	WFR	Pd		Q	P
5	371.9	108.0	63.8	30.7	351.6	118.1	60.3	27.7	330.4	129.7	56.6	24.7	317.3	137.5	54.4	22.9	303.8	145.9	52.1	21.2										49	
6	385.0	109.4	66.0	32.8	364.0	119.6	62.4	29.5	342.5	131.3	58.7	26.4	329.0	139.2	56.4	24.5	315.2	147.7	54.0	22.7										49	
7	398.3	110.8	68.3	34.7	377.0	121.2	64.6	31.5	354.8	133.0	60.8	28.1	341.0	141.0	58.5	26.2	326.9	149.5	56.0	24.2										49	
8	411.9	112.3	70.6	37.0	390.1	122.8	66.9	33.5	367.3	134.8	63.0	30.0	353.2	142.8	60.6	27.9	338.8	151.5	58.1	25.9										48	
9	425.8	113.9	73.0	39.4	403.4	124.4	69.2	35.6	380.1	136.5	65.2	32.0	365.7	144.7	62.7	29.8	351.0	153.4	60.2	27.6										48	
10	440.0	115.4	75.4	41.8	417.1	126.1	71.5	37.9	393.2	138.4	67.4	34.0	378.5	146.6	64.9	31.7	363.4	155.4	62.3	29.4										48	

Model: ACW20400SSSN																															
Ambient Temperature (°C)																															
CWT	30				35				40				43				46				50				52				MAT		
	Q	P	WFR	Pd	Q	P	WFR	Pd	Q	P	WFR	Pd	Q	P	WFR	Pd	Q	P	WFR	Pd	Q	P	WFR	Pd	Q	P	WFR	Pd		Q	P
5	393.4	117.7	67.4	34.0	371.8	128.7	63.7	30.7	349.2	141.4	59.9	27.3	335.2	149.9	57.5	25.4	320.9	159.1	55.0	23.4										49	
6	407.1	119.2	69.8	36.2	385.0	130.4	66.0	32.7	361.9	143.2	62.0	29.2	347.5	151.7	59.6	27.1	332.9	161.0	57.1	25.0										49	
7	421.1	120.8	72.2	38.6	398.6	132.0	68.3	34.8	374.8	145.0	64.3	31.1	360.1	153.6	61.7	28.9	345.1	163.0	59.2	26.8										49	
8	435.4	122.4	74.6	41.0	412.2	133.8	70.7	37.1	388.0	146.9	66.5	33.2	373.0	155.6	63.9	30.9	357.6	165.1	61.3	28.6										48	
9	450.1	124.0	77.2	43.6	426.3	135.5	73.1	39.5	401.5	148.8	68.8	35.3	386.1	157.6	66.2	32.9	370.4	167.2	63.5	30.5										48	
10	465.0	125.7	79.7	46.3	440.7	137.3	75.5	41.9	415.3	150.7	71.2	37.6	399.6	159.7	68.5	35.0	383.5	169.3	65.7	32.5										48	

Model: ACW20425SSSN																															
Ambient Temperature (°C)																															
CWT	30				35				40				43				46				50				52				MAT		
	Q	P	WFR	Pd	Q	P	WFR	Pd	Q	P	WFR	Pd	Q	P	WFR	Pd	Q	P	WFR	Pd	Q	P	WFR	Pd	Q	P	WFR	Pd		Q	P
5	420.9	124.0	72.1	38.5	398.3	135.5	68.3	34.8	374.7	148.6	64.2	31.1	360.0	157.4	61.7	28.9	345.0	167.0	59.1	26.7										49	
6	435.6	125.5	74.7	41.1	412.5	137.1	70.7	37.1	388.3	150.4	66.6	33.2	373.3	159.3	64.0	30.9	357.9	168.9	61.4	28.6										49	
7	450.7	127.1	77.3	43.7	427.1	138.7	73.2	39.6	402.3	152.2	69.0	35.5	386.9	161.1	66.3	33.0	371.2	170.9	63.6	30.6										49	
8	466.1	128.7	79.9	46.5	441.9	140.4	75.8	42.1	416.5	154.0	71.4	37.8	400.8	163.1	68.7	35.2	384.7	172.9	66.0	32.7										49	
9	481.9	130.3	82.6	49.5	457.1	142.2	78.4	44.9	431.1	155.9	73.9	40.3	415.0	165.1	71.1	37.6	398.6	175.0	68.3	34.9										49	
10	498.0	132.0	85.4	52.6	472.6	144.0	81.0	47.7	446.0	157.9	76.5	42.9	429.6	167.1	73.6	40.0	412.7	177.1	70.8	37.2										48	

Model: ACW20480SHSN																															
Ambient Temperature (°C)																															
CWT	30				35				40				43				46				50				52				MAT		
	Q	P	WFR	Pd	Q	P	WFR	Pd	Q	P	WFR	Pd	Q	P	WFR	Pd	Q	P	WFR	Pd	Q	P	WFR	Pd	Q	P	WFR	Pd		Q	P
5	473.6	131.4	81.2	42.8	447.3	143.3	76.7	38.6	419.8	157.1	72.0	34.4	402.8	166.3	69.0	31.9	385.5	176.2	66.1	29.4										49	
6	490.6	133.1	84.1	45.7	463.6	145.1	79.5	41.2	435.3	159.0	74.6	36.7	417.8	168.3	71.6	34.1	400.0	178.3	68.6	31.5										49	
7	508.0	134.8	87.1	48.7	480.2	147.0	82.3	43.9	451.1	161.0	77.3	39.2	433.1	170.4	74.3	36.4	414.9	180.5	71.1	33.6										49	
8	524.9	136.5	90.0	51.7	496.5	148.8	85.1	46.7	466.6	163.0	80.0	41.7	448.2	172.4	76.8	38.7	429.5	182.6	73.6	35.8										48	
9	542.2	138.3	93.0	54.8	513.0	150.7	87.9	49.6	482.5	165.0	82.7	44.3	463.6	174.5	79.5	41.2	444.3	184.8	76.2	38.1										48	
10	559.9	140.1	96.0	58.2	529.9	152.7	90.8	52.6	498.6	167.1	85.5	47.0	479.2	176.7	82.2	43.8	459.5	187.1	78.8	40.5										47	

- Q; Cooling Capacity in kW
- P; Total Power Absorbed in kW
- WFR; Water Flow Rate in m3/hr.
- Pd; Water Pressure Drop in kPa
- CWT; Chilled Water Temperature in °C (ΔT = 5°C)
- MAT; Maximum Ambient Temperature in °C
- NOTES:

- Data on grey background: unit switched to non-silenced operation
- Waterflow and pressure drop on heat exchangers calculated with 5°C of delta T
- Interpolation between rating is permissible but extrapolation is not.
- When the external air temperature is higher than the "MAT" the chiller doesn't stop but the "unloading" system capacity control is activated.

Standard Noise, Standard Ambient Temperature, 2-Compressor Units

Model: ACW20500SSSN																															
Ambient Temperature (°C)																															
CWT	30				35				40				43				46				50				52				MAT		
	Q	P	WFR	Pd	Q	P	WFR	Pd	Q	P	WFR	Pd	Q	P	WFR	Pd	Q	P	WFR	Pd	Q	P	WFR	Pd	Q	P	WFR	Pd		Q	P
5	494.4	145.0	84.8	46.3	465.1	158.6	79.7	41.4	434.6	174.2	74.5	36.6	415.9	184.6	71.3	33.8	397.0	195.9	68.1	31.0										48	
6	511.6	146.9	87.7	49.3	481.4	160.7	82.5	44.1	450.0	176.5	77.1	39.0	430.7	187.0	73.8	36.0	411.2	198.4	70.5	33.1										48	
7	529.2	149.0	90.7	52.5	498.1	162.9	85.4	47.0	465.7	178.9	79.8	41.5	445.8	189.5	76.4	38.4	425.8	201.0	73.0	35.3										47	
8	546.3	151.0	93.6	55.6	514.4	165.1	88.2	49.8	481.1	181.2	82.5	44.1	460.6	191.9	79.0	40.7	440.0	203.5	75.4	37.4										47	
9	563.7	153.1	96.6	58.9	530.9	167.3	91.0	52.8	496.7	183.6	85.1	46.7	475.7	194.4	81.6	43.2	454.5	206.1	77.9	39.7										46	
10	581.4	155.2	99.7	62.4	547.7	169.6	93.9	55.9	512.6	186.0	87.9	49.5	491.0	197.0	84.2	45.7	469.2	208.7	80.4	42.1										46	

Model: ACW20565SHSN																															
Ambient Temperature (°C)																															
CWT	30				35				40				43				46				50				52				MAT		
	Q	P	WFR	Pd	Q	P	WFR	Pd	Q	P	WFR	Pd	Q	P	WFR	Pd	Q	P	WFR	Pd	Q	P	WFR	Pd	Q	P	WFR	Pd		Q	P
5	557.2	160.5	95.5	43.1	525.9	175.2	90.2	38.8	493.3	192.2	84.6	34.6	473.2	203.5	81.1	32.0	452.6	215.8	77.6	29.6										49	
6	576.4	162.5	98.8	45.9	544.3	177.4	93.3	41.3	510.8	194																					

Standard Noise, High Ambient Temperature, 3-Compressor Units

Model: ACW31250HSSN																													
Ambient Temperature (°C)																													
CWT	30				35				40				43				46				50				52				MAT
	Q	P	WFR	Pd	Q	P	WFR	Pd	Q	P	WFR	Pd	Q	P	WFR	Pd	Q	P	WFR	Pd	Q	P	WFR	Pd	Q	P	WFR	Pd	
5	1243.8	379.7	213.2	77.2	1172.6	411.7	201.0	69.0	1098.3	447.0	188.3	60.9	1052.6	470.0	180.4	56.1	1006.4	494.6	172.5	51.5	944.3	530.1	161.9	45.6					51
6	1284.3	384.7	220.2	82.0	1211.5	417.0	207.7	73.4	1135.4	452.7	194.6	64.9	1088.7	475.9	186.6	59.9	1041.4	500.8	178.5	55.0	977.7	536.5	167.6	48.7					51
7	1325.3	389.8	227.2	87.0	1251.0	422.5	214.5	78.0	1173.3	458.5	201.1	69.1	1125.4	482.0	192.9	63.8	1077.0	507.0	184.6	58.6	1011.8	543.1	173.5	52.0					50
8	1366.3	394.8	234.2	92.2	1290.4	427.9	221.2	82.8	1211.1	464.3	207.6	73.4	1162.2	488.0	199.2	67.8	1112.7	513.3	190.7	62.4	1046.0	549.7	179.3	55.5					50
9	1407.8	399.9	241.3	97.5	1330.5	433.4	228.1	87.7	1249.5	470.2	214.2	77.9	1199.6	494.2	205.6	72.1	1149.0	519.7	197.0	66.4									49
10	1449.8	405.2	248.5	103.0	1371.1	439.0	235.1	92.8	1288.6	476.3	220.9	82.5	1237.6	500.5	212.2	76.5	1185.9	526.3	203.3	70.5									49

Model: ACW31455HSSN																													
Ambient Temperature (°C)																													
CWT	30				35				40				43				46				50				52				MAT
	Q	P	WFR	Pd	Q	P	WFR	Pd	Q	P	WFR	Pd	Q	P	WFR	Pd	Q	P	WFR	Pd	Q	P	WFR	Pd	Q	P	WFR	Pd	
5	1441.2	422.5	247.1	62.0	1363.5	461.5	233.7	56.0	1282.0	503.6	219.8	49.9	1231.2	530.2	211.1	46.4	1179.3	557.7	202.2	42.8	1108.3	595.9	190.0	38.2					51
6	1487.3	428.3	255.0	65.7	1408.0	467.8	241.4	59.4	1324.5	510.3	227.1	53.0	1272.6	537.2	218.2	49.3	1219.5	565.0	209.1	45.6	1146.9	603.5	196.6	40.7					50
7	1534.1	434.2	263.0	69.5	1453.1	474.2	249.1	62.9	1367.8	517.2	234.5	56.3	1314.7	544.4	225.4	52.3	1260.4	572.4	216.1	48.4	1186.1	611.2	203.3	43.3					50
8	1581.3	440.3	271.1	73.5	1498.7	480.8	256.9	66.6	1411.6	524.2	242.0	59.6	1357.4	551.7	232.7	55.5	1301.9	580.0	223.2	51.4									49
9	1629.0	446.4	279.3	77.7	1545.0	487.4	264.9	70.5	1456.1	531.4	249.6	63.2	1400.8	559.1	240.1	58.8	1344.1	587.7	230.4	54.5									49
10	1677.1	452.6	287.5	82.0	1591.8	494.2	272.9	74.4	1501.3	538.7	257.4	66.8	1444.8	566.6	247.7	62.3	1387.0	595.5	237.8	57.7									48

- Q; Cooling Capacity in kW
 - P; Total Power Absorbed in kW
 - WFR; Water Flow Rate in m3/hr.
 - Pd; Water Pressure Drop in kPa
 - CWT; Chilled Water Temperature in °C (ΔT = 5°C)
 - MAT; Maximum Ambient Temperature in °C
- NOTES:
- Data on grey background: unit switched to non-silenced operation
 - Waterflow and pressure drop on heat exchangers calculated with 5°C of delta T
 - Interpolation between rating is permissible but extrapolation is not.
 - When the external air temperature is higher than the "MAT" the chiller doesn't stop but the "unloading" system capacity control is activated.

Low Noise, Medium and Standard Ambient Temperature, 1-Compressor Units

Model: ACW10100SSLN																													
Ambient Temperature (°C)																													
CWT	30				35				40				43				46				50				52				MAT
	Q	P	WFR	Pd	Q	P	WFR	Pd	Q	P	WFR	Pd	Q	P	WFR	Pd	Q	P	WFR	Pd	Q	P	WFR	Pd	Q	P	WFR	Pd	
5	97.7	28.8	16.7	3.6	92.0	31.3	15.8	3.1	86.0	34.1	14.7	2.7	82.3	36.1	14.1	2.5	78.6	38.3	13.5	2.3									49
6	101.0	29.2	17.3	3.8	95.1	31.6	16.3	3.4	89.0	34.5	15.3	2.9	85.2	36.5	14.6	2.7	81.4	38.8	14.0	2.4									49
7	104.3	29.6	17.9	4.0	98.3	32.0	16.9	3.6	92.1	35.0	15.8	3.2	88.2	37.0	15.1	2.9	84.3	39.2	14.4	2.6									48
8	107.9	30.0	18.5	4.3	101.7	32.5	17.4	3.8	95.3	35.4	16.3	3.4	91.3	37.4	15.7	3.1	87.3	39.7	15.0	2.8									48
9	111.5	30.4	19.1	4.6	105.1	32.9	18.0	4.1	98.5	35.9	16.9	3.6	94.5	37.9	16.2	3.3	90.3	40.1	15.5	3.0									47
10	115.2	30.8	19.7	4.9	108.6	33.3	18.6	4.4	101.9	36.3	17.5	3.9	97.7	38.4	16.7	3.6	93.4	40.6	16.0	3.3									47

Model: ACW10110SSLN																													
Ambient Temperature (°C)																													
CWT	30				35				40				43				46				50				52				MAT
	Q	P	WFR	Pd	Q	P	WFR	Pd	Q	P	WFR	Pd	Q	P	WFR	Pd	Q	P	WFR	Pd	Q	P	WFR	Pd	Q	P	WFR	Pd	
5	109.0	32.5	18.7	4.4	102.3	35.4	17.5	3.9	95.4	38.6	16.3	3.4	91.1	40.8	15.6	3.1	86.9	43.1	14.9	2.8									47
6	112.6	32.9	19.3	4.7	105.7	35.8	18.1	4.2	98.6	39.1	16.9	3.6	94.3	41.3	16.2	3.3	89.9	43.6	15.4	3.0									47
7	116.2	33.3	19.9	5.0	109.2	36.3	18.7	4.4	101.9	39.6	17.5	3.9	97.5	41.8	16.7	3.5	93.0	44.1	15.9	3.2									47
8	120.0	33.8	20.6	5.3	112.8	36.8	19.3	4.7	105.4	40.1	18.1	4.1	100.8	42.3	17.3	3.8	96.2	44.6	16.5	3.5									46
9	124.0	34.3	21.2	5.6	116.5	37.3	20.0	5.0	108.9	40.6	18.7	4.4	104.2	42.8	17.9	4.0	99.5	45.2	17.1	3.7									46
10	127.9	34.7	21.9	6.0	120.3	37.8	20.6	5.3	112.5	41.2	19.3	4.7	107.7	43.4	18.5	4.3	106.3	45.2	18.2	4.2									45

Model: ACW10125SELN																													
Ambient Temperature (°C)																													
CWT	30				35				40				43				46				50				52				MAT
	Q	P	WFR	Pd	Q	P	WFR	Pd	Q	P	WFR	Pd	Q	P	WFR	Pd	Q	P	WFR	Pd	Q	P	WFR	Pd	Q	P	WFR	Pd	
5	127.3	39.8	21.8	13.2	118.8	43.6	20.4	11.7	110.0	47.8	18.9	10.1	104.6	50.6	17.9	9.1	99.2	53.5	17.0	8.2									46
6	131.7	40.4	22.6	14.1	122.9	44.3	21.1	12.4	113.9	48.5	19.5	10.7	108.3	51.3	18.6	9.8	102.7	54.2	17.6	8.8									46
7	136.1	41.1	23.3	15.0	127.1	44.9	21.8	13.2	117.8	49.2	20.2	11.5	112.1	52.0	19.2	10.4	111.0	53.6	19.0	10.2									45
8	140.5	41.8	24.1	15.8	131.3	45.7	22.5	14.0	121.7	50.0	20.9	12.2	115.9	52.8	19.9	11.1	115.0	54.3	19.7	10.9									45
9	145.1	42.4	24.9	16.8	135.6	46.4	23.2	14.9	125.8	50.7	21.6	13.0	119.8	53.5	20.5	11.8	119.0	55.0	20.4	11.7									44
10	149.7	43.2	25.7	17.7	139.9	47.1	24.0	15.7	129.9	51.5	22.3	13.7	123.7	54.4	21.2	12.6	123.2	55.8	21.1	12.5									44

Model: ACW10150SSLN																													
Ambient Temperature (°C)																													
CWT	30				35				40				43				46				50				52				MAT
	Q	P	WFR	Pd	Q	P	WFR	Pd	Q	P	WFR	Pd	Q	P	WFR	Pd	Q	P	WFR	Pd	Q	P	WFR	Pd	Q	P	WFR	Pd	
5	147.8	43.8	25.3	17.3	138.5	47.9	23.7	15.4	128.8	52.5	22.1	13.5	122.8	55.5	21.0	12.4	116.6	58.7	20.0	11.3									49
6	153.1	44.4	26.2	18.4	143.5	48.6	24.6	16.4	133.4	53.2	22.9	14.4	127.2	56.2	21.8	13.2	121.0	59.4	20.7	12.0									49
7	158.4	45.1	27.2	19.6	148.5	49.2	25.5	17.5	138.2	53.9	23.7	15.4	131.8	56.9	22.6	14.1	125.4	60.1	21.5	12.9									48
8	163.8	45.7	28.1	20.8	153.6	49.9	26.3	18.6	143.0	54.6	24.5	16.4	136.5	57.6	23.4	15.0	129.9	60.8	22.3	13.7									48
9	169.3	46.4	29.0	22.0	158.9	50.6	27.2	19.7	148.0	55.3	25.4	17.4	141.3	58.4	24.2	16.0	134.5	61.6	23.1	14.6									47
10	175.0	47.1	30.0	23.3	164.2	51.3	28.2	20.9	153.0	56.1	26.2	18.4	146.2	59.2	25.1	17.0	139.2	62.4	23.9	15.6									47

Model: ACW10180MELN																													
Ambient Temperature (°C)																													
CWT	30				35				40				43				46				50				52				MAT
	Q	P	WFR	Pd	Q	P	WFR	Pd	Q	P	WFR	Pd	Q	P	WFR	Pd	Q	P	WFR	Pd	Q	P	WFR	Pd	Q	P	WFR	Pd	
5	178.3	56.0	30.6	21.8	167.7	61.7	28.8	19.5	156.7	68.1	26.9	17.2	150.0	72.5	25.7	15.8	147.8	75.5	25.3	15.4									45
6	184.3	56.9	31.6	23.2	173.5	62.6	29.7	20.8	162.3	69.2	27.8	18.3	155.3	73.5	26.6	16.9	153.3	76.5	26.3	16.5									45
7	190.5	57.8	32.7	24.7	179.4	63.6	30.8	22.1	167.9	70																			

Low Noise, Medium and Standard Ambient Temperature, 1-Compressor Units

Model: ACW10210SSLN																													
Ambient Temperature (°C)																													
CWT	30				35				40				43				46				50				52				MAT
	Q	P	WFR	Pd	Q	P	WFR	Pd	Q	P	WFR	Pd	Q	P	WFR	Pd	Q	P	WFR	Pd	Q	P	WFR	Pd	Q	P	WFR	Pd	
5	207.0	61.5	35.5	28.8	195.4	67.5	33.5	25.9	183.3	74.4	31.4	23.0	175.8	79.0	30.1	21.3	168.1	84.1	28.8	19.6								48	
6	214.2	62.3	36.7	30.7	202.3	68.4	34.7	27.6	189.9	75.4	32.5	24.5	182.2	80.1	31.2	22.7	174.3	85.2	29.9	20.9								48	
7	221.6	63.2	38.0	32.6	209.4	69.4	35.9	29.4	196.7	76.5	33.7	26.2	188.8	81.2	32.4	24.3	180.7	86.3	31.0	22.4								47	
8	229.0	64.1	39.3	34.7	216.5	70.3	37.1	31.3	203.5	77.5	34.9	27.9	195.4	82.3	33.5	25.9	187.2	87.5	32.1	23.9								47	
9	236.7	65.0	40.6	36.8	223.8	71.3	38.4	33.2	210.5	78.6	36.1	29.7	202.2	83.4	34.7	27.6	193.8	88.7	33.2	25.5								46	
10	244.4	66.0	41.9	39.0	231.3	72.4	39.7	35.3	217.6	79.7	37.3	31.6	209.2	84.6	35.9	29.3	200.6	89.9	34.4	27.2								46	

Model: ACW10240MSLN																													
Ambient Temperature (°C)																													
CWT	30				35				40				43				46				50				52				MAT
	Q	P	WFR	Pd	Q	P	WFR	Pd	Q	P	WFR	Pd	Q	P	WFR	Pd	Q	P	WFR	Pd	Q	P	WFR	Pd	Q	P	WFR	Pd	
5	237.9	72.3	40.8	23.8	223.1	79.6	38.2	21.2	207.9	87.8	35.6	18.5	198.7	93.3	34.1	17.0	195.6	97.5	33.5	16.5								45	
6	245.8	73.4	42.1	25.3	230.6	80.7	39.5	22.5	215.0	89.1	36.9	19.7	205.4	94.7	35.2	18.1	202.5	98.7	34.7	17.6								45	
7	253.9	74.6	43.5	26.9	238.3	81.9	40.8	23.9	222.1	90.4	38.1	21.0	212.3	96.0	36.4	19.3	209.6	99.9	35.9	18.8								45	
8	262.0	75.7	44.9	28.5	245.9	83.2	42.2	25.3	229.3	91.7	39.3	22.3	219.2	97.4	37.6	20.5	216.7	101.2	37.2	20.0								44	
9	270.2	76.9	46.3	30.1	253.7	84.4	43.5	26.8	236.6	93.1	40.6	23.6	226.2	98.8	38.8	21.7	224.0	102.5	38.4	21.3								44	
10	278.6	78.1	47.8	31.8	261.6	85.7	44.8	28.4	244.0	94.5	41.8	25.0	233.3	100.3	40.0	23.0	231.4	103.8	39.7	22.6								43	

Model: ACW10270MSLN																													
Ambient Temperature (°C)																													
CWT	30				35				40				43				46				50				52				MAT
	Q	P	WFR	Pd	Q	P	WFR	Pd	Q	P	WFR	Pd	Q	P	WFR	Pd	Q	P	WFR	Pd	Q	P	WFR	Pd	Q	P	WFR	Pd	
5	269.9	81.8	46.3	13.4	253.5	90.1	43.5	11.9	236.6	99.5	40.6	10.5	226.2	105.8	38.8	9.6	224.2	109.0	38.4	9.5								45	
6	278.7	83.1	47.8	14.2	261.9	91.5	44.9	12.7	244.5	101.0	41.9	11.1	233.8	107.3	40.1	10.3	232.2	110.4	39.8	10.1								45	
7	287.7	84.5	49.3	15.1	270.4	92.9	46.4	13.4	252.6	102.6	43.3	11.8	241.6	109.0	41.4	10.9	240.3	111.9	41.2	10.8								44	
8	296.9	85.8	50.9	16.0	279.1	94.4	47.8	14.3	260.8	104.2	44.7	12.6	249.6	110.7	42.8	11.6	248.7	113.4	42.6	11.5								44	
9	306.1	87.2	52.5	16.9	287.9	95.9	49.4	15.1	269.1	105.8	46.1	13.3	257.6	112.4	44.2	12.3	257.1	114.9	44.1	12.2								43	
10	315.5	88.7	54.1	17.9	296.8	97.5	50.9	16.0	277.6	107.5	47.6	14.1	265.7	114.1	45.6	13.0	265.8	116.5	45.6	13.0								43	

Model: ACW10305MELN																													
Ambient Temperature (°C)																													
CWT	30				35				40				43				46				50				52				MAT
	Q	P	WFR	Pd	Q	P	WFR	Pd	Q	P	WFR	Pd	Q	P	WFR	Pd	Q	P	WFR	Pd	Q	P	WFR	Pd	Q	P	WFR	Pd	
5	302.4	93.2	51.8	16.5	284.1	102.6	48.7	14.7	265.2	113.4	45.5	13.0	253.6	120.5	43.5	11.9	250.0	125.6	42.9	11.6								45	
6	312.4	94.7	53.5	17.5	293.6	104.2	50.3	15.6	274.2	115.0	47.0	13.8	262.3	122.3	45.0	12.7	258.9	127.2	44.4	12.4								45	
7	322.5	96.1	55.3	18.6	303.2	105.7	52.0	16.6	283.3	116.7	48.6	14.6	271.1	124.1	46.5	13.5	268.0	128.8	45.9	13.2								45	
8	332.8	97.6	57.0	19.7	313.0	107.4	53.7	17.6	292.6	118.5	50.2	15.5	280.0	125.9	48.0	14.3	277.2	130.5	47.5	14.1								44	
9	343.2	99.2	58.8	20.9	322.9	109.0	55.4	18.6	302.0	120.3	51.8	16.5	289.1	127.8	49.6	15.2	286.7	132.2	49.1	15.0								44	
10	353.9	100.7	60.7	22.1	333.0	110.7	57.1	19.7	311.5	122.2	53.4	17.5	298.3	129.7	51.1	16.1	296.3	134.0	50.8	15.9								43	

- Q: Cooling Capacity in kW
- P: Total Power Absorbed in kW
- WFR: Water Flow Rate in m3/hr.
- Pd: Water Pressure Drop in kPa
- CWT: Chilled Water Temperature in °C (ΔT = 5°C)
- MAT: Maximum Ambient Temperature in °C
- NOTES:

- Data on grey background: unit switched to non-silenced operation
- Waterflow and pressure drop on heat exchangers calculated with 5°C of delta T
- Interpolation between rating is permissible but extrapolation is not.
- When the external air temperature is higher than the "MAT" the chiller doesn't stop but the "unloading" system capacity control is activated.

Low Noise, Medium and Standard Ambient Temperature, 2-Compressor Units

Model: ACW20200SHLN																																	
Ambient Temperature (°C)																																	
CWT	30				35				40				43				46				50				52				MAT				
	Q	P	WFR	Pd	Q	P	WFR	Pd	Q	P	WFR	Pd	Q	P	WFR	Pd	Q	P	WFR	Pd	Q	P	WFR	Pd	Q	P	WFR	Pd		Q	P	WFR	Pd
5	198.8	58.0	34.1	17.0	187.1	62.9	32.1	15.1	174.9	68.7	30.0	13.2	167.3	72.6	28.7	12.1	159.7	77.1	27.4	11.0													49
6	205.7	58.8	35.3	18.1	193.6	63.7	33.2	16.1	181.1	69.5	31.0	14.2	173.4	73.5	29.7	13.0	165.5	78.0	28.4	11.9													48
7	212.7	59.6	36.5	19.3	200.3	64.5	34.3	17.2	187.4	70.4	32.1	15.2	179.5	74.4	30.8	13.9	171.4	78.9	29.4	12.7													48
8	219.8	60.4	37.7	20.6	207.0	65.4	35.5	18.4	193.8	71.3	33.2	16.2	185.7	75.3	31.8	14.9	177.4	79.8	30.4	13.6													48
9	226.9	61.2	38.9	21.8	213.9	66.2	36.7	19.5	200.3	72.2	34.3	17.2	192.0	76.2	32.9	15.9	183.5	80.7	31.5	14.5													47
10	234.3	62.1	40.2	23.2	220.8	67.1	37.9	20.8	207.0	73.1	35.5	18.3	198.4	77.2	34.0	16.9	189.7	81.7	32.5	15.5													47

Model: ACW20225SSLN																																	
Ambient Temperature (°C)																																	
CWT	30				35				40				43				46				50				52				MAT				
	Q	P	WFR	Pd	Q	P	WFR	Pd	Q	P	WFR	Pd	Q	P	WFR	Pd	Q	P	WFR	Pd	Q	P	WFR	Pd	Q	P	WFR	Pd		Q	P	WFR	Pd
5	222.1	65.5	38.1	21.0	208.3	71.3	35.7	18.6	194.1	77.8	33.3	16.2	185.4	82.0	31.8	14.8	176.6	86.6	30.3	13.5													47
6	229.5	66.3	39.3	22.3	215.4	72.2	36.9	19.8	200.8	78.7	34.4	17.3	191.9	83.0	32.9	15.9	182.9	87.6	31.4	14.5													47
7	237.1	67.2	40.6	23.7	222.6	73.1	38.2	21.1	207.7	79.7	35.6	18.5	198.6	84.1	34.0	16.9	189.4	88.7	32.5	15.5													46
8	244.7	68.1	42.0	25.1	229.9	74.1	39.4	22.4	214.6	80.8	36.8	19.7	205.2	85.1	35.2	18.1	195.8	89.8	33.6	16.5													46
9	252.5	69.1	43.3	26.6	237.3	75.1	40.7	23.7	221.6	81.8	38.0	20.9	212.0	86.2	36.4	19.2	209.0	90.0	35.8	18.7													45
10	260.4	70.0	44.6	28.1	244.8	76.1	42.0	25.1	228.7	82.9	39.2	22.2	219.0	87.3	37.5	20.4	216.2	91.0	37.1	19.9													45

Model: ACW20245MELN																																	
Ambient Temperature (°C)																																	
CWT	30				35				40				43				46				50				52				MAT				
	Q	P	WFR	Pd	Q	P	WFR	Pd	Q	P	WFR	Pd	Q	P	WFR	Pd	Q	P	WFR	Pd	Q	P	WFR	Pd	Q	P	WFR	Pd		Q	P	WFR	Pd
5	244.5	81.4	41.9	25.1	227.9	89.2	39.1	22.0	210.6	98.0	36.1	19.0	200.1	103.6	34.3	17.2	197.1	107.6	33.8	16.7													45
6	252.7	82.7	43.3	26.6	235.6	90.6	40.4	23.4	217.9	99.4	37.4	20.2	207.0	105.1	35.5	18.4	204.3	109.0	35.0	17.9													45
7	261.1	84.0	44.8	28.3	243.5	92.0	41.7	24.9	225.3	100.9	38.6	21.5	214.1	106.6	36.7	19.6	211.6	110.3	36.3	19.1		</											

Low Noise, Medium and Standard Ambient Temperature, 2-Compressor Units

Model: ACW20845MHLN																													
Ambient Temperature (°C)																													
CWT	30				35				40				43				46				50				52				MAT
	Q	P	WFR	Pd	Q	P	WFR	Pd	Q	P	WFR	Pd	Q	P	WFR	Pd	Q	P	WFR	Pd	Q	P	WFR	Pd	Q	P	WFR	Pd	
5	843.5	244.0	144.6	59.4	793.9	265.0	136.1	53.1	741.8	288.7	127.2	46.9	709.7	304.4	121.7	43.2	698.7	318.1	119.8	42.0									45
6	871.5	247.3	149.4	63.0	820.4	268.5	140.6	56.4	766.8	292.4	131.4	49.8	733.7	308.3	125.8	45.9	723.2	321.6	124.0	44.7									45
7	899.9	250.7	154.3	66.9	847.3	272.2	145.3	59.8	792.1	296.3	135.8	52.9	758.1	312.3	130.0	48.8	748.3	325.4	128.3	47.6									45
8	928.7	254.2	159.2	71.0	874.6	275.9	149.9	63.5	817.8	300.3	140.2	56.1	782.8	316.5	134.2	51.7	773.7	329.2	132.6	50.6									44
9	957.9	257.9	164.2	75.2	902.3	279.8	154.7	67.2	843.9	304.5	144.7	59.4	807.8	320.8	138.5	54.8	799.6	333.1	137.1	53.8									44
10	987.5	261.6	169.3	79.7	930.4	283.8	159.5	71.2	870.4	308.7	149.2	62.9	833.3	325.2	142.8	58.0	826.0	337.2	141.6	57.1									43

Model: ACW21010SHLN																													
Ambient Temperature (°C)																													
CWT	30				35				40				43				46				50				52				MAT
	Q	P	WFR	Pd	Q	P	WFR	Pd	Q	P	WFR	Pd	Q	P	WFR	Pd	Q	P	WFR	Pd	Q	P	WFR	Pd	Q	P	WFR	Pd	
5	999.8	277.7	171.4	54.1	946.2	303.6	162.2	48.9	890.3	331.7	152.6	43.8	855.8	349.5	146.7	40.8	820.5	368.0	140.7	37.8									47
6	1032.3	281.4	177.0	57.4	977.5	307.6	167.6	51.9	920.3	336.0	157.8	46.5	885.0	354.0	151.7	43.3	848.9	372.7	145.5	40.2									47
7	1065.4	285.2	182.6	60.8	1009.3	311.7	173.0	55.1	950.8	340.4	163.0	49.4	914.7	358.6	156.8	46.0	877.8	377.4	150.5	42.7									46
8	1100.2	289.2	188.6	64.5	1042.7	316.0	178.8	58.4	982.9	345.0	168.5	52.5	945.9	363.3	162.1	48.9	908.1	382.4	155.7	45.4									46
9	1135.5	293.3	194.7	68.4	1076.8	320.4	184.6	62.0	1015.5	349.7	174.1	55.7	977.6	368.2	167.6	51.9	970.4	380.4	166.4	51.2									45
10	1171.5	297.5	200.8	72.4	1111.4	324.9	190.5	65.7	1048.7	354.5	179.8	59.1	1010.0	373.2	173.1	55.1	1004.1	385.0	172.1	54.5									45

Model: ACW21055MHLN																													
Ambient Temperature (°C)																													
CWT	30				35				40				43				46				50				52				MAT
	Q	P	WFR	Pd	Q	P	WFR	Pd	Q	P	WFR	Pd	Q	P	WFR	Pd	Q	P	WFR	Pd	Q	P	WFR	Pd	Q	P	WFR	Pd	
5	1047.8	299.7	179.6	59.0	991.3	327.8	169.9	53.3	932.3	358.2	159.8	47.6	895.8	377.5	153.6	44.3	886.7	390.6	152.0	43.5									45
6	1081.3	303.8	185.4	62.5	1023.5	332.3	175.5	56.5	963.1	363.0	165.1	50.5	925.8	382.5	158.7	47.0	917.7	395.2	157.3	46.3									45
7	1115.3	308.0	191.2	66.1	1056.2	336.8	181.1	59.8	994.5	367.9	170.5	53.6	956.4	387.5	163.9	49.9	949.4	399.8	162.8	49.2									44
8	1150.9	312.4	197.3	70.1	1090.4	341.6	186.9	63.4	1027.4	373.0	176.1	56.9	988.4	392.9	169.4	53.0	982.8	404.6	168.5	52.4									43
9	1187.0	317.0	203.5	74.3	1125.3	346.5	192.9	67.2	1060.8	378.3	181.9	60.3	1020.9	398.3	175.0	56.2	1016.8	409.5	174.3	55.8									43
10	1223.7	321.6	209.8	78.6	1160.7	351.5	199.0	71.2	1094.8	383.6	187.7	63.9	1092.6	394.3	187.3	63.7	1051.5	414.5	180.3	59.3									42

- Q; Cooling Capacity in kW
- P; Total Power Absorbed in kW
- WFR; Water Flow Rate in m3/hr.
- Pd; Water Pressure Drop in kPa
- CWT; Chilled Water Temperature in °C (ΔT = 5°C)
- MAT; Maximum Ambient Temperature in °C

- NOTES:
 - Data on grey background: unit switched to non-silenced operation
 - Waterflow and pressure drop on heat exchangers calculated with 5°C of delta T
 - Interpolation between rating is permissible but extrapolation is not.
 - When the external air temperature is higher than the "MAT" the chiller doesn't stop but the "unloading" system capacity control is activated.

Low Noise, Medium and Standard Ambient Temperature, 3-Compressor Units

Model: ACW31465MSLN																																	
Ambient Temperature (°C)																																	
CWT	30				35				40				43				46				50				52				MAT				
	Q	P	WFR	Pd	Q	P	WFR	Pd	Q	P	WFR	Pd	Q	P	WFR	Pd	Q	P	WFR	Pd	Q	P	WFR	Pd	Q	P	WFR	Pd		Q	P	WFR	Pd
5	1454.1	428.4	249.3	63.0	1375.2	468.9	235.7	56.8	1292.6	512.5	221.6	50.7	1241.4	540.1	212.8	47.1	1232.5	556.1	211.3	46.5													45
6	1500.1	434.5	257.2	66.7	1419.6	475.6	243.4	60.3	1335.2	519.7	228.9	53.8	1282.9	547.6	219.9	50.0	1275.8	562.9	218.7	49.5													44
7	1546.7	440.8	265.2	70.6	1464.6	482.4	251.1	63.8	1378.5	527.0	236.3	57.1	1325.1	555.2	227.2	53.1	1319.9	569.7	226.3	52.7												44	
8	1593.8	447.1	273.2	74.6	1510.2	489.3	258.9	67.6	1422.3	534.4	243.8	60.5	1367.8	562.9	234.5	56.3	1364.7	576.7	234.0	56.0												43	
9	1641.2	453.6	281.4	78.8	1556.3	496.3	266.8	71.4	1466.8	542.0	251.4	64.0	1411.2	570.8	241.9	59.6	1410.4	583.8	241.8	59.6												43	
10	1689.0	460.1	289.5	83.1	1602.8	503.4	274.8	75.4	1511.8	549.7	259.2	67.7	1513.9	562.0	259.5	67.9	1456.8	591.1	249.7	63.2												42	

Model: ACW31500SHLN																																
Ambient Temperature (°C)																																
CWT	30				35				40				43				46				50				52				MAT			
	Q	P	WFR	Pd	Q	P	WFR	Pd	Q	P	WFR	Pd	Q	P	WFR	Pd	Q	P	WFR	Pd	Q	P	WFR	Pd	Q	P	WFR	Pd		Q	P	WFR
5	1484.9	414.8	254.6	65.5	1407.6	453.9	241.3	59.3	1326.2	496.2	227.3	53.2	1275.6	523.0	218.7	49.5	1223.8	550.9	209.8	45.9												47
6	1532.9	420.3	262.8	69.4	1454.1	459.9	249.3	63.0	1371.0	502.6	235.0	56.5	1319.4	529.7	226.2	52.7	1266.4	557.9	217.1	48.8												47
7	1581.6	425.9	271.1	73.6	1501.3	465.9	257.4	66.8	1416.6	509.2	242.9	60.0	1363.9	536.6	233.8	56.0	1309.9	565.0	224.5	52.0												46
8	1630.7	431.6	279.6	77.8	1549.2	472.1	265.6	70.8	1462.9	515.9	250.8	63.7	1409.1	543.5	241.6	59.5	1354.0	572.2	232.1	55.2											46	
9	1680.2	437.3	288.0	82.3	1597.6	478.4	273.9	74.9	1509.9	522.6	258.8	67.5	1455.1	550.6	249.4	63.1	1444.2	569.1	247.6	62.2											45	
10	1730.0	443.0	296.6	86.8	1646.6	484.7	282.3	79.2	1557.5	529.5	267.0	71.5	1501.8	557.8	257.4	66.9	1492.7	575.6	255.9	66.1											45	

- Q; Cooling Capacity in kW
- P; Total Power Absorbed in kW
- WFR; Water Flow Rate in m3/hr.
- Pd; Water Pressure Drop in kPa
- CWT; Chilled Water Temperature in °C (ΔT = 5°C)
- MAT; Maximum Ambient Temperature in °C

- NOTES:
 - Data on grey background: unit switched to non-silenced operation
 - Waterflow and pressure drop on heat exchangers calculated with 5°C of delta T
 - Interpolation between rating is permissible but extrapolation is not.
 - When the external air temperature is higher than the "MAT" the chiller doesn't stop but the "unloading" system capacity control is activated.

Low Noise, Medium and Standard Ambient Temperature, 1-Compressor Units

Model: ACW10100HHLN																													
Ambient Temperature (°C)																													
CWT	30				35				40				43				46				50				52				MAT
	Q	P	WFR	Pd	Q	P	WFR	Pd	Q	P	WFR	Pd	Q	P	WFR	Pd	Q	P	WFR	Pd	Q	P	WFR	Pd	Q	P	WFR	Pd	
5	99.2	28.2	17.0	3.7	93.5	30.5	16.0	3.3	87.6	33.3	15.0	2.9	84.0	35.2	14.4	2.6	80.3	37.3	13.8	2.4	77.0	40.2	13.2	2.2					49
6	102.6	28.5	17.6	3.9	96.8	30.9	16.6	3.5	90.7	33.7	15.6	3.1	87.0	35.6	14.9	2.8	83.2	37.7	14.3	2.6	79.9	40.6	13.7	2.4					49
7	106.0	28.9	18.2	4.2	100.1	31.3	17.2	3.7	93.9	34.1	16.1	3.3	90.0	36.0	15.4	3.0	86.1	38.1	14.8	2.8	82.9	41.0	14.2	2.5					49
8	109.7	29.3	18.8	4.5	103.5	31.7	17.7	4.0	97.2	34.5	16.7	3.5	93.2	36.4	16.0	3.2	89.2	38.5	15.3	3.0	86.0	41.3	14.7	2.7					49
9	113.4	29.7	19.4	4.7	107.1	32.1	18.4	4.3	100.5	34.9	17.2	3.8	96.5	36.8	16.5	3.5	92.4	39.0	15.8	3.2	89.2	41.8	15.3	3.0					49
10	117.2	30.1	20.1	5.1	110.7	32.5	19.0	4.5	104.0	35.3	17.8	4.0	99.8	37.3	17.1	3.7	95.6	39.4	16.4	3.4	92.4	42.2	15.8	3.2					48

Model: ACW10110SHLN																													
Ambient Temperature (°C)																													
CWT	30				35				40				43				46				50				52				MAT
	Q	P	WFR	Pd	Q	P	WFR	Pd	Q	P	WFR	Pd	Q	P	WFR	Pd	Q	P	WFR	Pd	Q	P	WFR	Pd	Q	P	WFR	Pd	
5	111.0	31.7	19.0	4.6	104.3	34.5	17.9	4.0	97.5	37.6	16.7	3.5	93.2	39.7	16.0	3.2	89.0	41.9	15.3	2.9	85.7	44.7	14.7	2.7					49
6	114.7	32.1	19.7	4.9	107.8	34.9	18.5	4.3	100.8	38.1	17.3	3.8	96.5	40.1	16.5	3.5	92.1	42.4	15.8	3.2	88.8	45.1	15.2	2.9					48
7	118.4	32.5	20.3	5.2	111.4	35.3	19.1	4.6	104.2	38.5	17.9	4.0	99.8	40.6	17.1	3.7	95.3	42.9	16.3	3.4	92.1	45.5	15.8	3.2					48
8	122.4	32.9	21.0	5.5	115.2	35.8	19.7	4.9	107.8	39.0	18.5	4.3	103.3	41.1	17.7	4.0	98.7	43.4	16.9	3.6	95.5	46.0	16.4	3.4					48
9	126.4	33.4	21.7	5.8	119.0	36.3	20.4	5.2	111.5	39.5	19.1	4.6	106.8	41.6	18.3	4.2	102.1	43.9	17.5	3.9	99.0	46.5	17.0	3.6					47
10	130.5	33.8	22.4	6.2	123.0	36.7	21.1	5.5	115.2	40.0	19.7	4.9	110.4	42.2	18.9	4.5	105.6	44.4	18.1	4.1									47

Model: ACW10135HHLN																													
Ambient Temperature (°C)																													
CWT	30				35				40				43				46				50				52				MAT
	Q	P	WFR	Pd	Q	P	WFR	Pd	Q	P	WFR	Pd	Q	P	WFR	Pd	Q	P	WFR	Pd	Q	P	WFR	Pd	Q	P	WFR	Pd	
5	135.1	37.2	23.2	14.8	126.9	40.5	21.7	13.2	118.2	44.3	20.3	11.5	112.9	46.8	19.4	10.6	107.5	49.4	18.4	9.6	100.1	53.2	17.2	8.4	98.7	55.5	16.9	8.1	51
6	140.0	37.6	24.0	15.7	131.5	41.0	22.5	14.1	122.7	44.8	21.0	12.4	117.2	47.3	20.1	11.4	111.6	50.0	19.1	10.3	104.0	53.8	17.8	9.0	102.7	56.1	17.6	8.8	51
7	145.0	38.1	24.9	16.8	136.3	41.6	23.4	15.0	127.2	45.4	21.8	13.2	121.6	47.9	20.8	12.2	115.8	50.5	19.9	11.1	108.0	54.4	18.5	9.7	106.7	56.6	18.3	9.5	51
8	150.2	38.7	25.7	17.8	141.2	42.1	24.2	16.0	131.8	45.9	22.6	14.1	126.1	48.5	21.6	13.0	120.1	51.1	20.6	11.9	112.1	55.0	19.2	10.4	110.9	57.2	19.0	10.2	51
9	155.4	39.2	26.6	18.9	146.2	42.6	25.1	17.0	136.6	46.5	23.4	15.1	130.6	49.0	22.4	13.9	124.6	51.7	21.4	12.7	116.3	55.6	19.9	11.2	115.2	57.7	19.7	11.0	50
10	160.8	39.7	27.6	20.1	151.3	43.2	25.9	18.1	141.4	47.1	24.2	16.0	135.3	49.7	23.2	14.8	129.1	52.4	22.1	13.6	120.6	56.2	20.7	12.0	119.6	58.3	20.5	11.8	50

Model: ACW10150HHLN																													
Ambient Temperature (°C)																													
CWT	30				35				40				43				46				50				52				MAT
	Q	P	WFR	Pd	Q	P	WFR	Pd	Q	P	WFR	Pd	Q	P	WFR	Pd	Q	P	WFR	Pd	Q	P	WFR	Pd	Q	P	WFR	Pd	
5	150.4	42.7	25.8	17.9	141.1	46.7	24.2	16.0	131.4	51.1	22.5	14.0	125.5	54.0	21.5	12.9	119.4	57.1	20.5	11.8	114.2	61.4	19.6	10.8					49
6	155.7	43.3	26.7	19.0	146.2	47.3	25.1	17.0	136.3	51.8	23.4	15.0	130.1	54.7	22.3	13.8	123.9	57.8	21.2	12.6	118.7	62.0	20.3	11.6					49
7	161.2	43.9	27.6	20.2	151.4	47.9	26.0	18.1	141.2	52.4	24.2	16.0	134.9	55.4	23.1	14.7	128.4	58.5	22.0	13.5	123.3	62.7	21.1	12.5					49
8	166.8	44.5	28.6	21.4	156.7	48.6	26.9	19.2	146.2	53.1	25.1	17.0	139.7	56.1	24.0	15.7	133.1	59.2	22.8	14.4	127.9	63.3	21.9	13.4					49
9	172.5	45.2	29.6	22.7	162.1	49.3	27.8	20.4	151.3	53.8	25.9	18.1	144.7	56.8	24.8	16.7	137.9	60.0	23.6	15.3	132.7	64.0	22.8	14.3					49
10	178.3	45.8	30.6	24.1	167.7	50.0	28.7	21.6	156.6	54.6	26.8	19.2	149.7	57.6	25.7	17.7	142.7	60.7	24.5	16.3	137.6	64.7	23.6	15.3					48

Model: ACW10190SHLN																													
Ambient Temperature (°C)																													
CWT	30				35				40				43				46				50				52				MAT
	Q	P	WFR	Pd	Q	P	WFR	Pd	Q	P	WFR	Pd	Q	P	WFR	Pd	Q	P	WFR	Pd	Q	P	WFR	Pd	Q	P	WFR	Pd	
5	185.6	53.0	31.8	23.5	175.3	58.0	30.1	21.2	164.6	63.8	28.2	18.8	158.0	67.7	27.1	17.4	151.2	71.9	25.9	16.1	145.1	78.0	24.9	14.9					49
6	192.1	53.7	32.9	25.1	181.6	58.8	31.1	22.6	170.7	64.6	29.3	20.1	163.9	68.5	28.1	18.7	157.0	72.8	26.9	17.2	150.8	78.8	25.9	16.0					49
7	198.9	54.4	34.1	26.7	188.1	59.5	32.3	24.1	176.9	65.4	30.3	21.5	170.0	69.4	29.1	20.0	162.9	73.7	27.9	18.4	156.7	79.7	26.9	17.2					49
8	205.8	55.1	35.3	28.5	194.7	60.3	33.4	25.7	183.2	66.3	31.4	23.0	176.1	70.3	30.2	21.3	168.9	74.6	28.9	19.7	162.7	80.6	27.9	18.4					49
9	212.8	55.9	36.5	30.3	201.5	61.1	34.5	27.4	189.7	67.1	32.5	24.5	182.4	71.2	31.3	22.8	175.0	75.5	30.0	21.1	168.9	81.4	28.9	19.7					48
10	219.9	56.6	37.7	32.2	208.3	61.9	35.7	29.1	196.3	68.0	33.6	26.1	188.8	72.1	32.4	24.3	181.2	76.5	31.1	22.5	175.1	82.3	30.0	21.1					48

- Q; Cooling Capacity in kW
- P; Total Power Absorbed in kW
- WFR; Water Flow Rate in m3/hr.
- Pd; Water Pressure Drop in kPa
- CWT; Chilled Water Temperature in °C (ΔT = 5°C)
- MAT; Maximum Ambient Temperature in °C
- NOTES:
 - Data on grey background: unit switched to non-silenced operation
 - Waterflow and pressure drop on heat exchangers calculated with 5°C of delta T
 - Interpolation between rating is permissible but extrapolation is not.
 - When the external air temperature is higher than the "MAT" the chiller doesn't stop but the "unloading" system capacity control is activated.

Low Noise, Medium and Standard Ambient Temperature, 1-Compressor Units

Model: ACW10215SHLN																													
Ambient Temperature (°C)																													
CWT	30				35				40				43				46				50				52				MAT
	Q	P	WFR	Pd	Q	P	WFR	Pd	Q	P	WFR	Pd	Q	P	WFR	Pd	Q	P	WFR	Pd	Q	P	WFR	Pd	Q	P	WFR	Pd	
5	210.3	59.8	36.0	29.6	198.8	65.6	34.1	26.7	186.8	72.3	32.0	23.8	179.4	76.7	30.7	22.1	171.8	81.5	29.4	20.4	165.6	87.5	28.4	19.0					49
6	217.7	60.6	37.3	31.6	205.9	66.5	35.3	28.5	193.6	73.2	33.2	25.4	186.0	77.7	31.9	23.6	178.2	82.6	30.5	21.8	172.0	88.4	29.5	20.4					49
7	225.2	61.5	38.6	33.6	213.2	67.4	36.5	30.4	200.6	74.2	34.4	27.2	192.8	78.7	33.0	25.2	184.8	83.7	31.7	23.3	178.7	89.4	30.6	21.9					49
8	232.9	62.3	39.9	35.7	220.5	68.3	37.8	32.3	207.6	75.2	35.6	28.9	199.6	79.8	34.2	26.9	191.5	84.7	32.8	24.9	185.4	90.4	31.8	23.5					48
9	240.7	63.2	41.3	37.9	228.0	69.3	39.1	34.4	214.8	76.2	36.8	30.8	206.7	80.8	35.4	28.7	198.3	85.9	34.0	26.6	192.4	91.5	33.0	25.1					48
10	248.7	64.1	42.6	40.3	235.7	70.2	40.4	36.5	222.2	77.3	38.1	32.8	213.8	81.9	36.7	30.6	205.3	87.0	35.2	28.3	199.4	92.5	34.2	26.9					47

Model: ACW10250SHLN																													
Ambient Temperature (°C)																													
CWT	30				35				40				43				46				50				52				MAT
	Q	P	WFR	Pd	Q	P	WFR	Pd	Q	P	WFR	Pd	Q	P	WFR	Pd	Q	P	WFR	Pd	Q	P	WFR	Pd	Q	P	WFR	Pd	
5	246.1	69.2	42.2	25.4	231.7	75.8	39.7</																						

Low Noise, Standard Ambient Temperature, 3-Compressor Units

Model: ACW31210SELN																													
Ambient Temperature (°C)																													
CWT	30				35				40				43				46				50				52				MAT
	Q	P	WFR	Pd	Q	P	WFR	Pd	Q	P	WFR	Pd	Q	P	WFR	Pd	Q	P	WFR	Pd	Q	P	WFR	Pd	Q	P	WFR	Pd	
5	1208.4	383.8	207.2	73.1	1135.9	417.4	194.7	64.9	1061.0	454.6	181.9	57.0	1015.2	478.9	174.0	52.4	969.0	504.9	166.1	47.9	944.3	530.1	161.9	45.6					49
6	1246.5	389.4	213.7	77.5	1172.3	423.4	201.0	69.0	1095.6	461.0	187.8	60.6	1048.8	485.6	179.8	55.7	1001.5	511.9	171.7	51.0	977.7	536.5	167.6	48.7					48
7	1285.1	395.1	220.3	82.1	1209.3	429.5	207.3	73.2	1130.8	467.6	193.9	64.4	1082.8	492.4	185.6	59.3	1034.4	519.0	177.3	54.3	1011.8	543.1	173.5	52.0					47
8	1323.5	400.8	226.9	86.8	1246.1	435.6	213.6	77.5	1165.9	474.2	199.9	68.3	1116.9	499.3	191.5	62.9	1067.4	526.1	183.0	57.6	1046.0	549.7	179.3	55.5					47
9	1362.3	406.6	233.5	91.7	1283.4	441.9	220.0	81.9	1201.5	480.9	206.0	72.3	1151.4	506.3	197.4	66.6	1100.8	533.4	188.7	61.2									46
10	1401.7	412.5	240.3	96.7	1321.1	448.3	226.5	86.5	1237.6	487.7	212.2	76.5	1186.4	513.4	203.4	70.6	1134.7	540.8	194.5	64.8									46

Model: ACW31395SELN																													
Ambient Temperature (°C)																													
CWT	30				35				40				43				46				50				52				MAT
	Q	P	WFR	Pd	Q	P	WFR	Pd	Q	P	WFR	Pd	Q	P	WFR	Pd	Q	P	WFR	Pd	Q	P	WFR	Pd	Q	P	WFR	Pd	
5	1393.1	434.7	238.8	58.2	1313.4	475.7	225.1	52.2	1230.1	519.6	210.9	46.3	1178.5	547.1	202.0	42.8	1125.9	575.6	193.0	39.3	1108.3	595.9	190.0	38.2					48
6	1436.0	441.5	246.2	61.6	1354.4	483.0	232.2	55.3	1269.1	527.3	217.6	49.0	1216.4	555.2	208.5	45.4	1162.6	583.9	199.3	41.7	1146.9	603.5	196.6	40.7					47
7	1479.3	448.4	253.6	65.0	1395.9	490.4	239.3	58.4	1308.7	535.2	224.3	51.9	1254.7	563.4	215.1	48.0	1199.7	592.4	205.7	44.2	1186.1	611.2	203.3	43.3					46
8	1523.0	455.4	261.1	68.6	1437.8	497.9	246.5	61.7	1348.6	543.3	231.2	54.8	1293.5	571.7	221.7	50.8	1237.3	601.0	212.1	46.8									46
9	1567.1	462.5	268.6	72.3	1480.1	505.6	253.7	65.1	1389.0	551.5	238.1	57.9	1332.7	580.2	228.5	53.7	1344.1	587.7	230.4	54.5									45
10	1611.5	469.8	276.3	76.2	1522.8	513.4	261.1	68.6	1429.9	559.8	245.1	61.1	1372.4	588.9	235.3	56.6	1387.0	595.5	237.8	57.7									45

- Q; Cooling Capacity in kW
- P; Total Power Absorbed in kW
- WFR; Water Flow Rate in m3/hr.
- Pd; Water Pressure Drop in kPa
- CWT; Chilled Water Temperature in °C (ΔT = 5°C)
- MAT; Maximum Ambient Temperature in °C
- NOTES:

- I. Data on grey background: unit switched to non-silenced operation
- II. Waterflow and pressure drop on heat exchangers calculated with 5°C of delta T
- III. Interpolation between rating is permissible but extrapolation is not.
- IV. When the external air temperature is higher than the "MAT" the chiller doesn't stop but the "unloading" system capacity control is activated.

Water Side Evaporator Pressure Drop Curves

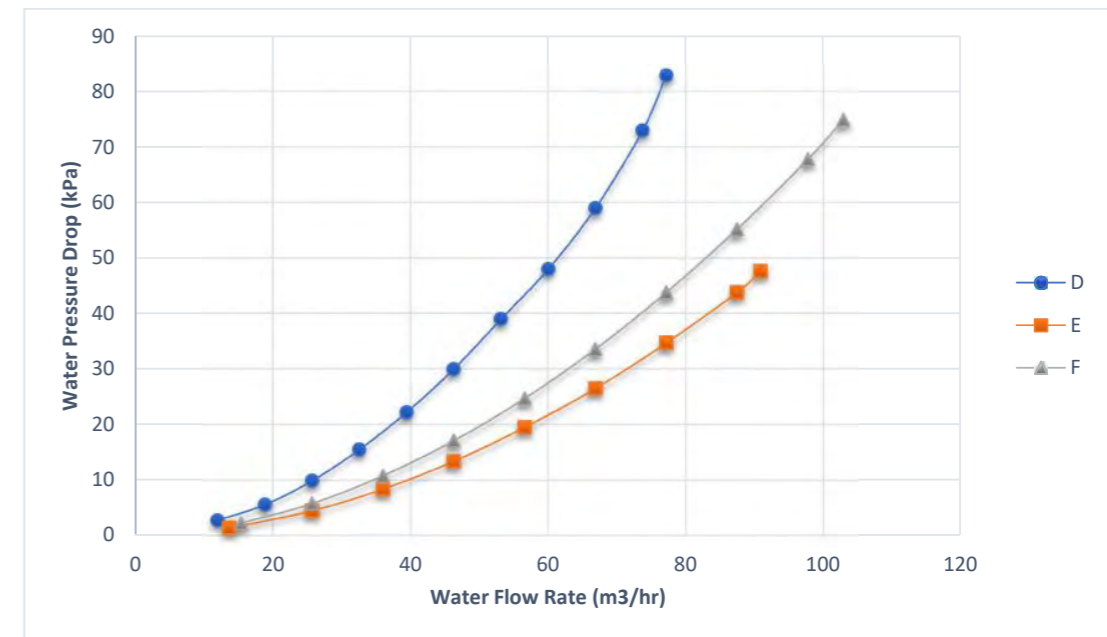
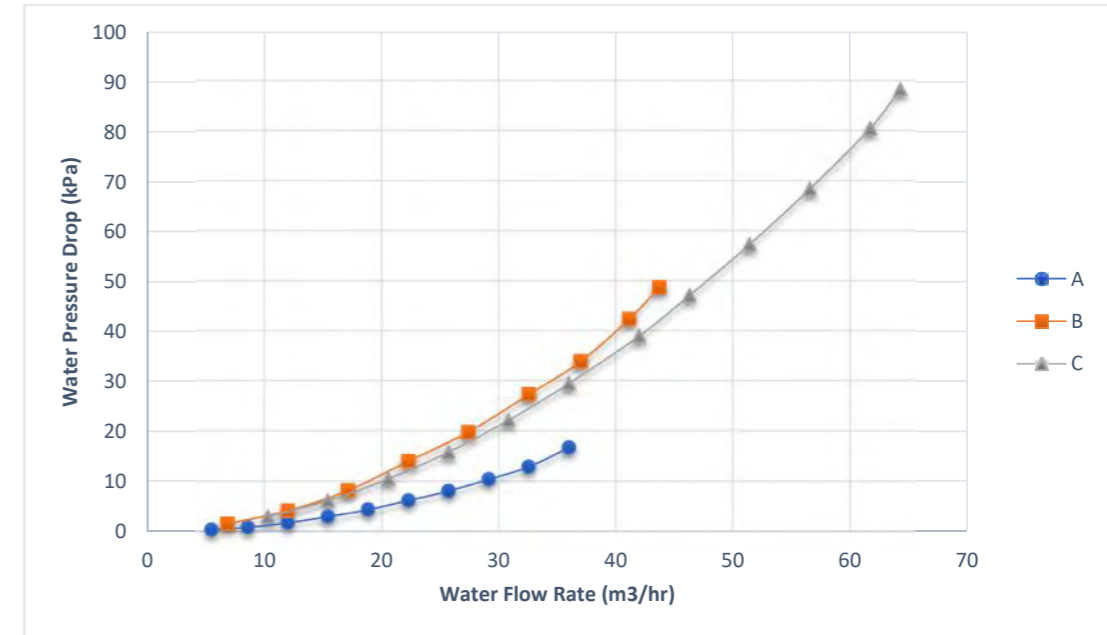

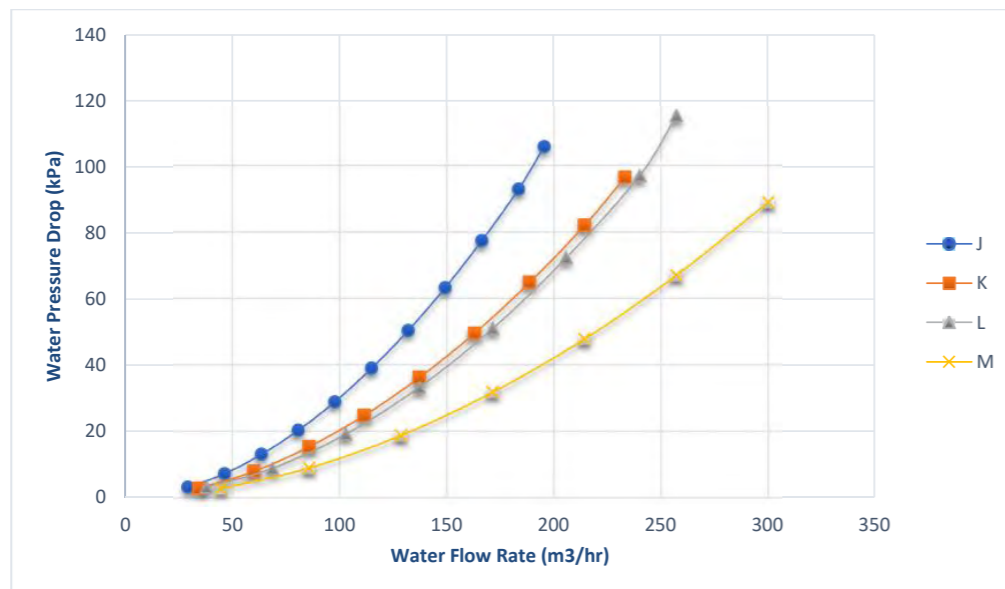
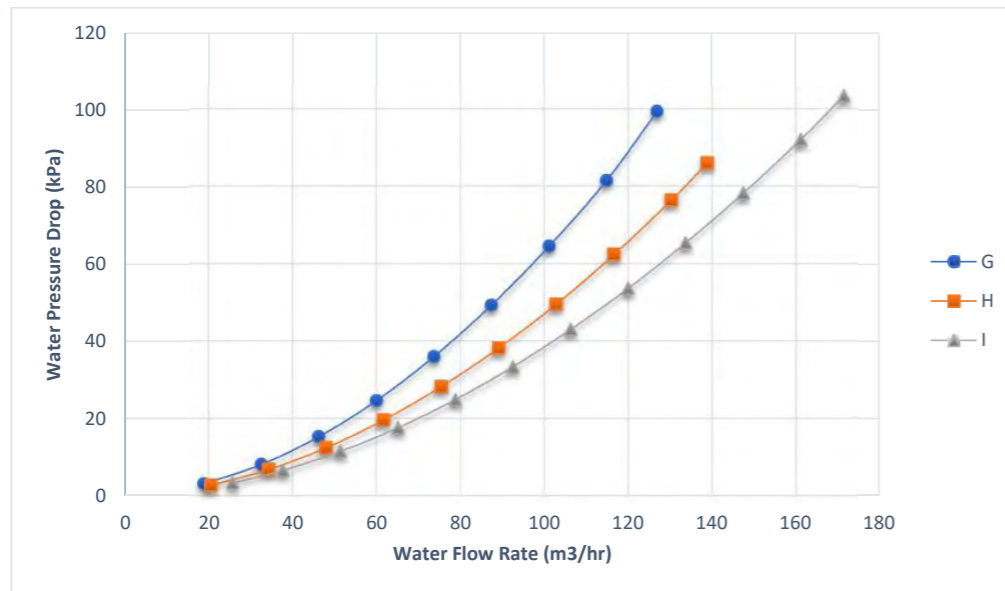

Curve	Model
A	ACW10100SSSN, ACW10100HHSN, ACW10110SSSN, ACW10115HHSN, ACW10100SSLN, ACW10100HHLN, ACW10110SSLN, ACW10110SHLN
B	ACW10130SSSN, ACW10135HHSN, ACW10150SSSN, ACW10155HHSN, ACW10125SELN, ACW10135HHLN, ACW10150SSLN, ACW10150HHLN
C	ACW10185SSSN, ACW10190HHSN, ACW10215SSSN, ACW10215HHSN, ACW10180MELN, ACW10190SHLN, ACW10210SSLN, ACW10215SHLN
D	ACW10245SSSN, ACW10255HHSN, ACW20205SHSN, ACW20210HHSN, ACW20230SHSN, ACW20235HHSN, ACW20255HHSN, ACW20250SESN, ACW20270HHSN, ACW10240MSLN, ACW10250SHLN, ACW20200SHLN, ACW20205HHLN, ACW20225SSLN, ACW20225SHLN, ACW20250HHLN, ACW20245MELN, ACW20260HHLN,
E	ACW10280SSSN, ACW10290HHSN, ACW10310SSSN, ACW10325HPSN, ACW20300HHSN, ACW20295SESN, ACW20315HHSN, ACW20335SSSN, ACW20350HHSN, ACW10270MSLN, ACW10285SHLN, ACW10305MELN, ACW10320SHLN, ACW20295SHLN, ACW20285MELN, ACW20310SHLN, ACW20330MSLN, ACW20340SHLN
F	ACW20375SHSN, ACW20385HHSN, ACW20400SSSN, ACW20410HHSN, ACW20425SSSN, ACW20435HHSN, ACW20365SSLN, ACW20375SHLN, ACW20390MSLN, ACW20405SHLN, ACW20420SSLN, ACW20425SHLN
G	ACW20480SHSN, ACW20485HPSN, ACW20500SSSN, ACW20515HHSN, ACW20470SHLN, ACW20480SPLN, ACW20485MSLN, ACW20505SHLN
H	ACW20565SHSN, ACW20575HHSN, ACW20620SSSN, ACW20645HHSN, ACW20550SSLN, ACW20565SHLN, ACW20600MELN, ACW20635SHLN
I	ACW20710SHSN, ACW20720HPSN, ACW20760SHSN, ACW20770HPSN, ACW20695SHLN, ACW20705SHLN, ACW20735SHLN, ACW20755SHLN
J	ACW20830SPSN, ACW20845HPSN, ACW20870SHSN, ACW20905HPSN, ACW20810SHLN, ACW20830SPLN, ACW20845MHLN, ACW20885SPLN
K	ACW21035SPSN, ACW21050HPSN, ACW21085SHSN, ACW21115HPSN, ACW21010SHLN, ACW21030SPLN, ACW21055MHLN, ACW21095SPLN
L	ACW31250HSSN, ACW31210SELN
M	ACW31510SHSN, ACW31540SPSN, ACW31455HSSN, ACW31465MSLN, ACW31500SHLN, ACW31395SELN

Operating Limits

Ambient Limitations

Arvand air-cooled chillers are designed for year-round operation over a range of ambient temperatures. Medium ambient, Standard ambient and High ambient units could be operating in condition inside envelope charts A, B and C in respect. With the low ambient options, these units will operate in lower ambient temperature. Our customers can always order a unit out of envelope condition, for this, contact to our specialist in Arvand company.

Water Flow Limits

The minimum and maximum water flow rates are given in the General Data tables. Evaporator flow rates below the tabulated values will result in laminar flow causing freeze up problems, scaling, stratification and poor control. Flow rates exceeding those listed may result in excessive tube erosion.

Note: Flow rates in General Data tables are for water only. They do not include glycol.

Leaving Water Temperature Limits

Arvand air-cooled ACW chillers have the standard leaving solution temperature range 5 to 15°C. Since water supply temperature setpoint less than 4.4°C, result in suction temperatures at or below the freezing point of water, a glycol solution is required for all low temperature machines.

Chart A

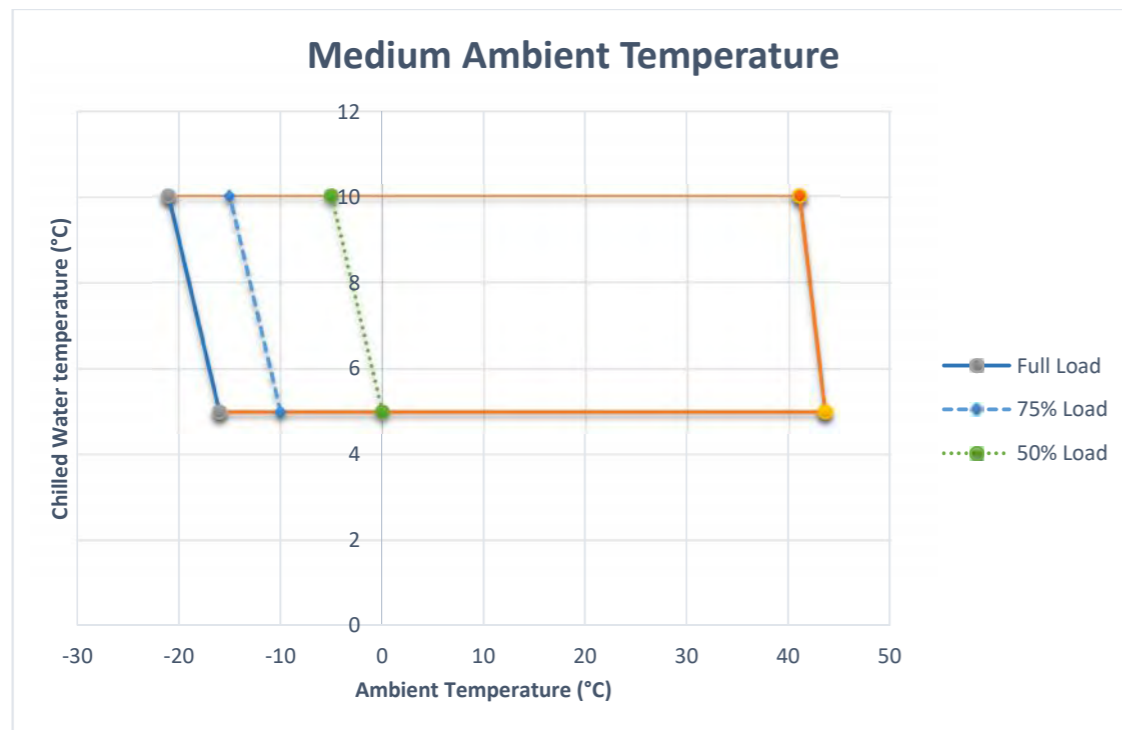

Chart B

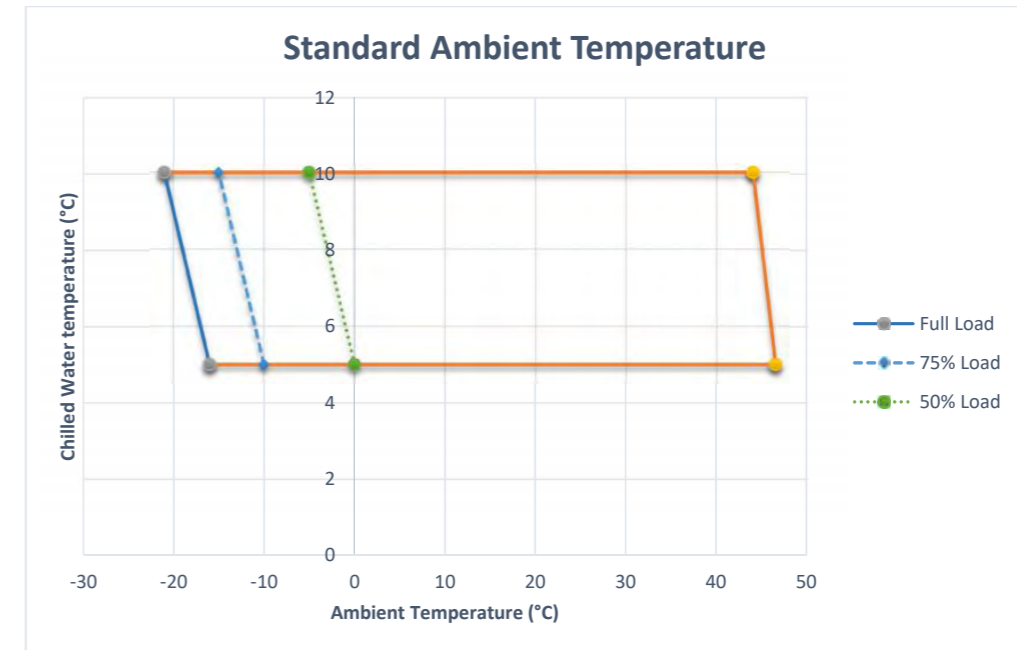
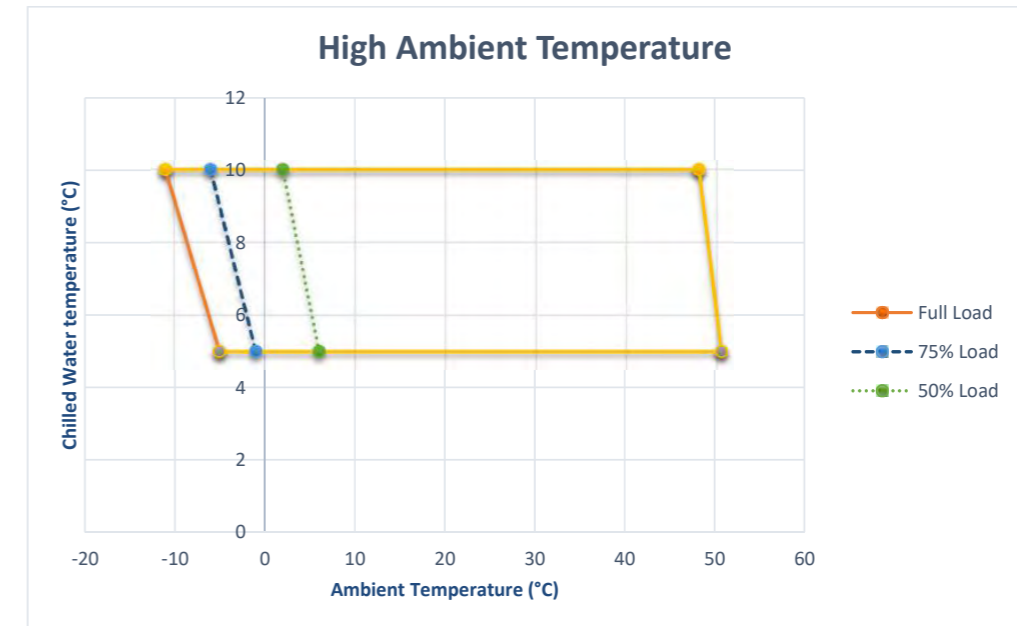

Chart C



Electrical Data

UnitModel	Rated Voltage	Compressor Quantity	Fan Quantity	Fan power (kW)	OLA (A)	FLA (A)	ICF (A)	MOP (kW)
ACW10100SSSN	400/50/3	1	2	1.94	57	74	346	44.9
ACW10110SSSN	400/50/3	1	2	1.94	64	94	419	54.9
ACW10130SSSN	400/50/3	1	2	1.94	77	106	457	68.9
ACW10150SSSN	400/50/3	1	3	1.94	87	136	497	83.8
ACW10185SSSN	400/50/3	1	3	1.94	102	156	618	93.8
ACW10215SSSN	400/50/3	1	4	1.94	116	171	691	103.8
ACW10245SSSN	400/50/3	1	4	1.94	139	198	817	117.8
ACW10280SSSN	400/50/3	1	4	1.94	156	212	959	127.8
ACW10310SSSN	400/50/3	1	5	1.94	179	234	1043	140.7
ACW20205SHSN	400/50/3	2	4	1.94	115	148	420	89.8
ACW20230SHSN	400/50/3	2	4	1.94	129	188	513	109.8
ACW20250SESN	400/50/3	2	4	1.94	157	212	563	137.8
ACW20295SESN	400/50/3	2	4	1.94	178	264	625	163.8
ACW20335SSSN	400/50/3	2	6	1.94	189	291	753	177.6
ACW20375SHSN	400/50/3	2	6	1.94	197	311	773	187.6
ACW20400SSSN	400/50/3	2	7	1.94	218	326	846	197.6
ACW20425SSSN	400/50/3	2	8	1.94	232	341	861	207.5
ACW20480SHSN	400/50/3	2	8	1.94	250	368	987	221.5
ACW20500SSSN	400/50/3	2	8	1.94	280	395	1014	235.5
ACW20565SHSN	400/50/3	2	10	1.94	313	431	1178	259.4
ACW20620SSSN	400/50/3	2	10	1.94	357	467	1276	281.4
ACW20710SHSN	400/50/3	2	12	1.94	370	541	1241	309.3
ACW20760SHSN	400/50/3	2	12	1.94	395	607	1307	333.3
ACW20830SPSN	400/50/3	2	13	1.94	418	641	1416	355.2
ACW20870SHSN	400/50/3	2	14	1.94	449	675	1450	377.2
ACW21035SPSN	400/50/3	2	16	1.94	524	702	1502	439.0
ACW21085SHSN	400/50/3	2	16	1.94	292	742	1642	457.0
ACW31510SHSN	400/50/3	3	21	1.94	797	1042	1842	652.7
ACW31540SPSN	400/50/3	3	24	1.94	784	1054	1854	658.6

1. All measures are calculated at 35 °C ambient temperature and entering/leaving water temperature 12/7 °C
2. Voltage Utilization Range: +/- 5% of rated voltage. Rated voltage (use range): 400 volt (380-420)
3. OLA - Unit Operating Load Amps
4. FLA - Unit Full load Amps
5. ICF - Instantaneous Maximum Starting amps (any point in starting sequence where sum of LRA for 'starting compressor is maximum).
6. MOP - Unit Maximum Operating Power

UnitModel	Rated Voltage	Compressor Quantity	Fan Quantity	Fan power (kW)	OLA (A)	FLA (A)	LRA (A)	MOP (kW)
ACW10100HHSN	400/50/3	1	2	1.94	56	74	346	44.9
ACW10115HHSN	400/50/3	1	2	1.94	63	94	419	54.9
ACW10135HHSN	400/50/3	1	3	1.94	77	110	461	70.8
ACW10155HHSN	400/50/3	1	3	1.94	85	136	497	83.8
ACW10190HHSN	400/50/3	1	4	1.94	99	160	622	95.8
ACW10215HHSN	400/50/3	1	4	1.94	113	171	691	103.8
ACW10255HHSN	400/50/3	1	5	1.94	137	202	821	119.7
ACW10290HHSN	400/50/3	1	6	1.94	155	219	966	131.6
ACW10325HPSN	400/50/3	1	6	1.94	172	237	1046	142.6
ACW20210HHSN	400/50/3	2	4	1.94	113	148	420	89.8
ACW20235HHSN	400/50/3	2	4	1.94	126	188	513	109.8
ACW20255HHSN	400/50/3	2	6	1.94	142	207	558	127.6
ACW20270HHSN	400/50/3	2	6	1.94	154	219	570	141.6
ACW20300HHSN	400/50/3	2	6	1.94	162	245	606	154.6
ACW20315HHSN	400/50/3	2	6	1.94	172	271	632	167.6
ACW20350HHSN	400/50/3	2	8	1.94	187	299	761	181.5
ACW20385HHSN	400/50/3	2	8	1.94	199	319	781	191.5
ACW20410HHSN	400/50/3	2	8	1.94	210	330	850	199.5
ACW20435HHSN	400/50/3	2	8	1.94	226	341	861	207.5
ACW20485HPSN	400/50/3	2	9	1.94	248	372	991	223.5
ACW20515HHSN	400/50/3	2	10	1.94	275	403	1022	239.4
ACW20575HHSN	400/50/3	2	12	1.94	310	439	1186	263.3
ACW20645HHSN	400/50/3	2	12	1.94	342	475	1284	285.3
ACW20720HPSN	400/50/3	2	13	1.94	368	545	1245	311.2
ACW20770HPSN	400/50/3	2	14	1.94	391	615	1315	337.2
ACW20845HPSN	400/50/3	2	15	1.94	414	649	1424	359.1
ACW20905HPSN	400/50/3	2	16	1.94	434	682	1457	381.0
ACW21050HPSN	400/50/3	2	18	1.94	520	710	1510	442.9
ACW21115HPSN	400/50/3	2	20	1.94	297	758	1658	464.8
ACW31250HSSN	400/50/3	3	18	1.94	724	1330	2380	799.9
ACW31455HSSN	400/50/3	3	18	1.94	813	1420	2545	874.9
ACW10100SSLN	400/50/3	1	2	1.21	56	70	342	43.4
ACW10110SSLN	400/50/3	1	2	1.21	63	90	415	53.4
ACW10125SELN	400/50/3	1	2	1.21	77	102	453	67.4
ACW10150SSLN	400/50/3	1	3	1.21	85	131	492	81.6
ACW10180MELN	400/50/3	1	3	1.21	101	151	613	91.6
ACW10210SSLN	400/50/3	1	4	1.21	114	164	684	100.8
ACW10240MSLN	400/50/3	1	4	1.21	138	191	810	114.8
ACW10270MSLN	400/50/3	1	4	1.21	157	205	952	124.8

1. All measures are calculated at 35 °C ambient temperature and entering/leaving water temperature 12/7 °C
2. Voltage Utilization Range: +/- 5% of rated voltage. Rated voltage (use range): 400 volt (380-420)
3. OLA - Unit Operating Load Amps
4. FLA - Unit Full load Amps
5. ICF - Instantaneous Maximum Starting amps (any point in starting sequence where sum of LRA for 'starting compressor is maximum).
6. MOP - Unit Maximum Operating Power

UnitModel	Rated Voltage	Compressor Quantity	Fan Quantity	Fan power (kW)	OLA (A)	FLA (A)	LRA (A)	MOP (kW)
ACW10305MELN	400/50/3	1	5	1.21	178	225	1034	137.1
ACW20200SHLN	400/50/3	2	4	1.21	112	141	413	86.8
ACW20225SSLN	400/50/3	2	4	1.21	127	181	506	106.8
ACW20245MELN	400/50/3	2	4	1.21	157	205	556	134.8
ACW20285MELN	400/50/3	2	4	1.21	180	257	618	160.8
ACW20330MSLN	400/50/3	2	6	1.21	185	281	743	173.3
ACW20365SSLN	400/50/3	2	6	1.21	196	301	763	183.3
ACW20390MSLN	400/50/3	2	7	1.21	218	326	846	197.6
ACW20420SSLN	400/50/3	2	8	1.21	227	328	848	201.7
ACW20470SHLN	400/50/3	2	8	1.21	247	355	974	215.7
ACW20485MSLN	400/50/3	2	8	1.21	278	382	1001	229.7
ACW20550SSLN	400/50/3	2	10	1.21	307	414	1161	252.1
ACW20600MELN	400/50/3	2	10	1.21	355	450	1259	274.1
ACW20695SHLN	400/50/3	2	12	1.21	365	521	1221	300.5
ACW20735SHLN	400/50/3	2	12	1.21	392	587	1287	324.5
ACW20810SHLN	400/50/3	2	13	1.21	413	619	1394	345.7
ACW20845MHLN	400/50/3	2	14	1.21	443	651	1426	366.9
ACW21010SHLN	400/50/3	2	16	1.21	519	676	1476	427.4
ACW21055MHLN	400/50/3	2	16	1.21	276	716	1616	445.4
ACW31465MSLN	400/50/3	3	21	1.21	800	1007	1807	637.4
ACW31500SHLN	400/50/3	3	24	1.21	777	1014	1814	641.0
ACW10100HHLN	400/50/3	1	2	1.21	54	70	342	43.4
ACW10110SHLN	400/50/3	1	2	1.21	62	90	415	53.4
ACW10135HHLN	400/50/3	1	3	1.21	74	105	456	68.6
ACW10150HHLN	400/50/3	1	3	1.21	83	131	492	81.6
ACW10190SHLN	400/50/3	1	4	1.21	96	153	615	92.8
ACW10215SHLN	400/50/3	1	4	1.21	111	164	684	100.8
ACW10250SHLN	400/50/3	1	5	1.21	133	193	812	116.1
ACW10285SHLN	400/50/3	1	6	1.21	150	209	956	127.3
ACW10320SHLN	400/50/3	1	6	1.21	167	227	1036	138.3
ACW20205HHLN	400/50/3	2	4	1.21	110	141	413	86.8
ACW20225SHLN	400/50/3	2	4	1.21	124	181	506	106.8
ACW20250HHLN	400/50/3	2	6	1.21	135	197	548	123.3
ACW20260HHLN	400/50/3	2	6	1.21	147	209	560	137.3
ACW20295SHLN	400/50/3	2	6	1.21	157	235	596	150.3
ACW20310SHLN	400/50/3	2	6	1.21	167	261	622	163.3
ACW20340SHLN	400/50/3	2	8	1.21	178	286	748	175.7

1. All measures are calculated at 35 °C ambient temperature and entering/leaving water temperature 12/7 °C
2. Voltage Utilization Range: +/- 5% of rated voltage. Rated voltage (use range): 400 volt (380-420)
3. OLA - Unit Operating Load Amps
4. FLA - Unit Full load Amps
5. ICF - Instantaneous Maximum Starting amps (any point in starting sequence where sum of LRA for 'starting compressor is maximum).
6. MOP - Unit Maximum Operating Power

UnitModel	Rated Voltage	Compressor Quantity	Fan Quantity	Fan power (kW)	OLA (A)	FLA (A)	LRA (A)	MOP (kW)
ACW20375SHLN	400/50/3	2	8	1.21	191	306	768	185.7
ACW20405SHLN	400/50/3	2	8	1.21	204	317	837	193.7
ACW20425SHLN	400/50/3	2	8	1.21	221	328	848	201.7
ACW20480SPLN	400/50/3	2	9	1.21	242	357	976	216.9
ACW20505SHLN	400/50/3	2	10	1.21	266	386	1005	232.1
ACW20565SHLN	400/50/3	2	12	1.21	299	419	1166	254.5
ACW20635SHLN	400/50/3	2	12	1.21	334	455	1264	276.5
ACW20705SHLN	400/50/3	2	13	1.21	359	523	1223	301.7
ACW20755SHLN	400/50/3	2	14	1.21	382	591	1291	326.9
ACW20830SPLN	400/50/3	2	15	1.21	403	623	1398	348.2
ACW20885SPLN	400/50/3	2	16	1.21	422	656	1431	369.4
ACW21030SPLN	400/50/3	2	18	1.21	509	680	1480	429.8
ACW21095SPLN	400/50/3	2	20	1.21	272	725	1625	450.2
ACW31210SELN	400/50/3	3	18	1.21	723	1300	2350	786.8
ACW31395SELN	400/50/3	3	18	1.21	824	1390	2515	861.8

1. All measures are calculated at 35 °C ambient temperature and entering/leaving water temperature 12/7 °C
2. Voltage Utilization Range: +/- 5% of rated voltage. Rated voltage (use range): 400 volt (380-420)
3. OLA - Unit Operating Load Amps
4. FLA - Unit Full load Amps
5. ICF - Instantaneous Maximum Starting amps (any point in starting sequence where sum of LRA for 'starting compressor is maximum).
6. MOP - Unit Maximum Operating Power

• Electronic control

The units are supplied with the new Pre-Configurable Controller-based electronic control and management system ensuring the following functions:

- Management of the operation of compressors:
 - Power on/off
 - 4-Steps load control (25%, 50%, 75% and 100%)
 - Unloading for high pressure or high compressor pressure ratio (integrated inside the curve of compressor operating limits this means Compressors Envelope Control)
- Chilled water temperature regulation (control on leaving water temperature (LWT) of the evaporator or on Entering water temperature (EWT) as optional).
- Control of superheating on suction line.
- Evaporator antifreeze protection.
- Management of high- and low-pressure alarms.
- Management of the compressors on over Load.
- Management of the compressors on the all circuits.
- Management of the electronic expansion valves by means of EEV controller.
- Management of external interlocks Via Dry Contacts or Modbus protocol.
- Management of the remote control:
 - Read all of sensors information
 - Alarm signals
 - Managements of all Control Parameters as LWT set point and all other control parameters
- Remote signaling, by free contacts:
 - Unit status.
 - General alarm
- Chilled or cooled water Flow switch inter lock.

The unit controller can also clearly show all control parameters of the machine on the LCD (HMI as an Option), such as:

- Display of the temperature set point at evaporator inlet or outlet.
- Display of the electronic expansion valve super heat Set Point.
- Display of each circuit discharge pressure and suction pressure.
- Display of speed control signal (percent Or Sequence) of fans.
- Display of the various alarm and operation status.
- Low/High pressure indicator.
- Low/High prevent.
- Evaporator antifreeze.
- Water flow switch signal.
- Control of the compressor operating hours.
- Compressors in operation.
- Pump in operation
- Thermal protection of compressors.
- Thermal protection of fans.
- Faulty sensors.

• Control and safety devices

Each unit is fitted with the following devices:

Safety:

- Power disconnect switch with an emergency stop function.
- Phase Control (Sequence and Range) in Electric Power
- HP switches, manual reset to be reinitialized from controller.
- Safety valve on the discharge line (HP side).
- LP switches (one for each circuit, Auto reset to be reinitialized from controller by a logical rule inside the controller and after this limit stop the compressors.
- Discharge gas temperature protection, on the discharge line of each compressor.

General

The units are to be completely factory assembled and wired in a single package complete with screw compressors, evaporator, condenser, starting control with safety and operating controls. The unit shall be given a complete factory operating and control sequence test under load conditions and shall be shipped with full operating charge of refrigerant and full oil charge.

Work Included

Provide complete electrically or micro controlled air-cooled chiller utilizing screw compressor sets suitable for outdoor installation.

Delivery and Handling

The unit shall be delivered to the job site completely assembled and charged with refrigerant and oil by the manufacturer.

Maintenance

Maintenance of the chillers shall be the responsibility of the owner and performed in accordance with the manufacturer's instructions.

Construction

The unit shall be designed for maximum corrosion protection being of heavy gauge, galvanized steel construction with baked on powder coating.

Condenser

The condenser coil shall be constructed of copper tubes and die-formed aluminum fins having self-spacing collars. Fins shall be mechanically bonded to the tubes. Integral sub-cooling circuits shall be incorporated into the coil. Condenser divider baffles shall fully separate each condenser fan section to control the airflow to maintain proper head pressure control.

Fans

The fans shall be heavy duty, aluminum blade, direct drive propeller type. Motors shall be three phase type with internal overloads. Fan blades shall be statically and dynamically balanced. Fan motor shall be rated minimum IP54 for outdoor application.

Compressor

The compressors shall be screw with suction and discharge manifold. The compressors shall be equipped with an internal crankcase heater, and oil sight glass.

Refrigerant Circuit

Compressor(s) shall be used with a direct expansion evaporator. Insulate evaporator and other cold surfaces as required to prevent condensation at ambient conditions.

Each refrigerant circuit shall include the following components:

1. Discharge line service valve.
2. High pressure switch.
3. High pressure transmitter.
4. Relief valve.
5. Liquid line service valve.
6. Refrigerant filter drier (with removable core(S)) with charging port.
7. Liquid line solenoid valve.
8. Moisture indicating sight glass.
9. Electronic expansion valve.
10. Insulation on all suction lines.
11. Suction line filter
12. Low pressure switch.
13. Low pressure transmitter.
14. Suction line service valve.

Safeties

Control box shall contain the following safeties:

1. High pressure cutout switch.
 2. Low pressure cutout switch.
 3. Circuit breakers for compressor motor overload protection and contactors (manual reset ambient insensitive type).
 4. Thermal overload on each compressor power circuit.
 5. 3-phase control on main power and optionally of each compressor power circuits.
 6. Glycerin filled gauge for demonstrating suction and discharge pressure of each circuit.
 7. Oil level safety switches for compressors to prevent compressors failure due to lubrication `s problems.
- A. Electrical Requirements:
1. Control voltage shall be 400-volt single separate power supply or manufacturer shall supply transformer package to permit 400 volts to be taken directly from unit terminal block.
 2. Unit shall be shipped with factory control and power wiring installed.

Unit Mounted Main Disconnect Switch

MCCB switch shall be furnished to isolate unit main incoming power supply for servicing.

IP54 Control Panel

Control panel with IP54 rating shall be supplied for all working environment as standard.

For the selection of a unit use the performance table and the data tables relative to each unit. For a correct chiller selection, it is also necessary:

1. Observe the functioning limits as pointed out in the chart "Operating Limits"
2. Verify that the chilled water flow is between minimum and maximum values of water flow which are tabled in the "Hydraulic Data" section; a very low flow can cause laminar flow and thus danger of ice formation and poor unit control; a very high flow can cause great pressure drops and the possibility of tube failure inside the evaporator
3. For working temperatures under 5 °C outlet water and 0 °C external air temperature it is necessary to add ethylene glycol or any other antifreeze liquids. Consult the table A.1 "SOLUTIONS OF WATER AND ETHYLENE GLYCOL" to determine the necessary quantity of ethylene glycol, the reduction of cooling capacity, the increase of power absorbed by the compressors, and the increase of evaporator pressure drop occur due to the presence of the ethylene glycol.
4. If the machine has to be installed at an altitude higher than 500 meters, you must calculate the cooling capacity reduction and the increase of power absorbed by the compressor through the coefficients pointed out in the table A.2 "CONDENSER CORRECTION FACTORS"
5. When the difference in temperature between water inlet and outlet is different from 5 °C, the cooling capacity and the absorbed power must be corrected using the table A.3 "CORRECTION FACTORS $\Delta T \neq 5$ °C".
6. If the leaving water temperature (LWT) requirement is greater than 15 C, a mixing loop is required.
7. A high cooler pressure drop can be expected when the cooler delta-T is low. A mixing loop can help to alleviate this situation.
8. A low cooler pressure drop can be expected when cooler delta-T is high.

For instance, selecting a proper unit with the following assumption will be described in 9 steps:

Assumptions:

- Actual capacity; 600 kilowatts
- Design temperature; 46 °C.
- Site altitude; 2000 m.
- Maximum ambient working temperature ;50 °C
- Minimum ambient temperature -5.
- Inlet and outlet evaporator brine temperatures are 12°C and 7°C.

Step 1:

Extract Kc_1 , Kp_1 , Kdp_1 and $KFWE_1$ from table A.1 in Appendix.

In this case the freezing temperature must be lower than -5°C, so with adding 20% Ethylene Glycol by weight to Water the freezing point will be -8.7°C and refer to table A.1, $Kc_1=0.99$, $Kp_1=0.99$, $Kdp_1=1.05$ and $KFWE_1=1.06$.

Step 2:

Altitude of site is 2000 m. Refer to table A.2; Kc_2 and Kp_2 will be 0.98 and 1.04 in respect.

Step 3:

Since $\Delta T=12-7=5$; Kc_3 and Kp_3 from table A.3 "CORRECTION FACTORS $\Delta T \neq 5$ °C" are equal to 1.

Step 4:

According to the following equations calculate unit capacity and unit absorbed power in standard condition.

$$Q_{Actual} = Kc_1 * Kc_2 * kc_3 * Q_{Standard} \quad (\text{Equation 1})$$

$$P_{Actual} = Kp_1 * Kp_2 * kp_3 * P_{Standard} \quad (\text{Equation 2})$$

$$600 = 0.99 * 0.98 * 1 * Q_{Standard} \quad \text{then } Q_{Standard} = 600 / 0.97; \quad Q_{Standard} = 619 \text{ kW.}$$

Acceptable deviation from capacity is 5%, so required unit has to be between 590 kW and 650 kW (590 kW < unit capacity < 650 kW).

Step 5:

Ambient temperature in actual full load is 46°C, so refer to "Performance Data" tables to select proper model.

Step 6:

Since the maximum ambient temperature of operating is 50 °C; select a model from "High Ambient temperature" types.

Refer to "Performance Data" table, ACW20720HPSN unit capacity is 622 kW. So, the actual capacity is $Q_{Actual} = Kc_1 * Kc_2 * kc_3 * Q_{Standard} = 0.99 * 0.98 * 1 * 622$

$$Q_{Actual} = 603.5 \text{ kw}$$

Step 7:

Unit total absorbed power is 260.4 kW. Calculate new absorbed power from Equation 2.

$$P_{Actual} = 0.99 * 1.04 * 1 * 260.4 \text{ so } P_{Actual} = 268.1 \text{ kW}$$

Step 8:

Standard model Water Flow Rate will be calculated by Equation 3.

New Water Flow Rate = $KFWE_1 * \text{Standard Water Flow Rate}$ (Equation 3)

Refer to "Performance Data" table find "Standard Water Flow Rate" which equals to 106.6 (m³/hr.)

$$\text{New Water Flow Rate} = 1.06 * 106.6 = 112 \text{ (m}^3\text{/hr.)}$$

Step 9:

For Calculating Cooler Pressure drop, use Equation 4.

New Pressure Drop = $Kdp_1 * \text{Standard Pressure Drop}$ (use performance data table.)

$$\text{New Pressure Drop} = 1.05 * 43 = 45.15 \text{ kPa.}$$

Table A.1 SOLUTIONS OF WATER AND ETHYLENE GLYCOL

SOLUTIONS OF WATER AND ETHYLENE GLYCOL		% Ethylene Glycol by Weight					
		0	10	20	30	40	50
Freezing Tempere	(°C)	0	-3.7	-8.7	-15.3	-23.5	-35.6
Cooling Capacity Correction Factor	Kc1	1	0.99	0.99	0.98	0.97	0.96
Absorbed Power Correction Factor	kp1	1	1	0.99	0.99	0.98	0.98
Pressure Drop Correction Factor	Kdp1	1	1.02	1.05	1.07	1.1	1.13
Water Flow Correction Factor	K _{FWE1}	1	1.03	1.06	1.09	1.12	1.15

Table A.2 CONDENSER CORRECTION FACTORS

Condenser Correction Factor		Altitude (m)					
		0	500	1000	1500	2000	2500
Cooling Capacity Correction Factor	Kc2	1	0.99	0.99	0.98	0.98	0.97
Absorbed Power Correction Factor	Kp2	1	1.01	1.02	1.03	1.04	1.05

Table A.3 CORRECTION FACTORS $\Delta T \neq 5^\circ\text{C}$

Correction factor $\Delta T \neq 5^\circ\text{C}$		ΔT						
		4	5	6	7	8	9	10
Cooling Capacity Correction Factor	Kc3	0.99	1	1.01	1.02	1.02	1.03	1.04
Absorbed Power Correction Factor	Kp3	1	1	1	1.01	1.01	1.02	1.02

Table A.4 CORRECTION FACTORS FOR AMBIENT TEMPERATURE

Correction factor For Ambient Temperature		Ambient Temperature									
		15	20	25	30	35	40	43	46	50	52
Cooling Capacity Correction Factor	Kc4	1.21	1.17	1.11	1.06	1.00	0.94	0.90	0.86	0.81	0.79
Absorbed Power Correction Factor	Kp4	0.73	0.79	0.85	0.92	1.00	1.09	1.15	1.22	1.31	1.36

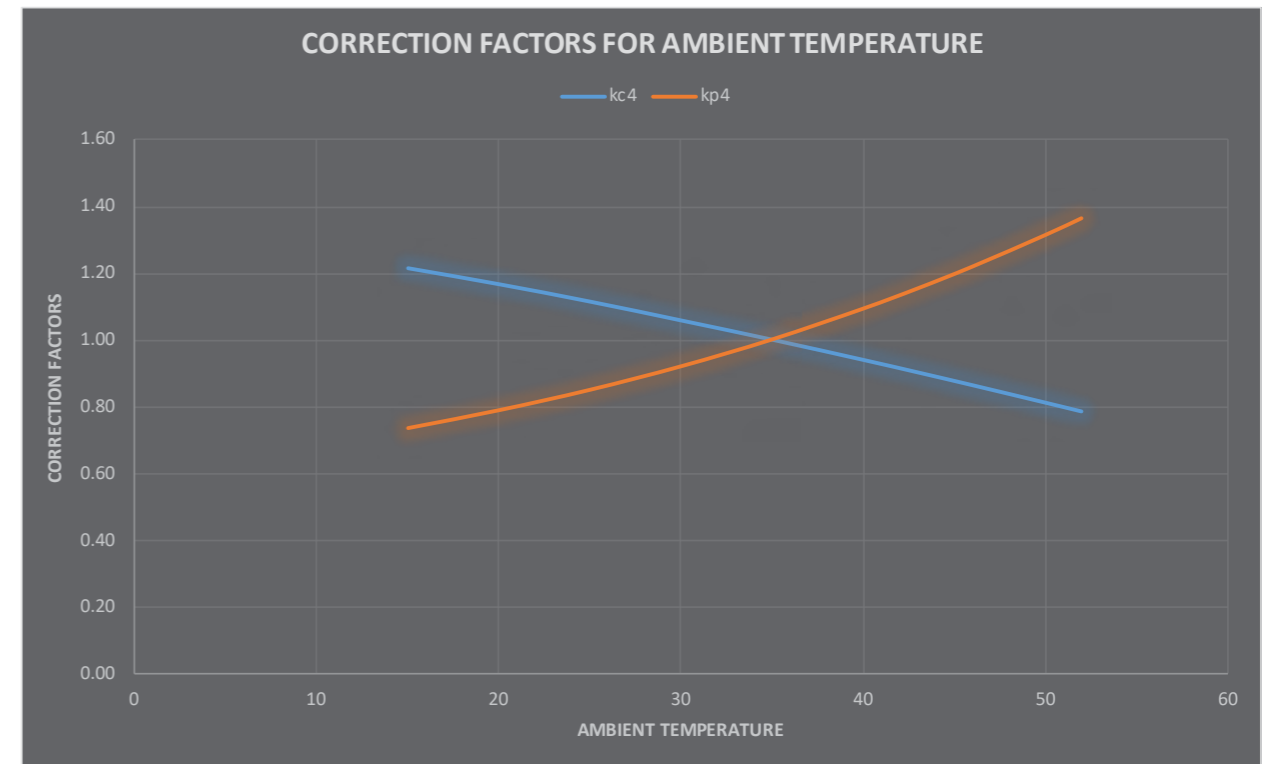

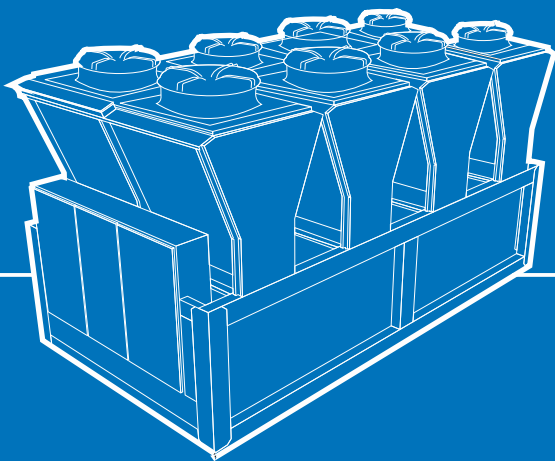

ARVAND



www.arvandcorp.com

“ARVAND Co. reserves the right to revise and make changes in design and construction of any product at any time without notice.”